

# Drilling Blowout Prevention Systems

## Class IV

(For Wells not exceeding a depth of 6100m)

(Minimum Pressure Rating 34,000 kPa)

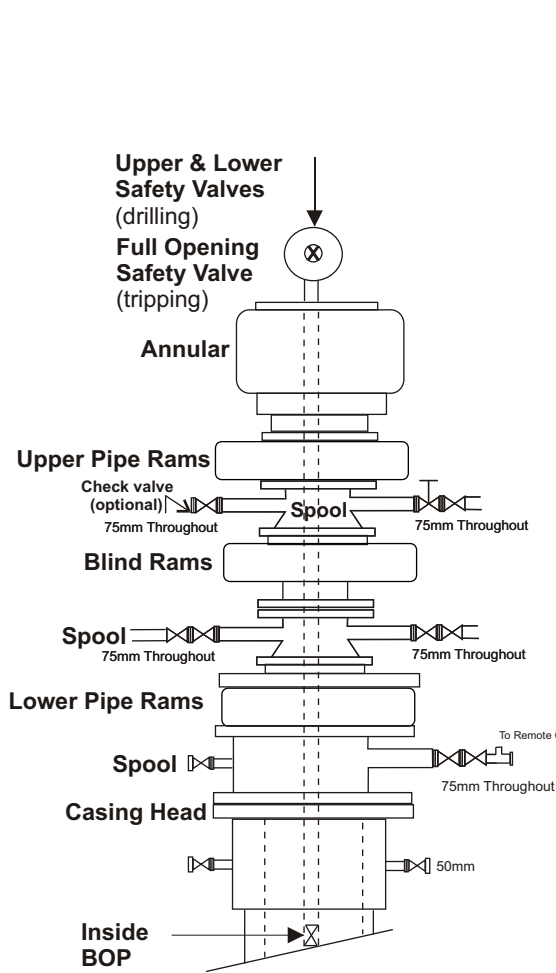

**BLOWOUT PREVENTION STACK**

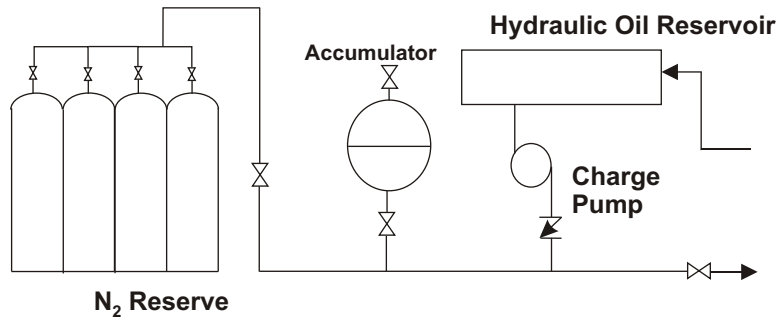

**ACCUMULATOR SYSTEM**

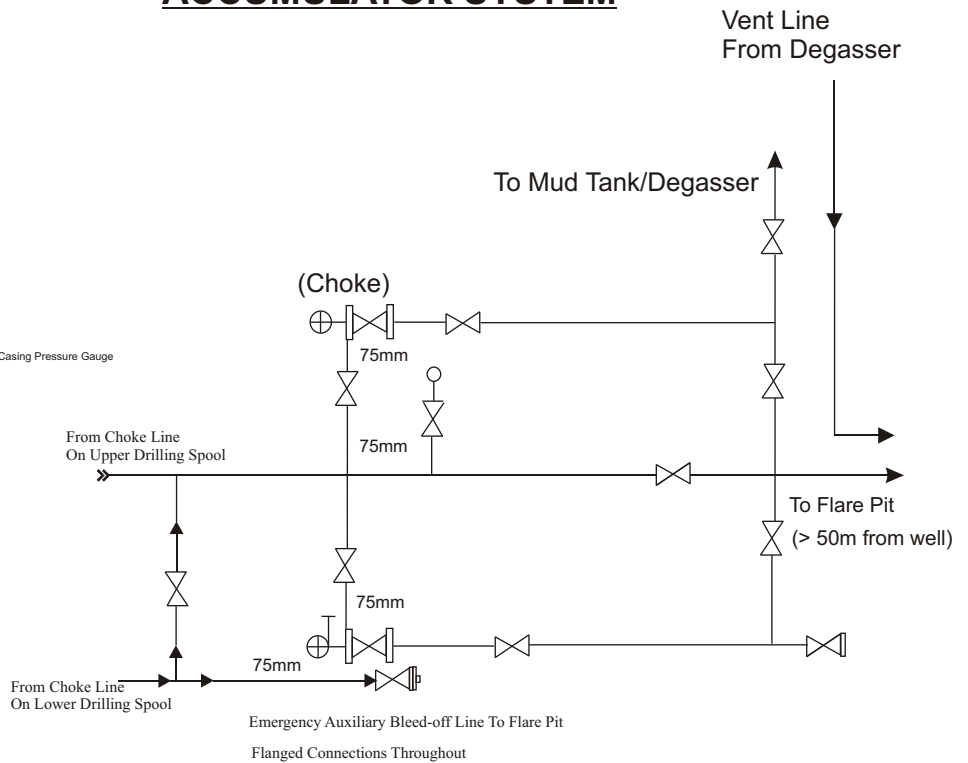

**MANIFOLD SYSTEM**

**Note:**

1. Kill and bleed-off systems 75mm minimum nominal diameter throughout.
2. Flanged pipe connections from the drilling spool to the last valve on the manifold, inclusive.
3. The upper pipe rams and blind rams can be a double ram combination.
4. Hydraulic and manual valve positions on bleed-off lines are interchangeable.
5. Location of blind ram and pipe ram at operator's discretion.