

Drilling Blowout Prevention Systems

Class V

(For Wells not exceeding a depth of 12,500m)

(Minimum Pressure Rating 69,000 kPa)

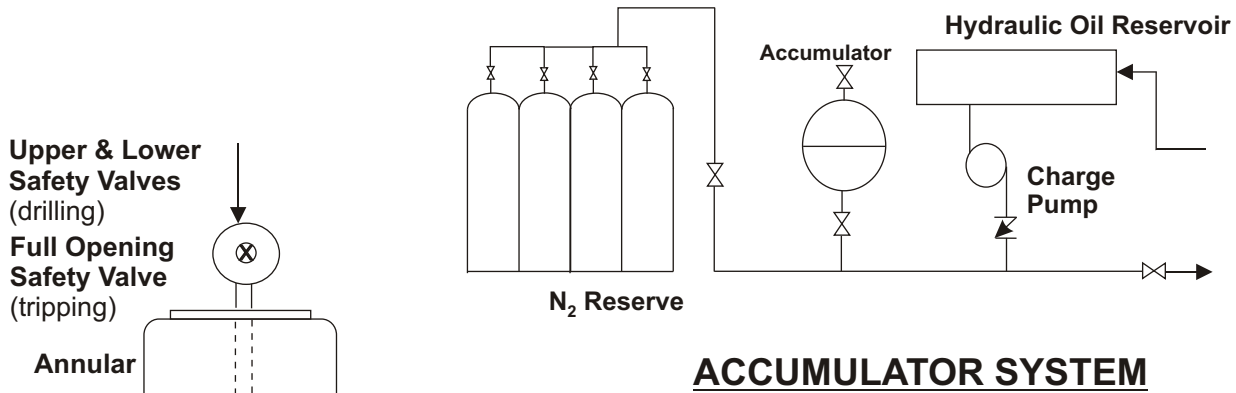

ACCUMULATOR SYSTEM

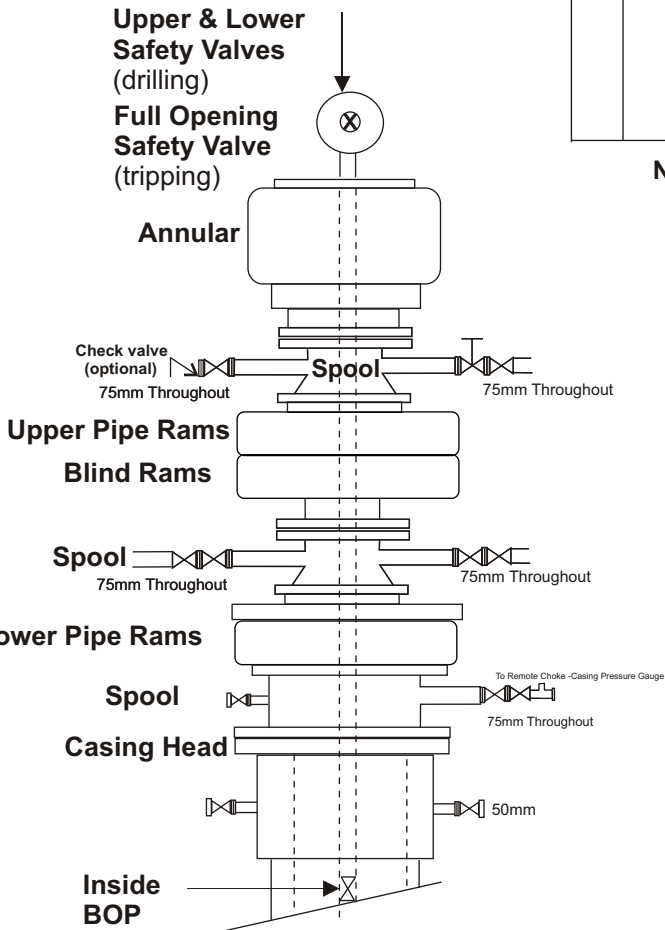

BLOWOUT PREVENTION STACK

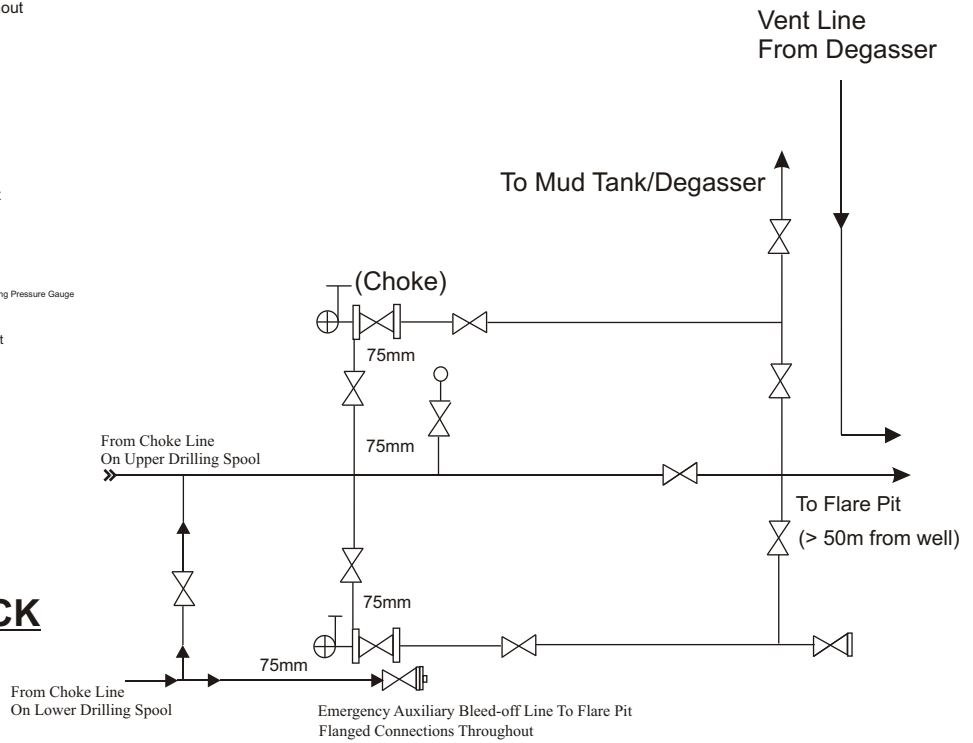

MANIFOLD SYSTEM

Note:

1. Kill and bleed-off systems 75mm minimum nominal diameter throughout.
2. Flanged pipe connections from the drilling spool to the last valve on the manifold, inclusive.
3. Hydraulic and manual valve positions on bleed-off lines are interchangeable.