

PERIODIC COMMERCIAL MOTOR VEHICLE INSPECTIONS – *TRAILER*

UPDATED OCTOBER 2014



NOTICE TO USERS

General requirements and policy / application issues related to NSC 11B on PMVI can be found in the general introduction of the PMVI Consolidated Standard, ISBN 978-1-927993-02-6, posted on the CCMTA web site @ <http://ccmta.ca/en/home/item/national-safety-code-standard-11-update-2014>.

Contents

Introduction	1
Instructions for Technician-Inspector Conducting Inspections	1
Workplace Safety.....	1
Inspection Outcome Based on Current Vehicle Condition	1
Inspection Methods	1
Informational Notes	1
Definitions.....	1
Categorization of Fluid (Liquid) Leaks	3
Illustrations and Diagrams used in the Standards.....	3
Measurements and Tolerances.....	3
Pressure.....	4
Mass (weight)	4
Distance.....	4
Identification of Defective Conditions of the Types of Hose, Tubing and Lines used on Vehicles	5
Section 1 – Power Train	6
1. Accelerator Pedal/Throttle Actuator.....	6
2. Exhaust System	6
3. Emission Control Systems and Devices.....	7
4. Drive Shaft.....	7
5. Clutch and Clutch Pedal.....	7
6. Engine/Transmission Mount.....	7
7. Engine Shut Down	8
8. Engine Start Safety Feature	8
9. Gear Position Indicator	8
10. Engine or Accessory Drive Belt	8
11. Hybrid Electric Vehicle & Electric Vehicle Power Train System	8
12. Gasoline or Diesel Fuel System	8
13. Pressurized or Liquefied Fuel System (LPG, CNG and LNG)	9
Section 2 – Suspension	12
1. Suspension & Frame Attachments	12
2. Axle Attaching & Tracking Components.....	12
3. Axle & Axle Assembly	14
4. Spring & Spring Attachment	14
5. Air Suspension	15
6. Self-Steer and Controlled-Steer Axle	17
7. Shock Absorber/Strut Assembly.....	17

Section 3 – Brake Systems	18
A. OPTIONS FOR INSPECTING INTERNAL BRAKE COMPONENTS OF HYDRAULIC AND AIR BRAKE SYSTEMS.....	18
1. Types of Brake Inspections.....	18
2. Disassembly of Wheels and/or Drums for Inspection	19
3. Exemptions from Brake Disassembly for Drum Brakes	19
4. Exemptions from Wheel Disassembly for Disc Brakes.....	19
5. Exemptions from Brake/Wheel Disassembly for New Vehicles.....	19
6. Summary of Inspection Requirements for Trucks and Trailers on 12-Month Inspection Cycle.....	20
7. Summary of Inspection Requirements for Trucks on 6-Month Inspection Cycle.....	20
8. Summary of Inspection Requirements for Buses.....	21
B. REQUIRED MEASUREMENT OF BRAKE COMPONENTS.....	22
1. Drum Brake Systems	22
2. Disc Brake Systems.....	22
C. DOCUMENTS REQUIRED FOR QUALIFYING A PRIOR INSPECTION OF INTERNAL BRAKE COMPONENTS.....	22
1. Common Information.....	22
2. Additional Information Required for Drum Brakes.....	22
3. Additional Information Required for Disc Brakes.....	23
D. PROHIBITION ON REMOVAL OF BRAKES FROM A VEHICLE	23
Section 3H – Hydraulic Brakes	24
1. Hydraulic System Components	24
2. Brake Pedal/Actuator	25
3. Vacuum Assist (Boost) System on Truck or Bus.....	25
4. Hydraulic Assist (Boost) System on Truck or Bus.....	25
5. Air Assist (Boost) System on Truck or Bus.....	25
6. Air-Over-Hydraulic Brake System.....	25
7. Surge Brake Controller on Trailer.....	26
8. Vacuum System on Trailer	27
9. Air-Boosted Trailer Brake System	27
10. Electric Brake System on Trailer.....	27
11. Brake System Indicator Lamps.....	28
12. Drum Brake System Components	28
13. Disc Brake System Components	31
14. Mechanical Parking Brake.....	33
15. Spring-Applied Air-Released (SAAR) Parking Brake	33
16. Spring-Applied Hydraulic-Released (SAHR) Parking Brake.....	33
17. Anti-Lock Brake System (ABS) on a Truck or Bus.....	33
18. Stability Control System	33
19. Brake Performance	34

Section 3A – Air Brakes	35
1. Air Compressor.....	35
2. Air Supply System.....	35
3. Air System Leakage on a Trailer.....	35
4. Air Tank.....	36
5. Air Tank Check Valves.....	36
6. Brake Pedal/Actuator.....	37
7. Treadle Valve and Trailer Hand Valve.....	37
8. Brake Valves & Controls.....	37
9. Proportioning, Inversion or Modulating Valve.....	37
10. Towing Vehicle (Tractor) Protection System.....	37
11. Parking Brake and Emergency Application on Truck or Bus.....	37
12. Parking Brake and Emergency Application on Trailer.....	38
13. Air System Components.....	38
14. Brake Chamber.....	39
15. Drum Brake System Components.....	40
16. S-Cam Drum Brake System.....	43
17. Brake Shoe Travel (Wedge Brakes).....	45
18. Disc Brake System Components.....	46
19. Anti-Lock Brake System (ABS) on Truck and Bus.....	48
20. Anti-Lock Brake System (ABS) on Trailer.....	48
21. Stability Control System on Truck or Bus.....	50
22. Stability Control System (Electronic Stability Control [ESC] or Roll Stability System [RSS]) on Trailer.....	50
23. Brake Performance.....	50
Section 4 - Steering	52
1. Steering Control and Linkage.....	52
2. Power Steering System (Hydraulic and Electric).....	53
3. Steering Operation (Active Steer Axle).....	53
4. Kingpin.....	53
5. Self-Steer and Controlled-Steer Axle.....	54
Section 5 - Instruments & Auxiliary Equipment	56
1. Fire Extinguisher.....	56
2. Hazard Warning Kit.....	56
3. Horn.....	56
4. Instruments and Gauges on a Bus.....	56
5. Speedometer.....	56
6. Odometer.....	56
7. Windshield Wiper/Washer.....	56
8. Heater & Windshield Defroster.....	56

9. Fuel-burning Auxiliary Heater	56
10. Chain/“Headache” Rack	56
11. Auxiliary Controls and Devices	56
12. Auxiliary Drive Controls	56
13. On-board Auxiliary Equipment on a Bus.....	56
14. First Aid Kit on a Bus.....	56
15. Accessibility Features and Equipment on a Bus	56
Section 6 – Lamps	57
1. Required Lamps.....	57
2. Reflex Reflector.....	60
3. Retro-Reflective Marking.....	61
4. Instrument Panel Lamp.....	61
5. Headlamp Aim	61
6. Interior Lamps on a Bus.....	61
7. School Bus Additional Lamps	61
Section 7 – Electrical System	65
1. Wiring.....	65
2. Battery	65
3. Trailer Cord (output to towed vehicle)	66
4. Alternator Output on a School Bus	66
Section 8 – Body.....	67
1. Hood or Engine Enclosure.....	67
2. Tilt Cab	67
3. Air-Suspended Cab	67
4. Cab and Passenger-Vehicle Body.....	67
5. Cargo Body.....	67
6. Frame, Rails & Mounts.....	69
7. Unitized Body Elements.....	71
8. Cab or Cargo Door.....	71
9. Cargo Tank or Vessel.....	72
10. Body, Device or Equipment Attached or Mounted to the Vehicle.....	73
11. Refrigeration/Heater Unit Fuel System (Reefer or Auxiliary Power Unit [APU])	74
12. Bumper.....	74
13. Windshield.....	74
14. Side Windows.....	74
15. Rear Window.....	74
16. Interior Sun Visor	74
17. Exterior Windshield Sun Visor.....	74
18. Rear-view Mirror	74
19. Seat.....	74

20. Seat Belt/Occupant Restraint.....	74
21. Fender/Mud Flap.....	75
22. Landing Gear on Trailer.....	76
23. Sliding Axle Assembly (Sliding Bogie) on Trailer.....	76
24. Aerodynamic Device and Attachment.....	77
25. Rear Impact Guard (RIG) on Trailer.....	78
26. Floor Pan/Baggage Floor/Step Well on a Bus.....	80
27. Interior Body and Fixtures on a Bus.....	80
28. Service and Exit Door on a Bus.....	80
29. Emergency Exit (Door, Window and Roof Hatch) on a Bus.....	80
30. Passenger Compartment Window on a Bus (Except Emergency Exit Window).....	80
31. School Bus Exterior Mirror (Except Standard Left and Right Side Mirror).....	80
32. Passenger Seat on a Bus.....	80
33. School Bus Body Exterior.....	80
34. Auxiliary Compartment on a Bus.....	80
Section 9 – Tire and Wheel.....	81
1. Tire Tread Depth.....	81
2. Tire Tread Condition.....	81
3. Tire Sidewall and Manufacturer Markings.....	82
4. Tire Inflation Pressure.....	83
5. Wheel Hub.....	84
6. Wheel Bearing.....	85
7. Wheel/Rim (Applies to all wheel types).....	86
8. Multi-Piece Wheel/Rim.....	87
9. Spoke Wheel/Demountable Rim System.....	87
10. Disc Wheel System.....	88
11. Wheel Fasteners (Nuts, Bolts and Studs).....	88
Section 10 – Coupling Devices.....	89
1. Hitch Assembly, Structure and Attaching Components.....	89
2. Secondary Attachment (Safety Chain or Cable).....	90
3. Pintle Hook, Pin Hitch, or Coupler Hitch.....	90
4. Ball Type Hitch.....	91
5. Roll-Coupling Hitch.....	91
6. Automated Coupling Device.....	92
7. Fifth Wheel Coupler.....	92
8. Oscillating Fifth Wheel Coupler.....	95
9. Ball-Bearing Type Turntable on Trailer.....	96
Appendix A.....	97
1. Liquefied Petroleum Gas (LPG or Propane) Fuel System.....	97
2. Compressed Natural Gas (CNG) Fuel System.....	100
3. Liquefied Natural Gas (LNG) Fuel System.....	102

Introduction

Instructions for Technician-Inspector Conducting Inspections

Workplace Safety

Some of the inspection procedures described in this standard require the use of tools and equipment, and may involve safety hazards. It is assumed that the individual performing inspections according to this standard is fully familiar with all relevant workplace safety requirements and protocols.

No specific safety warnings are provided within this document. All relevant and appropriate safety precautions are the responsibility of the inspector/mechanic/technician and the workplace where the inspection is conducted.

Inspection Outcome Based on Current Vehicle Condition

A vehicle is to be inspected and determinations made about the pass or fail outcome of the inspection based on the condition of the vehicle at the time of inspection. The inspection is not intended to ensure that a vehicle remains in a safe condition for any particular period after the inspection.

Inspection Methods

The inspection of vehicle components and systems conducted to determine compliance with this standard consists mainly of visual inspection activities.

An inspection will also involve testing, removal and/or disassembly of components, measurements and other actions in certain cases. Whenever inspection of an item requires more than a visual inspection, additional inspection procedures are specifically provided for each item. These are displayed with the heading “*Additional Inspection Procedure(s):*” “*Optional Additional Inspection Procedure(s)*” or “*Optional Inspection Procedure(s)*”, appearing before the text describing the necessary steps.

The items that require inspection on any particular vehicle are based on the specific components and systems that were required by any applicable regulations, (e.g.: CMVSS or Provincial/Territorial legislation/regulation) applicable to the vehicle at the time it was manufactured, are ordinarily present on a vehicle; were present on a vehicle when that vehicle was manufactured, or are required for normal and safe vehicle operation. This standard is not meant to be used to identify all of the components or systems that are present on that vehicle.

Informational Notes

In many cases additional information is provided to clarify the inspection procedure or assist in consistent interpretation of the standard. These are displayed with the heading “*Note:*” appearing before the text.

Definitions

Various terms and acronyms are used throughout this standard. These terms have specific and consistent meanings as they relate to conducting periodic inspections, and identifying defective conditions. The purpose of defining these terms is to support consistent interpretation and application of the language used in this standard. The terms that are defined below are highlighted whenever they appear in each section to remind the reader that the condition is one of those that is specifically defined. This reminder also appears in the footer of each page of this document.

The meaning of each of the terms, for the purposes of conducting inspections according to this standard, is as follows:

“**abnormally worn**” – means unusual, excessive or exceptional wear of a vehicle component, indicative of the presence of some deterioration or defect in that component, or in a related part of a vehicle. This term is used selectively in this standard for a component or system where some wear is normal, and does not directly have any effect on vehicle safety. It is expected that the inspector knows the amount of wear, and the type of wear, that is typical (normal) based on the age and operation of a vehicle.

“**ANSI**” – means the American National Standards Institute, and standards developed by ANSI which have been adopted in jurisdictional equipment regulations.

“applicable requirements” – means the applicable requirements of the relevant jurisdiction, (i.e.: province or territory). This phrase is used in situations where one or more provinces, or territories, have a different standard, requirement or criteria. It is expected that the inspecting technician will know what the requirements are in the jurisdiction where they perform inspections.

“CMVSS” – means the Canadian Motor Vehicle Safety Standards (CMVSS) and their supporting Technical Standards Documents. These are Canadian manufacturing standards for vehicles which are developed and updated by Transport Canada and which are referenced in jurisdictional equipment regulations.

“CSA” – means the Canadian Standards Association, an association that develops standards that apply to vehicles, (i.e.: CSA B51, B109, B620, D250, D409, D435, D436 etc.). These standards are updated on a periodic basis and are often referenced in jurisdictional equipment regulations.

“CVSA” – means the Commercial Vehicle Safety Alliance, a voluntary organization comprised primarily of on-road enforcement officers from Canada, United States and Mexico. The CVSA administers the North American Standard Out-of-Service Criteria (OOSC) that are similar, but not identical, to the Hazardous Conditions defined in this standard. The basis for any differences in these conditions stems from the fact that the OOSC apply at a road side inspection while the Hazardous Conditions apply in a shop setting.

“damaged” – means any unintended condition, or condition caused by means other than normal use, that is likely to impair normal function.

“FMVSS” – means Federal Motor Vehicle Safety Standards. These are U.S. manufacturing standards for vehicles which are developed and updated by the National Highway Traffic Safety Administration of the Department of Transport.

“Hazardous Condition” – means a condition that is so dangerous or unsafe that it requires corrective action before the vehicle can return to service and be permitted to operate. A vehicle with a hazardous condition is considered too unsafe to be driven and in some jurisdictions driving a vehicle with a hazardous condition is prohibited. (*Note:* In most cases driving a vehicle with a condition that causes it to fail an inspection is a violation. Driving a vehicle with a hazardous condition is an additional and more serious offence.)

“industry standard” – means installation, modification or repair methods described in industry-accepted recommended practices published by the Society of Automotive Engineers (SAE), recommended practices published in the Technology and Maintenance Council (TMC) of the American Trucking Associations, standards developed and published by Canadian Standards Association (CSA), and other similar documents from similar organizations.

“inoperative” – means a vehicle component or system does not operate the way: it ordinarily operates; it operated when the vehicle was manufactured, or it is required to operate for normal and safe vehicle operation.

“insecure” – means that an item is beginning to become detached due to deterioration of the means of mounting. This can also mean that a method of attachment has been used that is in itself unsafe by being unable to withstand normal vehicle operation, or is not at least equivalent to the OEM standard method of attachment.

“loose” - means that an item is detached, or no longer fully attached, due to failure or deterioration of one or more means of attachment.

“missing” – means that an item is absent (such as ‘removed’ or ‘detached’) that: is ordinarily present on the vehicle; was present on the vehicle when the vehicle was manufactured, or is required for normal and safe vehicle operation.

“manufacturer” – means the manufacturer of the vehicle, the manufacturer of a major vehicle component or system, or manufacturer of aftermarket parts that are direct replacements for OEM parts. Examples of major components or systems include, but are not limited to: engines, transmissions, axles, brake systems, steering systems, suspension systems, etc.

“OEM” – means ‘original equipment manufacturer’ and refers to the ‘brand name’ manufacturer of the vehicle.

“OEM standard” – means the manufacturing methods, component or assembly quality, and performance level, set by the manufacturer of a vehicle, or vehicle component, to ensure a vehicle is able to safely perform at its intended level, and to ensure the vehicle complies with the relevant CMVSS (or FMVSS) requirements. It includes component quality, performance levels, repair methods, durability, safety, and the service methods outlined in the warranty and service literature provided for the use and maintenance of a vehicle. Parts supplied by OEM, and established aftermarket manufacturers of parts intended for direct replacement of OEM parts, are generally considered to meet OEM standard.

“operate as intended” – means the manner in which a vehicle component or system ordinarily operates; it operated when the vehicle was manufactured, or is required to operate for normal and safe vehicle operation.

“reject if” – means a condition if present at time of inspection, or if present after repairs, results in a failed inspection.

“rust jacking” – means a build up of rust that results in lifting, separation or bulging of components originally designed to remain in contact with each other, (i.e.: brake linings, suspension, frame and body components).

“SAE” – means the Society of Automotive Engineers.

Categorization of Fluid (Liquid) Leaks

Every reference to a fluid (or liquid) leak listed as a reject condition is categorized with respect to the level of severity of the leak. The level of severity is categorized as either level 1, level 2, or level 3, and each category is defined below. A vehicle with a leak that meets the defined level, or leaking more severely than this level, will cause the vehicle to fail inspection.

“level 1 leak” – means seepage of fluid that is not great enough to form drops

“level 2 leak” – means seepage of fluid that is great enough to form drops, but not great enough to cause the drops to fall during inspection

“level 3 leak” – means seepage of fluid that forms drops and those drops fall during inspection

Illustrations and Diagrams used in the Standards

In an effort to improve the consistency and uniformity of the inspection process a series of diagrams and illustrations are used in this version of the standard. When a diagram or illustration is in conflict with a legislated or regulatory requirement the latter prevails.

Measurements and Tolerances

Many of the inspection items and reject conditions involve measurements of mass or weight, pressure and distance. To achieve consistent application of each criterion that involves such a measurement, it is necessary to address the degree of precision associated with such measurements. In determining the appropriate level of precision or tolerance, it is also necessary to consider the measuring tools that will be commonly used to make each of these measurements.

The level of precision associated with any measurement is defined by the tolerance stipulated for that measurement. Tolerance is expressed as a plus or minus (+/-) value. The actual window of precision is double the value of the tolerance. For example 20 kg with a tolerance of +/- 0.5 kg, means that the precision of the measurement is to the nearest 1 kg. Similarly, 50 mm (+/- 1 mm), means a value of 49 to 51 mm. The measurement tolerance of 1 mm renders a measurement precision of within 2 mm.

Given the similarities in the measurements that appear most frequently in this standard, standard tolerances are given for most of these measurements. The standard tolerances that are listed below apply in all cases where no additional tolerance is provided. In cases where the standard tolerance does not apply, the tolerance for that criterion is provided adjacent to the measurement. Whenever a tolerance is provided adjacent to a measurement, the tolerance stipulated with the measurement is to be used in place of the standard tolerance listed below.

Measurements of distance are the most common in this standard and also have a significant variance in terms of the range of distance that is used. Four different standard tolerance values are used for distance.

Pressure

Metric ("SI" or "International System of Units") pressure value = *kilopascals (kPa)*,

Imperial (American) pressure value = *pounds per square inch or pounds/inch² (psi)*

Conversion Factors: $1\text{ kPa} = 0.145\text{ psi}$, $6.9\text{ kPa} = 1\text{ psi}$

Standard tolerance for all pressure values: $\pm 5\text{ kPa}$ (0.5 psi)

Mass (weight)

Metric (SI) mass value: *kilogram (kg)*

Imperial (American) mass value: *pound (lb.)*

Conversion Factors: $1\text{ kg} = 2.2\text{ lb.}$, $0.454\text{ kg} = 1\text{ lb.}$

Standard tolerance for all mass (weight) values: $\pm 0.5\text{ kg}$ (1 lb.)

Distance

Metric (SI) distance value: *millimetre (mm)*

Imperial (American) distance value: *inch (in.)*

Conversion Factors: $1\text{ mm} = 0.039\text{ in.}$, $1\text{ in.} = 25.4\text{ mm}$







Standard tolerance for distance value ranges

Tolerances for distance measurements vary based on the type and precision of the criterion as follows:

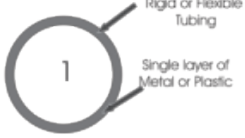
1. **Large distance measurements of greater than 25 mm:** tolerance is $\pm 5\text{ mm}$
(accuracy is to the nearest 10 mm)
2. **Short distance measurements of 1 to 25 mm, where the distance value is expressed as a whole mm:**
tolerance is $\pm 0.5\text{ mm}$ (accuracy is to the nearest 1 mm)
3. **Precise short distance measurements of 1.0 to 25.0 mm, where the distance value is expressed as one-tenth of a mm:** tolerance is $\pm 0.05\text{ mm}$ (accuracy is to the nearest 0.1 mm)
4. **Micro distance measurements of less than 1 mm:** tolerance is $\pm 0.005\text{ mm}$
(accuracy is to the nearest 0.01 mm)
5. For the purpose of these tolerances, the following equivalent values are used:

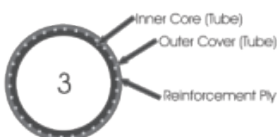
Comparable Measurement Tolerances	
Tolerance in metric measurements	Tolerance in Imperial measurements
$\pm 5\text{ mm}$	± 0.125 (1/8) in.
$\pm 0.5\text{ mm}$	± 0.02 in.
$\pm 0.05\text{ mm}$	± 0.002 in.
$\pm 0.005\text{ mm}$	± 0.0005 in.

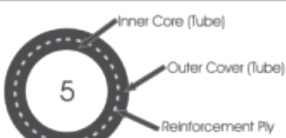
Identification of Defective Conditions of the Types of Hose, Tubing and Lines used on Vehicles

	Characteristics	Defective Condition
 <p>1</p> <p>Rigid or Flexible Tubing</p> <p>Single layer of Metal or Plastic</p>	<p>Type 1 – Copper, Steel or plastic tubing used for liquid or vapour.</p> <p>Made of a single layer of material.</p>	<p>Damage is visible on the outside that is reducing the wall thickness.</p>
 <p>2</p> <p>Inner Core (Tube)</p> <p>Outer Cover (Tube)</p>	<p>Type 2 – Plastic (usually Nylon) tubing commonly used in air brake systems. <u>No reinforcement ply</u>. Inner core and outer cover are usually different color.</p>	<p>Inner core becomes visible from the outside, as shown by color change.</p>
 <p>3</p> <p>Inner Core (Tube)</p> <p>Outer Cover (Tube)</p> <p>Reinforcement Ply</p>	<p>Type 3 – Plastic (usually Nylon) tubing commonly used in air brake systems. <u>With reinforcement ply</u>. Inner and outer core are different color.</p> <p>(Note: Type 2 and 3 may appear identical externally.)</p>	<p>Reinforcement ply or inner core is visible from the outside, as shown by color change.</p>
 <p>4</p> <p>Inner Core (Tube)</p> <p>Outer Protective & Reinforcement Ply</p>	<p>Type 4 – Stainless steel outer cover with inner layer of tubing.</p>	<p>Damage through the outer cover.</p>
 <p>5</p> <p>Inner Core (Tube)</p> <p>Outer Cover (Tube)</p> <p>Reinforcement Ply</p>	<p>Type 5 – Synthetic rubber hose with inner reinforcement ply.</p>	<p>Wear or damage exposing the reinforcement ply.</p>
 <p>6</p> <p>Inner Core (Tube)</p> <p>Outer Cover (Tube)</p> <p>Reinforcement Plies</p>	<p>Type 6 – Synthetic rubber hose with multiple reinforcement plies.</p>	<p>Wear or damage exposing the outer reinforcement ply.</p>
 <p>7</p> <p>Inner Core (Tube)</p> <p>Outer Cover (Tube)</p> <p>Reinforcement Ply</p> <p>Outer Protective Material</p>	<p>Type 7 – Flexible hose with one or more reinforcement plies that may be fabric or steel, and an outer protective layer.</p>	<p>Wear or damage through the outer protective layer and outer cover, exposing a reinforcement ply.</p>

Section 1 – Power Train

ITEM AND METHOD OF INSPECTION:	REJECT IF:
1. Accelerator Pedal/Throttle Actuator	NOT APPLICABLE TO TRAILERS
2. Exhaust System <i>Additional Inspection Procedure(s):</i> Inspect with engine running. <i>Note:</i> Minor leaking and resulting soot tracks are normal at joints in diesel exhaust systems.	
a) manifold	a) broken, cracked, leaking, <i>loose</i> or <i>missing</i>
b) muffler <i>Note:</i> The <i>OEM</i> muffler or one that meets the <i>OEM standard</i> is required on every vehicle.	b) cracked, perforated or leaking bypassed, disabled, <i>missing</i> or removed deficient part is used that does <i>not</i> meet <i>OEM standard</i> patched in any manner other than by welding
c) resonator	c) cracked, leaking, <i>missing</i> or perforated patched in any manner other than by welding
d) exhaust pipe	d) cracked, collapsed or pinched, <i>missing</i> , perforated or leaking patched in any manner other than by welding
e) mounting hardware	e) broken, <i>insecure</i> or <i>loose</i> , or <i>missing</i> deficient part is used that does <i>not</i> meet <i>OEM standard</i>
f) heat shields <i>Note:</i> All heat shields provided by the <i>manufacturer</i> , installed as part of a retrofit for certain fuels, or installed for specialty applications, are considered required and must remain functional as intended.	f) a <i>required heat shield</i> is broken, <i>insecure</i> or <i>loose</i> , or <i>missing</i>

Note: All inspection procedures are visual unless additional inspection procedures are indicated. Conditions shown ***in this manner*** are defined conditions. The definitions can be found in the introduction section.

ITEM AND METHOD OF INSPECTION:	REJECT IF:
g) location	g) any part of the exhaust system is less than 50 mm away from a brake system component, any combustible material, or any part of the fuel system except a diesel or gasoline fuel tank, and is not protected by a heat shield any part of the exhaust system is less than 25 mm away from a diesel or gasoline fuel tank and is not protected by heat shield any exhaust component passes through an occupant compartment
h) turbocharger	h) leaking exhaust gases <i>level 2 leak</i> of engine oil
i) exhaust system and pipe termination	NOT APPLICABLE TO TRAILERS
<u>3. Emission Control Systems and Devices</u>	NOT APPLICABLE TO TRAILERS
<u>4. Drive Shaft</u>	NOT APPLICABLE TO TRAILERS
<u>5. Clutch and Clutch Pedal</u>	NOT APPLICABLE TO TRAILERS
<u>6. Engine/Transmission Mount</u>	NOT APPLICABLE TO TRAILERS

Note: All inspection procedures are visual unless additional inspection procedures are indicated. Conditions shown *in this manner* are defined conditions. The definitions can be found in the introduction section.

ITEM AND METHOD OF INSPECTION:	REJECT IF:
<u>7. Engine Shut Down</u>	NOT APPLICABLE TO TRAILERS
<u>8. Engine Start Safety Feature</u>	NOT APPLICABLE TO TRAILERS
<u>9. Gear Position Indicator</u>	NOT APPLICABLE TO TRAILERS
<u>10. Engine or Accessory Drive Belt</u>	NOT APPLICABLE TO TRAILERS
<u>11. Hybrid Electric Vehicle & Electric Vehicle Power Train System</u>	NOT APPLICABLE TO TRAILERS
<u>12. Gasoline or Diesel Fuel System</u> <i>Note:</i> This includes the fuel system for any auxiliary equipment or device.	
a) filler cap	a) allows spillage, improper type or <i>missing</i>
b) tank, filler neck/tube and vent tube	b) cracked, <i>insecure</i> mounting or weld is broken <u>not</u> intended for the storage of automotive fuel improper vent repair to any non-metallic tank
c) tank mount and strap	c) broken, cracked, <i>loose</i> or <i>missing</i> deficient part is used that does <u>not</u> meet <i>OEM standard</i> fastener is <i>loose</i> or <i>missing</i>
d) line, hose, fitting and connection <i>Note:</i> Refer to correct type of hose or tube and the related defective condition(s) as defined in the chart in the definition section of this standard.	d) chafing, cracked or <i>insecure</i> deficient product is used that does <u>not</u> meet <i>OEM standard</i> any section of a line, hose or tube is worn or <i>damaged</i> as shown in the chart on page 55*
e) fuel pump	e) <i>damaged</i> or <i>insecure</i>
f) leakage	f) <i>level 1 leak</i> of gasoline anywhere in a gasoline fuel system <i>level 2 leak</i> of diesel fuel anywhere in a diesel fuel system
	<u>Hazardous Condition(s)</u> i. <i>level 1 leak</i> of gasoline in gasoline fuel system ii. <i>level 2 leak</i> of diesel fuel in diesel fuel system iii. fuel cap is <i>missing</i> iv. fuel tank is <i>insecure</i> (a tank mounted with cushioning devices will have some movement)

Note: All inspection procedures are visual unless additional inspection procedures are indicated. Conditions shown *in this manner* are defined conditions. The definitions can be found in the introduction section.

ITEM AND METHOD OF INSPECTION:	REJECT IF:
<p><u>13. Pressurized or Liquefied Fuel System (LPG, CNG and LNG)</u></p>	
<p><i>Additional Inspection Procedure(s):</i> Inspect pressurized fuel systems according to the items listed below <u>unless</u> additional inspection is required by the applicable requirements of the jurisdiction where the inspection is being conducted. In some jurisdictions a full inspection of a pressurized fuel system may be conducted at a different time, as part of a different inspection program, or by a person with different qualifications.</p> <p><i>Note:</i> Refer to Appendix A for detailed criteria for inspecting Liquefied Petroleum Gas (LPG or Propane), Compressed Natural Gas (CNG) and Liquefied Natural Gas (LNG). When such an inspection is conducted, follow the applicable requirements of the relevant jurisdiction, or refer to the appropriate sections in Appendix A, as required.</p>	<p><u>Hazardous Condition(s)</u></p> <p>Any cause for rejection of a LPG, CNG or LNG system, except those shown with a double asterisk, will also mean an automatic “Hazardous Condition” of that vehicle. The cause for rejection must be corrected and the vehicle “passed” before it may be operated on the highway.</p>
<p>a) regulatory authority decal</p>	<p>a) **decal is not displayed</p> <p>**an incorrect decal is affixed to vehicle</p> <p>**information on decal is <u>not</u> readable</p> <p>Despite the note above, the conditions listed here with a double asterisk (**) are not Hazardous Conditions</p>
<p>b) pressure vessel (tank or cylinder) and valve, location and mounting</p>	<p>b) pressure vessel (tank or cylinder) is <i>insecure</i> or <i>loose</i>, or welds are broken</p> <p>welding has been done anywhere on a pressure vessel (tank or cylinder) except on saddle plates or bracket</p> <p>tank or cylinder valve and their connections are <i>insecure</i> or <i>loose</i></p> <p>tank or cylinder valve and their connections are <u>not</u> protected from damage due to stationary objects, or objects from the road</p> <p>pressure vessel (tank or cylinder) is located above the vehicle or projects beyond vehicle side, ahead of front axle or behind rear bumper</p> <p>any part of exhaust system is less than 200 mm away from any part of the fuel system and is <u>not</u> protected by shields</p> <p>a heat shield is less than 25 mm away from any fuel system component</p>

Note: All inspection procedures are visual unless additional inspection procedures are indicated. Conditions shown *in this manner* are defined conditions. The definitions can be found in the introduction section.

ITEM AND METHOD OF INSPECTION:	REJECT IF:
<p>c) pressure vessel (tank or cylinder) ground clearance</p> <p><i>Note:</i> Includes any attached fitting or valve the appropriate sections in Appendix A, as required.</p>	<p>c) distance to ground from bottom of pressure vessel (tank or cylinder) is less than minimum ground clearance shown below</p> <p>pressure vessel (tank or cylinder) located between axles</p> <p>wheelbase of 3225 mm <u>or less</u>: minimum ground clearance = 170 mm</p> <p>wheelbase <u>over</u> 3225 mm: minimum ground clearance = 220 mm</p> <p>pressure vessel (tank or cylinder) located behind rear axle</p> <p>minimum ground clearance = 200 mm</p> <p>any portion of the tank or cylinder protrudes past the plane formed by the bottom of the rear most tires and the lowest most rearward part of the vehicle.</p>
<p>d) pressure vessel (tank or cylinder) sub-frame</p>	<p>d) any modification has been made to pressure vessel (tank or cylinder) carrier or sub-frame, that <u>does not</u> meet <i>OEM standard</i> or <i>industry standard</i></p>
<p>e) pressure vessel (tank or cylinder) information plate and data</p> <p><i>Note:</i> Pressure vessel installed as part of an <i>OEM</i> vehicle gaseous fuels installation may not have an information plate affixed to it.</p>	<p>e) name plate is missing or illegible, or data is <u>not</u> shown on plate (see note below)</p> <p><i>Note:</i> When information plate is illegible or missing, record it on the inspection report, however do not reject the vehicle for this condition alone.</p>
<p>f) pressure vessel (tank or cylinder) filler cap</p>	<p>f) protective filler cap <u>not</u> secured to filler valve or vehicle</p>
<p>g) pressure vessel (tank or cylinder) remote filler box</p>	<p>g) not adequately sealed to prevent vapour migration into vehicle interior (trunk etc.)</p>
<p>h) main shut-off valve</p>	<p>h) valve is <u>not</u> readily accessible (<u>cannot</u> be reached)</p>
<p>i) corrosion protection</p>	<p>i) protective coating or material is <i>damaged</i>, or is missing from externally mounted pressure vessel (tank) or attachment</p>
<p>j) fitting, hose, piping and tubing</p>	<p>j) is <i>insecure</i>, or any anchor support is <i>damaged</i> or <i>missing</i></p> <p>is <u>not</u> protected against corrosion</p> <p>grommet is <i>damaged</i> or <i>missing</i></p> <p>components in trunk area <u>not</u> protected against luggage</p>
<p>k) fuel system leakage</p>	<p>k) any fuel system leak is detected</p>
<p>l) pressure relief valve</p>	<p>l) incorrectly installed or <i>missing</i></p>

Note: All inspection procedures are visual unless additional inspection procedures are indicated. Conditions shown ***in this manner*** are defined conditions. The definitions can be found in the introduction section.

ITEM AND METHOD OF INSPECTION:	REJECT IF:
m) supply lock off valve (LPG)	m) does <u>not</u> operate as originally intended
n) excess flow valve (LPG) and cap	n) <i>missing</i>
o) vehicle chassis and under-body	o) a structural member has been altered in any manner that does <u>not</u> meet <i>OEM standard</i> or <i>industry standard</i>
	<p><u>Hazardous Condition(s)</u></p> <p>Any cause for rejection of a LPG, CNG or LNG system, except those shown with a double asterisk, will also mean an automatic “Hazardous Condition” of that vehicle. The cause for rejection must be corrected and the vehicle “passed” before it may be operated on the highway.</p>

Note: All inspection procedures are visual unless additional inspection procedures are indicated. Conditions shown *in this manner* are defined conditions. The definitions can be found in the introduction section.

Section 2 – Suspension

ITEM AND METHOD OF INSPECTION:	REJECT IF:
<p><u>1. Suspension & Frame Attachments</u></p> <p><i>Note:</i> This section applies to all types of suspension.</p> <p><i>Manufacturer</i> welding of components is a normal part of many manufacturing processes and is distinct from welding to modify or repair a part.</p> <p><i>Additional Inspection Procedure(s):</i> Raise the vehicle as necessary to access the suspension components.</p>	
<p>a) vehicle ride height</p> <p><i>Additional Inspection Procedure(s):</i> Check ride height while vehicle is parked on a flat level surface.</p>	<p>a) suspension is sagged so that the vehicle ride height, on a vehicle other than a bus, is more than 50 mm from manufacturer specified height when measured at the tire centreline</p> <p>one side of the vehicle is more than 50 mm, higher or lower than the other when measured at the tire centreline</p>
<p>b) frame bracket, mounting bracket and hanger</p> <p><i>Note:</i> Some trailer suspension systems use a “cross tube brace”, consisting of a pipe positioned between the spring hangers on either side of the vehicle. The “cross tube brace” is used to position the suspension for shipment and installation and has no bearing on the alignment or the function of the suspension.</p>	<p>b) broken, cracked, <i>damaged, loose, missing</i>, or perforated due to corrosion or deterioration</p> <p>welded or repaired in a way that does <u>not</u> meet <i>OEM standard</i></p>
<p>c) mounting fasteners</p>	<p>c) broken, cracked, <i>loose</i> or <i>missing</i></p>
	<p><u>Hazardous Condition(s)</u></p> <ul style="list-style-type: none"> i. an axle has shifted or is able to shift from its normal position ii. any attaching component is broken, cracked, <i>loose</i> or <i>missing</i> iii. the condition of the suspension system allows a tire to contact any part of the vehicle frame or body
<p><u>2. Axle Attaching & Tracking Components</u></p> <p><i>Note:</i> This section applies to all types of suspension.</p> <p><i>Additional Inspection Procedure(s):</i> Raise the vehicle as necessary to access the suspension components. Inspect using hand pressure and suitable tools.</p>	

Note: All inspection procedures are visual unless additional inspection procedures are indicated. Conditions shown ***in this manner*** are defined conditions. The definitions can be found in the introduction section.

ITEM AND METHOD OF INSPECTION:	REJECT IF:
a) axle attachment, axle saddle	a) bent, broken, cracked, <i>loose</i> or <i>missing</i> axle has shifted from its normal position
b) bushing (rubber or composite material)	b) <i>loose</i> or shifted out of place, <i>missing</i> , worn beyond <i>manufacturer</i> specification wear or damage permits axle or wheel to shift out of position
c) suspension connecting component, (e.g.: arm, torque rod, radius rod, strut, track rod, control arm) <i>Note:</i> Some suspension connecting components are supplied as unfinished two-piece assemblies that require welding once the required length is established. This type of welding is not cause for rejection.	c) bent, broken, cracked, <i>loose</i> , <i>missing</i> , worn beyond <i>manufacturer</i> specifications, or perforated due to corrosion or deterioration welded or repaired in a way that does <u>not</u> meet <i>OEM standard</i> wear or damage permits axle or wheel to shift out of position
d) stabilizer/anti-sway bar or link	d) bent, broken, cracked, <i>loose</i> , <i>missing</i> or worn beyond <i>manufacturer</i> specification welded or repaired in a way that does <u>not</u> meet <i>OEM standard</i>
e) equalizer or “walking” beam	e) broken, cracked or bushing mounting holes are elongated welded or repaired in a way that does <u>not</u> meet <i>OEM standard</i> wear in suspension allows tires to contact frame axles do <u>not</u> align correctly
	<u>Hazardous Condition(s)</u> i. an axle has shifted or is able to shift from its normal position ii. any attaching component is broken, cracked, <i>loose</i> or <i>missing</i> iii. the condition of the suspension system allows a tire to contact any part of the vehicle frame or body

Note: All inspection procedures are visual unless additional inspection procedures are indicated. Conditions shown ***in this manner*** are defined conditions. The definitions can be found in the introduction section.

ITEM AND METHOD OF INSPECTION:	REJECT IF:
<u>3. Axle & Axle Assembly</u>	
a) condition	a) axle is bent or <i>damaged</i> axle material or a weld is cracked <i>loose</i> or shifted out of normal position welded or repaired in a way that does <u>not</u> meet <i>OEM standard</i>
	<u>Hazardous Condition(s)</u> i. axle has shifted or is able to shift from its normal position ii. axle material or a weld is cracked
<u>4. Spring & Spring Attachment</u>	
a) leaf spring	a) any spring leaf is broken, cracked, <i>missing</i> , or is shifted out of place any spring leaf is worn more than 3 mm in the hanger contact area or where leaves are in contact with each other leaf is shifted and contacting another vehicle part
b) composite spring <i>Note:</i> Some change in the appearance of a composite spring, described as “fuzzing” is normal as the spring ages. A crack of a composite spring is a separation in any axis which passes completely through the spring.	b) worn more than 3 mm in load bearing area broken, crack of any length visible on both sides of a spring, splintered, delaminating or <u>not</u> the same type on each side of vehicle
c) shackle, pin, bushing <i>Additional Inspection Procedure(s):</i> Check the wear of the spring pins according to <i>manufacturer</i> service instructions.	c) broken, <i>loose</i> or <i>missing</i> shifted out of normal position fastener <i>loose</i> or <i>missing</i> vertical movement of a spring or shackle against a spring pin exceeds <i>OEM standard</i> or if <u>not</u> available; wear exceeds limit below For pin size of 12.5 mm to 25 mm: wear limit is 2.0 mm For pin size of 25 mm to 45 mm: wear limit is 3.0 mm
d) U-bolt & hardware	d) broken, cracked, <i>loose, missing</i> , or shifted out of normal position welded or repaired in a way that does <u>not</u> meet <i>OEM standard</i>

Note: All inspection procedures are visual unless additional inspection procedures are indicated. Conditions shown ***in this manner*** are defined conditions. The definitions can be found in the introduction section.

ITEM AND METHOD OF INSPECTION:	REJECT IF:
e) spring contact area of hanger (slipper) <i>Note:</i> Wear plates are permitted by some manufacturers in the spring contact (slipper) area of fabricated hangers.	e) repaired by welding (except installation of wear plates) spring load bearing area is worn more than 3 mm
f) coil spring	f) broken or shifted out of normal position spacer is used between the coils of a spring
g) torsion bar	g) broken, cracked or <i>missing</i> <i>repaired by welding</i>
h) bump pad	h) <i>loose, missing</i> or split
i) rubber load cushion	i) rubber block or vertical pin is broken, <i>loose, missing</i> or split
	<p><u>Hazardous Condition(s)</u></p> <ul style="list-style-type: none"> i. any metal spring leaf is <i>missing</i>, or has leaves shifted out of place ii. the main leaf or more than 25% of the leaves of a metal leaf spring are cracked iii. spring leaf is shifted and in contact with a rotating part iv. a composite spring is broken, has a crack of any length intersecting with another crack, or a crack longer than $\frac{3}{4}$ the length of the spring v. torsion bar is broken or cracked vi. coil spring is broken vii. a rubber load cushion is <i>missing</i> or separated
<p><u>5. Air Suspension</u></p> <p><i>Note:</i> This section applies to fixed axle and liftable axle suspension systems.</p> <p><i>Additional Inspection Procedure(s):</i> Check with air system at normal operating pressure, liftable suspension in lowered position, and with supports placed under the vehicle to protect against dropping of the vehicle in the event of air loss.</p> <p>Maintain appropriate air pressure in any liftable axle system.</p>	
a) ride height	a) height is 50 mm above or below <i>OEM</i> specification vehicle leans to one side or air spring pressure is unequal

Note: All inspection procedures are visual unless additional inspection procedures are indicated. Conditions shown *in this manner* are defined conditions. The definitions can be found in the introduction section.

ITEM AND METHOD OF INSPECTION:	REJECT IF:
b) air spring (air bag)	b) improperly seated, <i>missing</i> , patched or reinforcing ply is exposed due to damage or deterioration air leak
c) air spring base, mounting plate	c) broken, cracked or <i>missing</i> perforated by corrosion or deterioration welded or repaired in a way that does <u>not</u> meet <i>OEM standard</i>
d) air system <i>Additional Inspection Procedure(s):</i> Inspect the function and operation of the air suspension system and controls in accordance with <i>manufacturer</i> service instructions.	d) pressure protection valve is <i>inoperative</i> or <i>missing</i> control, pressure regulator or gauge, is <i>inoperative</i> or <i>missing</i>
e) air line, connection and fitting <i>Note:</i> Refer to correct type of hose or tube and the related defective condition(s) as defined in the chart in the definition section of this standard.	e) fitting, line, repair method, installation or modification does <u>not</u> meet <i>OEM standard</i> tubing or hose is defective as defined in the chart on page 5 fitting or connection is broken, cracked, flattened or leaking <i>damaged</i> in a way (such as: melting, flattening, deformation or kinking) that can restrict air flow
f) height control valve	f) <i>inoperative</i> a system originally equipped with 2 valves has a valve <i>missing</i> or has been converted to a single valve a system with only one valve has the valve positioned in a location other than near the centre of an axle
g) kneeling feature <u>on a bus</u>	NOT APPLICABLE TO TRAILERS
	<u>Hazardous Condition(s)</u> i. an air spring (air bag) is <i>missing</i> , deflated or has an air leak

Note: All inspection procedures are visual unless additional inspection procedures are indicated. Conditions shown ***in this manner*** are defined conditions. The definitions can be found in the introduction section.

ITEM AND METHOD OF INSPECTION:	REJECT IF:
<p><u>6. Self-Steer and Controlled-Steer Axle</u></p> <p><i>Note:</i> The suspension components on a self-steer or controlled steer axle must be inspected according to items 1-4 in this section. The steering components must be inspected according to Section 4.</p>	
<p><u>7. Shock Absorber/Strut Assembly</u></p>	
<p>a) condition</p>	<p>a) <i>damaged</i>, detached, or <i>missing</i> binding strut bearing/mount prevents free rotation of the steering wheel</p>
<p>b) mount & hardware</p>	<p>b) broken, <i>loose</i> or <i>missing</i></p>
<p>c) oil leak</p>	<p>c) <i>level 2 leak</i> of oil</p>
	<p><u>Hazardous Condition(s)</u></p> <p>i. <u>a shock absorber on air ride suspension is broken, detached, or <i>missing</i></u></p>

Note: All inspection procedures are visual unless additional inspection procedures are indicated. Conditions shown ***in this manner*** are defined conditions. The definitions can be found in the introduction section.

Section 3 – Brake Systems

A. OPTIONS FOR INSPECTING INTERNAL BRAKE COMPONENTS OF HYDRAULIC AND AIR BRAKE SYSTEMS**1. Types of Brake Inspections**

This standard supports several different types of brake inspections depending on the age of a vehicle, the type of brakes being inspected, the required cycle of inspections that applies to a vehicle, i.e.: 12 month or 6 months, and the type of inspection previously completed.

There are three types of inspection for drum brakes:

- A. *Full inspection with drum removed* (this is a detailed inspection of all internal components {listed in Section 3H 12 and 3A 15 & 16} and includes measuring drums and shoe lining)

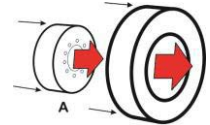

- B. *Wheel-on full inspection* (this is only available for cam-type drum brakes with removable dust shields and involves an inspection of the internal components {listed in Section 3A 15 & 16} with the dust shields removed, it includes measuring drums and shoe lining)

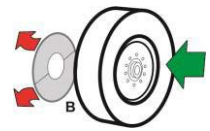

- C. *Limited-inspection of drum brake* (this is an inspection through inspection holes and involves a measurement of shoe lining only)

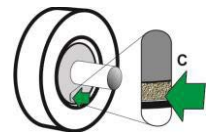
**There are two types of inspection for disc brakes**

- D. *Full inspection with wheel(s) removed* (this is a detailed inspection of all internal components {listed in Section 3H 13 and 3A 18} and includes measuring rotor and pad friction material thickness)

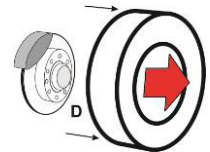

- E. *Limited-inspection of disc brake* (this is an inspection of visually accessible components and measurement of the friction material of one brake pad)

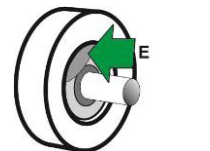

To determine what inspection must be conducted, refer to the following instructions.

2. Disassembly of Wheels and/or Drums for Inspection

Disassembly of brakes provides access to ensure all components are fully inspected. Full inspection with either drum or wheel removal is required when any defect is suspected or found during an inspection.

Suspecting a defect of any wheel brake must be based on some visible evidence that could indicate the presence of a problem or abnormal condition. The following conditions are those that should cause a technician-inspector to suspect a brake defect:

- abnormal wear of friction material
- signs of overheating
- evidence of negative effects of corrosion (“rust-jacking”, friction material lifting due to rust build-up, shoe table deformation, friction material separating from backing material)

Note: All inspection procedures are visual unless additional inspection procedures are indicated.

Conditions shown *in this manner* are defined conditions. The definitions can be found in the introduction section.

- abnormal wear of the brake drum or rotor
- abnormal appearance, glazing, discolouration or contamination of brake friction material
- damage, distortion or shifting out of place of any brake component
- abnormal noise or response upon application or release of the brakes
- the age of the brake components, or the previous measurements of wear compared to current measurements, indicate that a drum or rotor, or friction material, is likely to be worn beyond the allowable limit

Note: When any of these conditions is evident or is suspected, that brake does not qualify for a “wheel-on full inspection” or a “limited inspection”. A “full inspection with drum removed” is required in the case of drum brakes and a “full inspection with wheel(s) removed” is required in the case of disc brakes.

3. Exemptions from Brake Disassembly for Drum Brakes

When a “full inspection with drum removed (‘A’)” is conducted on a truck or trailer having drum brakes, and the proper documentation is completed, the brake can qualify for a “limited inspection (‘C’)” for a period of 19 months. Buses with drum brakes, only qualify for a limited inspection for 7 months following a “full inspection with drum removed”. A “limited inspection (‘C’)” can only be conducted during the respective 7 or 19 month qualifying period after completing a “full inspection with drum removed”; but only when such inspection is properly documented.

A cam-type drum brake with removable dust cover/shields also qualifies for a “*wheel-on full inspection (‘B’)*” at each inspection. This option is only available for cam type drum brakes; but only when the dust cover/shields are left off the vehicle or are removed to facilitate the inspection.

4. Exemptions from Wheel Disassembly for Disc Brakes

Disc brakes require a “full inspection with wheel(s) removed (‘D’)” at least every 12 months. When a “full inspection with wheel(s) removed (‘D’)” is conducted on a disc brake, and the proper documentation is completed, the brake can qualify for a “*limited inspection (‘E’)*” for a period of 7 months.

5. Exemptions from Brake/Wheel Disassembly for New Vehicles

Brakes are exempt from the requirement to disassemble when vehicles are new. The exemption period depends on the type of brake used and is based on the vehicle manufacture date or in-service date. Trucks and trailers using drum brakes qualify for a “*limited inspection (‘C’)*” for a period of 19 months. Trucks and trailers with disc brakes, and all buses qualify for a “*limited inspection (‘C’) or (‘E’)*” for a period of 7 months.

Note: All inspection procedures are visual unless additional inspection procedures are indicated. Conditions shown *in this manner* are defined conditions. The definitions can be found in the introduction section.

6. Summary of Inspection Requirements for Trucks and Trailers on 12-Month Inspection Cycle

INSPECTION REQUIRED FOR NEW TRUCKS AND TRAILERS on 12 month inspection cycle

Brake used	Inspection required when vehicle is	
	12 mo. old	24 mo. old
Drum with <u>removable dust shields</u>	C	A or B
Drum with <u>rigid backing plate</u>	C	A
Disc	D	D

ONGOING BRAKE INSPECTION OPTIONS for Truck & Trailer on 12 month inspection cycle

Brake used	Type of inspection last completed (Starting Month)	Inspection required ¹	
		12 mo. later	24 mo. later
Drum with <u>removable dust shields</u>	<i>full inspection with drum removed (A)</i>	C ²	A or B
	<i>wheel-on full inspection (B)</i>	B	B
Drum with <u>rigid backing plate</u>	<i>full inspection with drum removed (A)</i>	C ²	A
Disc	<i>full inspection with wheel(s) removed (D)</i>	D	D

¹ This is the minimum inspection that is permitted. A full inspection is always permitted.

² A *limited inspection* is only permitted when proper documentation of a *full inspection with drum or wheel(s) removed* is provided.

Types of inspections

Drum	<i>full inspection with drum removed</i>	'A'
Brakes	<i>wheel-on full inspection</i>	'B'
	<i>limited-inspection of drum brake</i>	'C'
Disc	<i>full inspection with wheel(s) removed</i>	'D'
Brakes	<i>limited-inspection of Disc brake</i>	'E'

7. Summary of Inspection Requirements for Trucks on 6-Month Inspection Cycle

Note: Only applicable in YK, BC, SK & MB.

INSPECTION REQUIRED FOR NEW TRUCK on 6 month inspection cycle

Brake used	Inspection required when vehicle is			
	6 mo. old	12 mo. old	18 mo. old	24 mo. old
Drum with <u>removable dust shields</u>	C	C	C	A or B
Drum with <u>rigid backing plate</u>	C	C	C	A
Disc	E	D	E	D

Note: All inspection procedures are visual unless additional inspection procedures are indicated.

Conditions shown *in this manner* are defined conditions. The definitions can be found in the introduction section.

ONGOING BRAKE INSPECTION OPTIONS for Truck on 6 month inspection cycle

Brake used	Type of inspection last completed (Starting Month)	Inspection required ¹			
		6 mo. later	12 mo. later	18 mo. later	24 mo. later
Drum with <u>removable dust shields</u>	<i>full inspection with drum removed (A)</i>	C ²	C ²	C ²	A
	<i>wheel-on full inspection (B)</i>	B	B	B	B
Drum with <u>rigid backing plate</u>	<i>full inspection with drum removed (A)</i>	C ²	C ²	C ²	A
Disc	<i>full inspection with wheel(s) removed (D)</i>	E ²	D	E ²	D

¹ This is the minimum inspection that is permitted. A full inspection is always permitted.

² A *limited inspection* is only permitted when proper documentation of a *full inspection with drum or wheel(s) removed* is provided.

8. Summary of Inspection Requirements for Buses**INSPECTION REQUIRED FOR NEW Bus**

Brake used	Inspection required when vehicle is			
	6 mo. later	12 mo. later	18 mo. later	24 mo. later
Drum with <u>removable dust shields</u>	C	A	C	A
	C	B	B	B
Drum with <u>rigid backing plate</u>	C	A	C	A
Disc	E	D	E	D

ONGOING BRAKE INSPECTION OPTIONS for Buses

Brake used	Type of inspection last completed (Starting Month)	Inspection required ¹			
		6 mo. later	12 mo. later	18 mo. later	24 mo. later
Drum with <u>removable dust shields</u>	<i>full inspection with drum removed (A)</i>	C ²	A	C ²	A
	<i>wheel-on full inspection (B)</i>	B	B	B	B
Drum with <u>rigid backing plate</u>	<i>full inspection with drum removed (A)</i>	C ²	A	C ²	A
Disc	<i>full inspection with wheel(s) removed (D)</i>	E ²	D	E ²	D

¹ This is the minimum inspection that is permitted. A full inspection is always permitted.

² A *limited inspection* is only permitted when proper documentation of a *full inspection with drum or wheel(s) removed* is provided.

Types of inspections

Drum	<i>full inspection with drum removed</i>	'A'
Brakes	<i>wheel-on full inspection</i>	'B'
	<i>limited-inspection of drum brake</i>	'C'
Disc	<i>full inspection with wheel(s) removed</i>	'D'
Brakes	<i>limited-inspection of Disc brake</i>	'E'

Note: All inspection procedures are visual unless additional inspection procedures are indicated.

Conditions shown *in this manner* are defined conditions. The definitions can be found in the introduction section.

B. REQUIRED MEASUREMENT OF BRAKE COMPONENTS

Brake inspections require certain components to be measured and these measurements are required to be recorded on a record/report of the inspection. The items that must be measured for each type of brake are as follows:

1. Drum Brake Systems

For drum brakes, the brake shoe lining thickness and brake drum diameter must be measured during every “*full inspection with drum removed (A)*” and every “*wheel-on full inspection (B)*”.

When a “*limited-inspection (C)*” of drum brakes is conducted, the lining thickness of one brake shoe must be recorded. The measurement must be taken of the thinnest accessible portion of the thinnest brake shoe lining.

2. Disc Brake Systems

For disc brakes, the rotor thickness and pad friction material thickness of the inner and outer brake pad must be measured and recorded at every inspection, unless the brake qualifies for a “*limited-inspection (E)*”.

When a “*limited-inspection (E)*” of disc brakes is conducted, the thickness of the friction material of one of the pads must be recorded. Normally this will be the inner pad.

Friction material thickness can be determined by measuring the friction material itself or by measuring the combined thickness of the friction material and pad backing plate, then deducting the thickness of the backing plate. Always record the thickness of the friction material only.

C. DOCUMENTS REQUIRED FOR QUALIFYING A PRIOR INSPECTION OF INTERNAL BRAKE COMPONENTS

Qualifying a prior inspection with respect to a wheel brake requires an original of a document containing the information listed below to be submitted to the inspecting technician and inspection facility conducting a current inspection.

A legible copy of the required document must also be submitted to the inspection facility for attachment to the inspection report. The technician-inspector and inspection facility must be satisfied with the documentation provided.

Information to be Included on the Proof of Brake Inspection Document:

The information that must be included on a document used to prove a prior inspection includes information common to all brakes and information specific to drum and disc brakes, as follows:

1. Common Information

- Date of inspection
- Odometer reading (Optional for trailers. Record either the hub-odometer or ABS ECU mileage, if either is available, including which source was used.)
- VIN
- Authorized technician/inspector’s name and/or number and signature (in written or electronic form).
- Inspection station name and number, or name and location of repair facility (based on jurisdictional requirements).

2. Additional Information Required for Drum Brakes

- If new brake shoe lining and/or brake drums were installed, the document must show them as ‘new’ and be supported by documentation, such as purchase invoice, work order, etc.
- Internal diameter of the brake drum.
- Thickness of the brake shoe lining taken at the edge of the lining near the centre of the brake shoe. The measurement must be taken of the thinner brake shoe lining, when there is a difference in thickness.
- The document must include a declaration stating that the brake drum was removed and a “*full inspection with drum removed (A)*” was conducted, and that no defective component was present at the completion of the inspection.

Note: All inspection procedures are visual unless additional inspection procedures are indicated.

Conditions shown *in this manner* are defined conditions. The definitions can be found in the introduction section.

3. Additional Information Required for Disc Brakes

- If new brake pads and/or rotor were installed, the document must show them as 'new' and be supported by documentation, such as purchase invoice, work order, etc.
- Thickness of the rotor.
- Thickness of the thinnest pad friction material.
- Brake pad friction material measurements must be taken at the thinnest point of the material.
- The document must include a declaration stating that the wheel(s) was/were removed and a "full inspection with wheel(s) removed ('D')" was conducted, and that no defective component was present at the completion of the inspection.

D. PROHIBITION ON REMOVAL OF BRAKES FROM A VEHICLE

Axles fitted with brakes by the *manufacturer* as original equipment must have those brakes in proper working order, and the brakes must be inspected in accordance with this standard. Brakes must not be disabled or removed from a vehicle.

Note: All inspection procedures are visual unless additional inspection procedures are indicated.
Conditions shown *in this manner* are defined conditions. The definitions can be found in the introduction section.

Section 3H – Hydraulic Brakes

ITEM AND METHOD OF INSPECTION:	REJECT IF:
<p>1. Hydraulic System Components</p> <p>a) metal line and fittings</p> <p><i>Additional Inspection Procedure(s):</i> Inspect lines and fittings for leaks while brakes are fully applied with heavy force on the brake pedal, (i.e.: panic stop). Operate engine if necessary to maintain power-assist.</p> <p><i>Note:</i> All connections between brake system components must be proper flared type.</p> <p><i>Note:</i> Surface rust and corrosion is normal on metal lines and fittings, and is not cause for rejection.</p>	<p>a) heavy rust, corrosion or scaling, is present on any metal line or fitting that reduces or increases the thickness, or compromises the structural integrity of the material</p> <p><u>level 1 leak</u> of brake fluid</p> <p>chafing, cracked, flattened or restricting section</p> <p><u>insecure</u> mounting causing line to shift out of its normal position</p> <p>repaired by welding or soldering</p> <p>repaired using material or method does <u>not</u> meet <u>OEM standard</u></p>
<p>b) flexible line/hose</p> <p><i>Additional Inspection Procedure(s):</i> Inspect flexible hoses while brakes are applied with heavy force on the brake pedal, (i.e.: panic stop). Operate engine if necessary to maintain power-assist.</p>	<p>b) bulged or swells under pressure, flattened, twisted, restricting section or <u>insecure</u> mounting</p> <p>outer composite material is cracked or chafed exposing an inner layer as shown in hose and tube condition chart in introduction</p> <p>deficient product is used that does <u>not</u> meet <u>OEM standard</u></p>
<p>c) master cylinder</p>	<p>c) <u>damaged</u> or <u>insecure</u> mounting</p> <p>fluid is contaminated</p> <p><u>level 1 leak</u> of brake fluid</p> <p>fluid level is below indicated minimum level, or if <u>not</u> indicated, more than 13 mm from top</p> <p>filler cap is <u>damaged</u>, <u>loose</u> or <u>missing</u>, vent holes are plugged, or gasket is <u>missing</u> or swollen</p>
<p>d) pressure differential switch</p>	<p>d) switch or electrical connection is <u>damaged</u>, <u>insecure</u> or <u>loose</u></p> <p><u>level 1 leak</u> of brake fluid</p> <p><u>inoperative</u></p>
<p>e) variable or proportioning system</p> <p><i>Additional Inspection Procedure(s):</i> Check links for mechanical defects. Test when there is evidence of a problem. Refer to <u>manufacturer</u> service instructions and confirm that the valve is functioning properly.</p>	<p>e) link is <u>damaged</u>, <u>missing</u>, or seized</p> <p><u>inoperative</u></p> <p><u>level 1 leak</u> of brake fluid</p>

Note: All inspection procedures are visual unless additional inspection procedures are indicated. Conditions shown **in this manner** are defined conditions. The definitions can be found in the introduction section.

ITEM AND METHOD OF INSPECTION:	REJECT IF:
f) auxiliary or work brake (line-lock device) <i>Note:</i> Line-lock devices block brake fluid from returning to the master cylinder as a means of holding a vehicle stationary. Improperly installed they can interfere with normal service brake operation.	f) any device is installed that interferes with normal service brake operation
	<u>Hazardous Condition(s)</u> i. a brake hose or line swells under pressure ii. <i>level 2 leak</i> in any part of the brake system iii. brake pedal moves downward when brakes are held applied iv. a brake hose is broken, crimped, restricted, or cracked exposing any inner layer v. master cylinder fluid level is below indicated minimum level or less than ¼ full vi. brake fluid is contaminated in a way that prevents normal brake operation
<u>2. Brake Pedal/Actuator</u>	NOT APPLICABLE TO TRAILERS
<u>3. Vacuum Assist (Boost) System on Truck or Bus</u>	NOT APPLICABLE TO TRAILERS
<u>4. Hydraulic Assist (Boost) System on Truck or Bus</u>	NOT APPLICABLE TO TRAILERS
<u>5. Air Assist (Boost) System on Truck or Bus</u>	NOT APPLICABLE TO TRAILERS
<u>6. Air-Over-Hydraulic Brake System</u> <i>Note:</i> An Air-Over-Hydraulic Brake System is a brake system that uses compressed air to transmit force from the driver control to a hydraulic brake fluid system that actuates the service brakes. The brake pedal is connected to an air valve that delivers air pressure to hydraulic pressure converters. <i>Note:</i> The air system of an air-over-hydraulic brake system must comply with <u>CMVSS</u> 121.	

Note: All inspection procedures are visual unless additional inspection procedures are indicated. Conditions shown *in this manner* are defined conditions. The definitions can be found in the introduction section.

ITEM AND METHOD OF INSPECTION:	REJECT IF:
<p>a) operation</p> <p><i>Additional Inspection Procedure(s):</i> Inspect system operation according to <u>manufacturer</u> service instructions.</p> <p>When no <u>manufacturer</u> service instructions are available, inspect the air supply system for compliance with the items 1 – 6 in Section 3A Air Brakes. Inspect the hydraulic system components for compliance with all relevant items listed in this Section.</p>	<p>a) system does <u>not</u> operate as described in manufacturer service instructions</p> <p>a vehicle manufactured after 1975 does <u>not</u> have a dual-circuit air system and two independent air-to- hydraulic pressure converters</p> <p>any system defect or malfunction is detected</p>
	<p><u>Hazardous Condition(s)</u></p> <p>i. a brake hose or line swells under pressure</p> <p>ii. <u>level 2 leak</u> in any part of the brake system</p> <p>iii. applied pedal travel exceeds 80% of total pedal travel</p> <p>iv. power assist unit is <u>inoperative</u></p> <p>v. a check valve is <u>inoperative</u> or <u>missing</u></p> <p>vi. the brake pedal does not move downward when the engine is started with the brakes applied</p>
<p><u>7. Surge Brake Controller on Trailer</u></p>	
<p>a) controller operation</p> <p><i>Additional Inspection Procedure(s):</i> Check the operation of the surge brake controller according to the manufacturer service instructions. Actuate the controller using suitable means and confirm brake operation at each wheel. Test operation of any backing mechanism.</p>	<p>a) controller is <u>damaged</u> or defective</p> <p>controller is seized, or fails to operate brakes when actuated manually</p> <p>backing/towing function fails to <u>operate as intended</u></p>
<p>b) brake fluid reservoir</p>	<p>b) <u>insecure</u> mounting or <u>loose</u></p> <p><u>level 1 leak</u> of brake fluid</p> <p>brake fluid level is below 'fill' or 'min.' mark or less than 75% of capacity when reservoir is not marked</p> <p>reservoir filler cap <u>damaged, loose</u> or <u>missing</u></p>
<p>c) break-away device</p> <p><i>Note:</i> A break-away device is not required in all jurisdictions. Inspect according to the <u>applicable requirements</u>.</p> <p><i>Additional Inspection Procedure(s):</i> When a break-away device is present, it must be inspected according to the service instructions provided by the <u>manufacturer</u> and it must be functional.</p>	<p>c) <u>missing</u> from a trailer required to have a break-away device</p> <p><u>damaged</u>, improperly installed or <u>inoperative</u></p>

Note: All inspection procedures are visual unless additional inspection procedures are indicated. Conditions shown **in this manner** are defined conditions. The definitions can be found in the introduction section.

ITEM AND METHOD OF INSPECTION:	REJECT IF:
	<p><u>Hazardous Condition(s)</u></p> <p>i. brakes are <i>inoperative</i> or fail to <i>operate as intended</i></p> <p>ii. required break-away device is improperly installed, <i>inoperative</i> or <i>missing</i></p>
<p><u>8. Vacuum System on Trailer</u></p> <p><i>Additional Inspection Procedure(s):</i> When inspecting a trailer that uses vacuum to actuate or boost braking, inspect the system according to the service instructions provided by the <i>manufacturer</i>.</p>	
a) condition and operation	a) <i>damaged</i> or fails to <i>operate as intended</i>
	<p><u>Hazardous Condition(s)</u></p> <p>i. brakes are <i>inoperative</i> or fail to <i>operate as intended</i></p>
<p><u>9. Air-Boosted Trailer Brake System</u></p> <p><i>Additional Inspection Procedure(s):</i> When inspecting a trailer that uses an air-boosted brake system, inspect the system according to the service instructions provided by the <i>manufacturer</i>.</p>	
a) condition and operation	a) <i>damaged</i> or fails to <i>operate as intended</i>
	<p><u>Hazardous Condition(s)</u></p> <p>i. brakes are <i>inoperative</i> or fail to <i>operate as intended</i></p>
<p><u>10. Electric Brake System on Trailer</u></p> <p><i>Additional Inspection Procedure(s):</i> Wheels and drums must be disassembled on all electric brake systems.</p> <p><i>Note:</i> Inspect the wheel-end (drum or disc) brake system components, on a trailer with electric brakes, according to the relevant requirements for drum or disc brake system as outlined in this section below.</p>	
<p>a) wheel magnet and actuator</p> <p><i>Additional Inspection Procedure(s):</i> When the <i>manufacturer</i> of the brake system provides a test procedure for confirming the operation of the electromagnet used to actuate the brake, the test procedure must be conducted as part of the inspection.</p>	<p>a) any part is broken, <i>damaged</i>, <i>loose</i>, or <i>missing</i></p> <p>magnet is <i>inoperative</i> or seized</p>

Note: All inspection procedures are visual unless additional inspection procedures are indicated. Conditions shown *in this manner* are defined conditions. The definitions can be found in the introduction section.

ITEM AND METHOD OF INSPECTION:	REJECT IF:
b) wiring	b) shorted, insulation is cracked or peeled improperly spliced or connected not secured at least every 1800 mm
c) break-away device <i>Note:</i> A break-away device is not required in all jurisdictions. Inspect according to the <u>applicable requirements</u> . <i>Additional Inspection Procedure(s):</i> When a break-away device is present, it must be inspected according to the service instructions provided by the <u>manufacturer</u> and it must be functional.	c) <u>missing</u> from a trailer required to have a break-away device <u>damaged</u> or <u>inoperative</u>
d) battery and controller <i>Additional Inspection Procedure(s):</i> Test the battery and controller according to the service instructions provided by the <u>manufacturer</u> .	d) <u>damaged</u> or fails to <u>operate as intended</u>
	<u>Hazardous Condition(s)</u> i. brakes are <u>inoperative</u> or fail to <u>operate as intended</u> ii. required break-away device is <u>inoperative</u> or <u>missing</u>
<u>11. Brake System Indicator Lamps</u>	NOT APPLICABLE TO TRAILERS
<u>12. Drum Brake System Components</u> <i>Additional Inspection Procedure(s):</i> When an inspection reveals evidence of a defect or abnormal condition, drum disassembly is mandatory. Refer to the instructions in Section 3 when an inspection reveals <u>no evidence</u> of a defect or abnormal condition. The instructions indicate when disassembly of wheel(s) and drum(s) is optional, and what measurements are required to be taken and recorded.	
a) brake operation	a) a required brake is <u>missing</u> a brake is <u>inoperative</u>

Note: All inspection procedures are visual unless additional inspection procedures are indicated. Conditions shown **in this manner** are defined conditions. The definitions can be found in the introduction section.

ITEM AND METHOD OF INSPECTION:	REJECT IF:
<p>b) brake shoe lining condition (service brakes)</p> <p><i>Note:</i> Cracks in the surface of the lining, surface erosion and minor spalling of the contact face of the lining are normal.</p> <p>Also inspect lining for damage caused by “rust-jacking”. This includes lining material cracking, lifting or separating from backing metal, due to rust build-up.</p> <p>When the lining protrudes outside of the brake drum, drum removal is necessary to obtain lining thickness.</p>	<p>b) a crack extending partially through, or completely through the lining from the friction surface to the metal backing, passing from any rivet hole to the edge</p> <p>a crack in the edge of the lining that is wider than 1 mm or longer than 38 mm</p> <p>a piece of the lining is broken off exposing a rivet</p> <p>lining is distorted or separating from shoe, (e.g.: an object 1 mm thick can be inserted more than 10 mm between the lining and the backing metal)</p> <p>lining is contaminated by brake fluid, oil or grease (Also see section 9 item 5 for wheel seal leaks)</p> <p>lining protrudes outside of drum more than 3 mm</p> <p>lining or any lining fastener is <i>loose</i> - shim is used between lining and shoe</p> <p>shoe or lining is installed incorrectly (such as primary and secondary shoes reversed)</p>

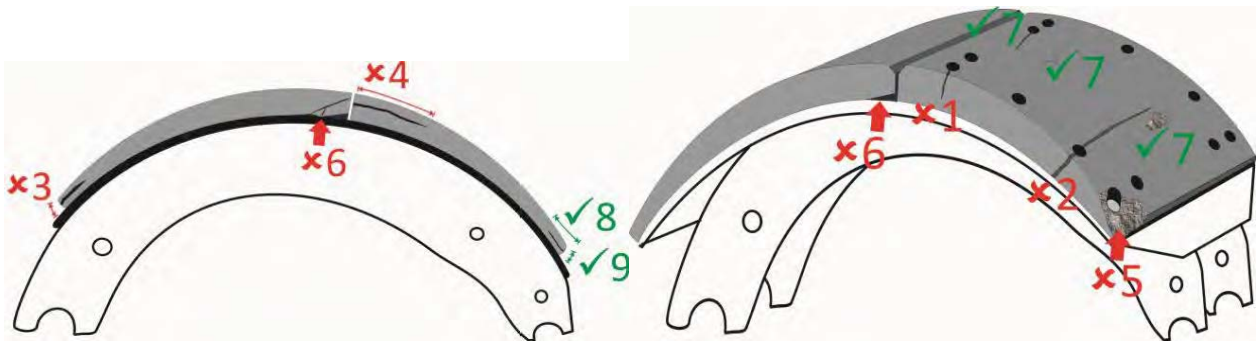

Examples of Brake Shoe Lining Pass and Reject Conditions:

- Reject condition 1 – a partial crack in the lining, extending from a rivet hole to the edge
- Reject condition 2 – a crack completely through the lining, extending from a rivet hole to the edge
- Reject condition 3 – a crack in the edge of the lining wider than 1 mm
- Reject condition 4 – a crack in the edge of the lining longer than 38 mm
- Reject condition 5 – a piece of the lining is broken off exposing a rivet
- Reject condition 6 – lining is distorted or separating from shoe
- Pass condition 7 – minor crack or spalling of the lining material
- Pass condition 8 – crack in edge of lining shorter than 38 mm
- Pass condition 9 – crack in edge of lining less than 1 mm wide

Note: All inspection procedures are visual unless additional inspection procedures are indicated. Conditions shown *in this manner* are defined conditions. The definitions can be found in the introduction section.

ITEM AND METHOD OF INSPECTION:	REJECT IF:
<p>c) brake shoe lining thickness</p> <p><i>Additional Inspection Procedure(s):</i> Lining thickness must be measured at each inspection and the measurement must be recorded on the inspection report.</p> <p><i>Note:</i> For minimum allowable thickness, lining measurements are taken at the thinnest point of the lining.</p> <p>For the purposes of recording lining thickness on the inspection report, lining thickness measurements are taken at the edge of the lining, near the centre of the brake shoe. The measurement must be taken of the thinner brake shoe lining, when there is a difference in thickness.</p>	<p>c) <u>bonded</u> brake shoe lining thickness is less than 2 mm at any point</p> <p><u>bolted or riveted</u> brake shoe lining thickness is less than 3 mm at any point <i>2 mm = 0.08 in., 3 mm = 0.12 in.</i></p>
<p>d) brake drum condition</p> <p><i>Note:</i> Heat checks and some surface cracks on the friction surface are normal.</p> <p>A <u>heat check</u> has a width less than 0.5 mm and a depth less than 0.5 mm.</p> <p>A surface crack is at least 0.5 mm wide and 0.5 mm deep.</p> <p>Any surface crack, groove or worn area that is deeper than the drum wear limit is a <u>structural weakness</u>.</p>	<p>d) surface crack longer than 75% of the width of the friction surface</p> <p>surface crack within 25 mm of the open edge</p> <p>surface crack, groove or worn area that is a structural weakness</p> <p>external crack</p> <p>friction surface is <i>abnormally worn</i>, or is hardened and blackened due to overheating (“martensite”)</p> <p>friction surface is contaminated by grease or oil (Also see section 9 item 5 for wheel seal leaks)</p>
<p>e) brake drum diameter (wear)</p> <p><i>Additional Inspection Procedure(s):</i> Brake drum diameter must be measured unless an exemption applies, and the measurement must be recorded on the inspection report. See Introduction to Section 3 for details and exceptions.</p> <p><i>Note:</i> Drum diameter measurements must be taken using a suitable tool and with the level of accuracy defined by the measurement tolerance.</p>	<p>e) measured drum diameter exceeds limit indicated on the brake drum, <i>OEM standard</i> or <i>industry standard</i>, or if limit is not available:</p> <p>for nominal drum size of 350 mm (14 in.) or less: 2.3 mm more than original drum diameter</p> <p>for nominal drum size greater than 350 mm (14 in.): 3.0 mm more than original drum diameter <i>2.3 mm = 0.09 in.</i> <i>3.0 mm = 0.12 in.</i></p>
<p>f) self-adjuster mechanism</p>	<p>f) <i>abnormally worn</i>, incorrect thread direction, <i>inoperative</i>, <i>missing</i> or seized</p>

Note: All inspection procedures are visual unless additional inspection procedures are indicated. Conditions shown ***in this manner*** are defined conditions. The definitions can be found in the introduction section.

ITEM AND METHOD OF INSPECTION:	REJECT IF:
g) anchor pin and return spring	g) <i>abnormally worn</i> , bent, broken, <i>loose</i> or <i>missing</i> spring stretched
h) backing plate	h) bent, <i>damaged</i> or <i>loose</i> shoe contact area is grooved or worn in a manner that restricts free movement of shoes
i) axle and spindle	i) cracked
j) wheel cylinder	j) <i>damaged</i> , <i>inoperative</i> or seized, <i>loose</i> or <i>insecure</i> mounting <i>level 2 leak</i> of brake fluid dust seal is cracked, <i>damaged</i> , deteriorated, <i>missing</i> , or split
k) wheel seal	k) <i>level 2 leak</i> of bearing lubricant
	<p><u>Hazardous Condition(s)</u></p> <ul style="list-style-type: none"> i. any part is binding, broken, <i>missing</i>, seized, or mounted incorrectly ii. a brake drum is in a condition where an imminent failure appears likely iii. <i>level 2 leak</i> of brake fluid at wheel cylinder iv. a brake is <i>inoperative</i> v. brake lining thickness is less than 2 mm vi. a piece of the lining is broken off exposing a rivet or bolt vii. a crack in the edge of the lining wider than 1 mm viii. a crack in the edge of the lining longer than 38 mm ix. broken or <i>missing</i> return spring, anchor pin, or spider x. brake lining or brake drum friction surface is contaminated by brake fluid, grease or oil <p>Note: Also see section 9, item 5 for wheel seal leaks</p>
<p><u>13. Disc Brake System Components</u></p>	
<p><i>Additional Inspection Procedure(s):</i> When an inspection reveals evidence of a defect or abnormal condition, wheel disassembly is mandatory.</p>	
<p>Refer to the instructions in Section 3 and <i>manufacturer</i> service instructions when an inspection reveals <u>no evidence</u> of a defect or abnormal condition. The instructions indicate when disassembly of wheel(s) is optional and what measurements are required to be taken and recorded.</p>	
a) brake operation	a) a required brake is <i>missing</i> a brake is <i>inoperative</i>

Note: All inspection procedures are visual unless additional inspection procedures are indicated. Conditions shown ***in this manner*** are defined conditions. The definitions can be found in the introduction section.

ITEM AND METHOD OF INSPECTION:	REJECT IF:
<p>b) disc (rotor) condition</p> <p><i>Note:</i> Heat checks and some surface cracks on the friction surface are normal. A heat check has a width less than 0.5 mm and a depth less than 1 mm. A surface crack is at least 0.5 mm wide <u>and</u> 1 mm deep.</p> <p><i>Note:</i> Lateral run-out and parallelism only need to be checked only where there is evidence of a problem.</p>	<p>b) section is broken off or <i>missing</i></p> <p>crack extends from the friction surface through to the cooling vent</p> <p>any surface crack is longer than 75% of the radial width, within the friction surface</p> <p>any surface crack extends to an outer edge</p> <p>groove or pitted area in rotor that reduces rotor thickness below minimum allowable value</p> <p>contact pattern of the pad on solid rotor material (i.e.: not rusted) is less than 75% of the radial width, around the entire rotor, on one side</p> <p>lateral run-out or out-of-parallelism exceeds 0.3 mm</p> <p>friction surface of the rotor is contaminated by brake fluid, grease or oil (Also see section 9 item 5 for wheel seal leaks) 0.3 mm = 0.01 in.</p>
<p>c) disc (rotor) thickness</p> <p><i>Additional Inspection Procedure(s):</i> Disc (rotor) thickness must be measured. Measurements must be recorded on inspection report.</p>	<p>c) thickness at any point across the friction surface is less than the minimum indicated on the brake rotor, <i>OEM standard</i> or <i>industry standard</i>, if limit is <u>not</u> available: less than 39.0 mm (+/- 0.05 mm)</p>
<p>d) caliper</p>	<p>d) any part is binding, broken, <i>missing</i>, seized, mounted incorrectly, or not equivalent to <i>OEM standard</i></p> <p>slide pin/slider or pad slider is binding, <i>damaged</i>, seized, mounted incorrectly, or <u>not</u> equivalent to <i>OEM standard</i></p> <p>caliper movement within the anchor plate exceeds <i>manufacturer</i> specification, guide is welded or repaired in a way that does <u>not</u> meet <i>OEM standard</i></p> <p><i>level 2 leak</i> of brake fluid</p> <p>pad retainer is bent, <i>damaged</i>, <i>insecure</i> or <i>missing</i></p> <p>boot or bellows is cracked or deteriorated, <i>damaged</i>, or <i>missing</i></p>
<p>e) anchor plate</p>	<p>e) <i>loose</i> or bolt is <i>missing</i></p>
<p>f) pad condition</p>	<p>f) broken, cracked, <i>damaged</i>, or <i>abnormally worn</i></p> <p>friction material is contaminated by brake fluid, oil or grease (Also see section 9 item 5 for wheel seal leaks)</p> <p>friction material <i>loose</i> on pad, pad is <i>missing</i>, or pad is installed incorrectly</p>

Note: All inspection procedures are visual unless additional inspection procedures are indicated. Conditions shown ***in this manner*** are defined conditions. The definitions can be found in the introduction section.

ITEM AND METHOD OF INSPECTION:	REJECT IF:
<p>g) pad (friction material) thickness</p> <p><i>Additional Inspection Procedure(s):</i> Pad (friction material) thickness of both inboard and outboard pad must be measured and measurement of the thinnest pad must be recorded on the inspection report.</p> <p><i>Note:</i> Pad (friction material) thickness can be determined by measuring the friction material itself or by measuring the combined thickness of the friction material and pad backing plate, then deducting the thickness of the backing plate. Record the thickness of the friction material only.</p>	<p>g) pad (measured friction material) thickness is less than <u>manufacturer</u> specification, or <u>industry standard</u>, or if limit is not available:</p> <ul style="list-style-type: none"> • bonded friction material thickness is less than 3 mm • riveted friction material thickness is less than 5 mm • difference between inboard and outboard friction material thickness is greater than <u>OEM standard</u> or <u>industry standard</u>, or if limit is <u>not</u> available: difference is greater than 3 mm <p><i>3 mm = 0.12 in., 5 mm = 0.20 in.</i></p>
<p>h) clearance between pads and rotor (caliper adjustment)</p>	<p>h) does <u>not</u> meet <u>manufacturer's</u> specifications</p>
	<p><u>Hazardous Condition(s)</u></p> <ul style="list-style-type: none"> i. any part is binding, broken, <u>missing</u>, seized or mounted incorrectly ii. a rotor (disc) friction surface shows metal to metal contact with brake pad or severe rusting iii. a rotor (disc) has a crack that extends to the hub or through to the vented section iv. caliper movement within the anchor plate exceeds 3 mm v. any brake component is in a condition where an imminent failure appears likely vi. a brake is <u>inoperative</u> vii. brake pad friction material is worn to less than 2 mm viii. friction material of the pad or friction surface of the rotor is contaminated by brake fluid, grease or oil <p><i>Note: Also see section 9 item 5 for wheel seal leaks.</i></p>
<p><u>14. Mechanical Parking Brake</u></p>	<p>NOT APPLICABLE TO TRAILERS</p>
<p><u>15. Spring-Applied Air-Released (SAAR) Parking Brake</u></p>	<p>NOT APPLICABLE TO TRAILERS</p>
<p><u>16. Spring-Applied Hydraulic-Released (SAHR) Parking Brake</u></p>	<p>NOT APPLICABLE TO TRAILERS</p>
<p><u>17. Anti-Lock Brake System (ABS) on a Truck or Bus</u></p>	<p>NOT APPLICABLE TO TRAILERS</p>
<p><u>18. Stability Control System</u></p>	<p>NOT APPLICABLE TO TRAILERS</p>

Note: All inspection procedures are visual unless additional inspection procedures are indicated. Conditions shown in this manner are defined conditions. The definitions can be found in the introduction section.

ITEM AND METHOD OF INSPECTION:	REJECT IF:
<p>19. Brake Performance</p> <p><i>Optional Additional Inspection Procedure(s):</i> These test methods can be used when one of the following types of performance-based brake tester (PBBT) is available. Test equipment must be calibrated and used according to <u>manufacturer</u> instructions.</p> <p>Testing a brake with non-burnished friction material may produce inconsistent test results.</p>	<p><i>Note:</i> Rated wheel weight = one-half of GAWR.</p>
<p>a) service brake force – using a roller-type performance-based brake tester (PBBT)</p> <p><i>Optional Additional Inspection Procedure(s):</i> Determine the maximum service brake force at each wheel by slowly applying the service brake pedal and increasing the pedal force until the tester terminates the test, or brake force reaches its maximum value.</p>	<p>a) service brake fails to lock the wheel <u>and</u> the maximum service brake force is less than 40% of the rated wheel weight</p> <p>service brake force on one side of the axle is less than 70% of the service brake force on the other side, at the point in time just prior to first wheel lockup, or test termination, whichever occurs first</p>
<p>b) rolling resistance force – using a roller-type performance-based brake tester (PBBT)</p> <p><i>Optional Additional Inspection Procedure(s):</i> Determine average rolling resistance force of each wheel, with the brakes fully released, for one full revolution of the wheel. Discount the initial spike at start-up of the rolls.</p>	<p>b) average rolling resistance force of a wheel is greater than 6% of the weight of the wheel imparted on the test device</p>
<p>c) required brake force or stopping distance – using a decelerometer</p> <p><i>Optional Additional Inspection Procedure(s):</i> Test vehicle stopping ability in a suitable area following the instructions provided by the manufacturer/supplier of the test device.</p>	<p>c) deceleration is below the requirement of the relevant jurisdiction</p> <p>balance of brake force between left and right side fails to comply with the requirement of the relevant jurisdiction</p> <p><i>Note:</i> Brake force balance (left and right) cannot be measured with all types of decelerometers.</p>

Note: All inspection procedures are visual unless additional inspection procedures are indicated. Conditions shown in this manner are defined conditions. The definitions can be found in the introduction section.

Section 3A – Air Brakes

ITEM AND METHOD OF INSPECTION:	REJECT IF:
<p><i>Note:</i> Inspect Air System at Normal Operating Pressure - Unless noted otherwise below, all operational checks of air brake system components are conducted with the system at its normal operating pressure (between compressor cut-in and cut-out values).</p> <p><u>OEM Vehicle Gauge Accuracy</u> - The gauges on a vehicle's instrument panel showing pressure in the airbrake system are required to be accurate within plus or minus 7% of the compressor cut-out pressure.</p> <p>Use Accurate Test Gauge - When there is any doubt about any test or inspection results obtained, use of a gauge accurate to +/- 2% to confirm pressure values is recommended.</p>	
<p><u>1. Air Compressor</u></p>	<p>NOT APPLICABLE TO TRAILERS</p>
<p><u>2. Air Supply System</u></p>	<p>NOT APPLICABLE TO TRAILERS</p>
<p><u>3. Air System Leakage on a Trailer</u></p>	
<p>a) air leakage</p> <p><i>Additional Inspection Procedure(s):</i> Monitor the system for leaks during the inspection by listening for leaks.</p>	<p>a) detectable leak at any location</p>
<p>b) air loss rate</p> <p><i>Additional Inspection Procedure(s):</i> Step 1. Fill the supply circuit to normal operating pressure. Shut off the air supply and seal the circuit while monitoring air pressure.</p> <p>Step 2. While keeping the supply circuit filled, also fill the service circuit to the same pressure. Shut off the air supply and seal the circuits while monitoring air pressure.</p> <p>Step 3. Supply air to all other air systems and/or accessory devices. Shut off the air supply and seal the circuits while monitoring air pressure.</p>	<p>b) trailer is attached to a towing vehicle and total leakage exceeds 28 kPa (4 psi) in one minute</p> <p>trailer is connected to non-vehicle air source and total leakage exceeds 20 kPa (3 psi) in one minute</p>
	<p><u>Hazardous Condition(s)</u></p> <p>i. air pressure drops more than 40 kPa +/- 5 kPa (6 psi) per minute during air leakage test</p>

Note: All inspection procedures are visual unless additional inspection procedures are indicated. Conditions shown *in this manner* are defined conditions. The definitions can be found in the introduction section.

ITEM AND METHOD OF INSPECTION:	REJECT IF:
4. Air Tank	
a) contamination <i>Additional Inspection Procedure(s):</i> Open the drain valve on each tank and drain all fluid.	a) the quantity of oil or sludge, (i.e.: oil and water mixture) expelled from an air tank exceeds manufacturer service recommendations **the quantity of water expelled from an air tank exceeds <i>manufacturer</i> service recommendations
	<i>Note:</i> **Record excessive water on the inspection report, but do not reject the vehicle for this condition alone.
b) air tank condition	b) corroded or <i>damaged</i> to the extent that structural integrity is compromised, leaking or <i>loose</i> welding other than original factory weld on air tank tank does <i>not</i> meet <i>OEM standard</i>
c) air tank bracket and/or strap	c) broken, cracked or <i>missing</i> does <i>not</i> meet <i>OEM standard</i>
d) air tank drain valve	d) <i>inoperative</i> , leaking, <i>loose</i> or <i>missing</i> does <i>not</i> meet <i>OEM standard</i>
e) moisture ejector	e) <i>inoperative</i> , leaking
	<u>Hazardous Condition(s)</u> i. air tank is <i>loose</i>, allowing movement of more than 25 mm in any direction
5. Air Tank Check Valves	NOT APPLICABLE TO TRAILERS

Note: All inspection procedures are visual unless additional inspection procedures are indicated. Conditions shown ***in this manner*** are defined conditions. The definitions can be found in the introduction section.

ITEM AND METHOD OF INSPECTION:	REJECT IF:
<u>6. Brake Pedal/Actuator</u>	NOT APPLICABLE TO TRAILERS
<u>7. Treadle Valve and Trailer Hand Valve</u>	NOT APPLICABLE TO TRAILERS
<u>8. Brake Valves & Controls</u>	
a) operation <i>Additional Inspection Procedure(s):</i> Test the operation of all valves and controls.	a) any valve is <i>inoperative</i>
b) condition <i>Additional Inspection Procedure(s):</i> Check the condition and security of all air brake system components.	b) broken, <i>damaged</i> , repaired in a way that does <u>not</u> meet <i>OEM standard</i> <i>loose, insecure</i> mounting, mounting bracket or mounting fastener <i>damaged</i> , stripped or <i>missing</i>
c) quick release valve, relay valve <i>Note:</i> It is important that any repair or replacement of a brake valve retains brake functionality according to original <i>OEM</i> design. <i>Additional Inspection Procedure(s):</i> Apply and release the service brakes and check system operation. Check for signs of improper installation or replacement of the wrong type of valve. <i>Note:</i> It is important that the inspector be familiar with the design and operating requirements of the vehicle being inspected. This is a visual inspection only.	c) <i>inoperative</i> , air is not released quickly through exhaust port when brakes are released air leaks from valve back into the system an improper valve is visually identified
d) air system or accessory device, (e.g.: suspension, tire inflation system, pintle hook damper, tail gate, landing gear, tarp system, etc.) <i>Note:</i> The pressure protection valve must be installed so that it prevents a failure in such a system or accessory from depleting all of the pressure from the brake system.	d) any system or accessory device that draws air from the air brake system is not equipped with a functioning pressure protection valve
	<u>Hazardous Condition(s)</u> i. quick release valve or relay valve is <i>inoperative</i> or <i>missing</i>
<u>9. Proportioning, Inversion or Modulating Valve</u>	NOT APPLICABLE TO TRAILERS
<u>10. Towing Vehicle (Tractor) Protection System</u>	NOT APPLICABLE TO TRAILERS
<u>11. Parking Brake and Emergency Application on Truck or Bus</u>	NOT APPLICABLE TO TRAILERS

Note: All inspection procedures are visual unless additional inspection procedures are indicated. Conditions shown ***in this manner*** are defined conditions. The definitions can be found in the introduction section.

ITEM AND METHOD OF INSPECTION:	REJECT IF:
<u>12. Parking Brake and Emergency Application on Trailer</u>	
a) parking brake application <i>Additional Inspection Procedure(s):</i> Actuate the parking brake control as required. Check parking brake function at each wheel.	a) brake does <u>not</u> apply on any wheel required to have parking brake
b) parking brake release	b) parking brake releases slowly, hangs or drags
c) emergency application <i>Additional Inspection Procedure(s):</i> Actuate emergency application of the parking brakes by exhausting the trailer supply/emergency line, using the trailer supply valve, by removing the gladhand, or by using a suitable test device.	c) parking brakes do not immediately apply automatically time required for air pressure in the chambers to fall to atmospheric pressure is more than 3 seconds <i>Note:</i> For this test, atmospheric pressure is considered 21 kPa (3 psi) or less.
<u>Hazardous Condition(s)</u> i. parking brake does not <i>operate as intended</i>	
<u>13. Air System Components</u>	
a) gladhand	a) corroded or <i>insecure</i> mounting, cracked or <i>damaged</i> seal <i>damaged</i> or <i>missing</i>
b) gladhand screen	b) plugged or ruptured
c) air line, connection and fitting <i>Note:</i> Improper installation, repairs and modifications can negatively affect brake operation, and particularly brake timing. Improper use of fittings, additional elbows, and replacing an air line with one that is too small, are examples of improper procedures. <i>Additional Inspection Procedure(s):</i> Check for improper installations, modifications or repairs.	c) fitting, line, repair method, installation or modification does <u>not</u> meet <i>industry standard</i> or <i>OEM standard</i> tubing or hose is defective as defined in the chart on page 5 fitting or connection is broken, cracked, flattened or leaking <i>damaged</i> in a way (such as: melting, flattening, deformation or kinking) that can restrict air flow
d) air system or accessory device, (e.g. suspension, tire inflation system, pintle hook damper, tail gate, landing gear, tarp system) <i>Additional Inspection Procedure(s):</i> Visually inspect for presence of correct type of valve.	d) any system or accessory device that draws air from the air brake system is <u>not</u> equipped with a functioning pressure protection valve
e) leakage <i>Additional Inspection Procedure(s):</i> Monitor system for leaks.	e) an air leak at any location

Note: All inspection procedures are visual unless additional inspection procedures are indicated. Conditions shown *in this manner* are defined conditions. The definitions can be found in the introduction section.

ITEM AND METHOD OF INSPECTION:	REJECT IF:
	<p><u>Hazardous Condition(s)</u></p> <ul style="list-style-type: none"> i. an air line bulges under pressure ii. air line modification or repair does not meet <i>industry standard</i> or <i>OEM standard</i> iii. air line has damage extending through the outer reinforcement ply iv. an inner layer of an air line is exposed due to abrasion or rubbing v. air leak at other than a proper connection vi. air line is <i>damaged</i> by heat, broken, or crimped in such a manner as to restrict airflow
<p><u>14. Brake Chamber</u></p>	
<p>a) brake chamber</p>	<p>a) improper type or size brake chamber is used</p> <p>corroded, cracked, <i>damaged</i>, <i>insecure</i> mounting, <i>loose</i>, <i>missing</i>, or leaking</p> <p>drain hole is <u>not</u> directed downward or is plugged</p> <p>mixed long-stroke and standard stroke chambers on an axle</p> <p>mismatched chamber size on an axle</p> <p>piston return spring is broken or binding</p>
<p>b) spring brake chamber</p>	<p>b) park brake-apply spring is caged by caging bolt or made <i>inoperative</i> by other mechanical means</p> <p>chamber caging plate is misaligned or hung up preventing installation of caging bolt</p> <p>park brake-apply spring is broken</p>
<p>c) chamber mounting bracket</p>	<p>c) broken, cracked, deformed, <i>loose</i> or <i>missing</i></p>
<p>d) type DD3 chamber</p> <p><i>Additional Inspection Procedure(s):</i> Apply the parking brake and deplete system pressure starting with the supply (wet) tank.</p>	<p>d) brake <u>fails to</u> remain fully applied at any wheel with Type DD3 chamber</p>
	<p><u>Hazardous Condition(s)</u></p> <ul style="list-style-type: none"> i. air leak at a chamber ii. caging plate in a chamber is out of position or ‘hung up’ iii. non-manufactured hole or crack in a chamber iv. <i>insecure</i>, <i>loose</i> or <i>missing</i> chamber v. mismatched chamber type or size on active or passive steer axle vi. improper type or size brake chamber is used on a steer axle

Note: All inspection procedures are visual unless additional inspection procedures are indicated. Conditions shown *in this manner* are defined conditions. The definitions can be found in the introduction section.

ITEM AND METHOD OF INSPECTION:	REJECT IF:
<p><u>15. Drum Brake System Components</u></p> <p><i>Additional Inspection Procedure(s):</i> When an inspection reveals evidence of a defect or abnormal condition, disassembly of wheel(s) and drum(s) is mandatory.</p> <p>Refer to the instructions in Section 3 when an inspection reveals <u>no evidence</u> of a defect or abnormal condition. The instructions indicate when disassembly of wheel(s) and drum(s) is optional, and what measurements are required to be taken and recorded.</p>	
<p>a) brake operation</p>	<p>a) a required brake is <i>missing</i> a brake is <i>inoperative</i></p>
<p>b) brake shoe lining condition (service brakes)</p> <p><i>Note:</i> Cracks in the surface of the lining, surface erosion and minor spalling of the contact face of the lining are normal.</p> <p>Also inspect lining for damage caused by “rust-jacking”. This includes lining material cracking, lifting or separating from backing metal, due to rust build- up.</p> <p>When the lining protrudes outside of the brake drum, drum removal is necessary to obtain lining thickness.</p>	<p>b) a crack extending partially through, or completely through the lining from the friction surface to the metal backing, passing from any rivet hole to the edge</p> <p>a crack in the edge of the lining that is wider than 1 mm or longer than 38 mm</p> <p>a piece of the lining is broken off exposing a rivet or bolt</p> <p>lining is distorted or separating from shoe, (e.g.: an object 1 mm thick can be inserted more than 10 mm between the lining and the backing metal)</p> <p>lining is contaminated by oil or grease (Also see section 9 item 5 for wheel seal leaks)</p> <p>lining protrudes outside of drum more than 3 mm</p> <p>lining or any lining fastener is <i>loose</i></p> <p>shim is used between lining and shoe</p> <p>shoe or lining is installed incorrectly (such as primary and secondary shoes reversed)</p>

Note: All inspection procedures are visual unless additional inspection procedures are indicated. Conditions shown ***in this manner*** are defined conditions. The definitions can be found in the introduction section.

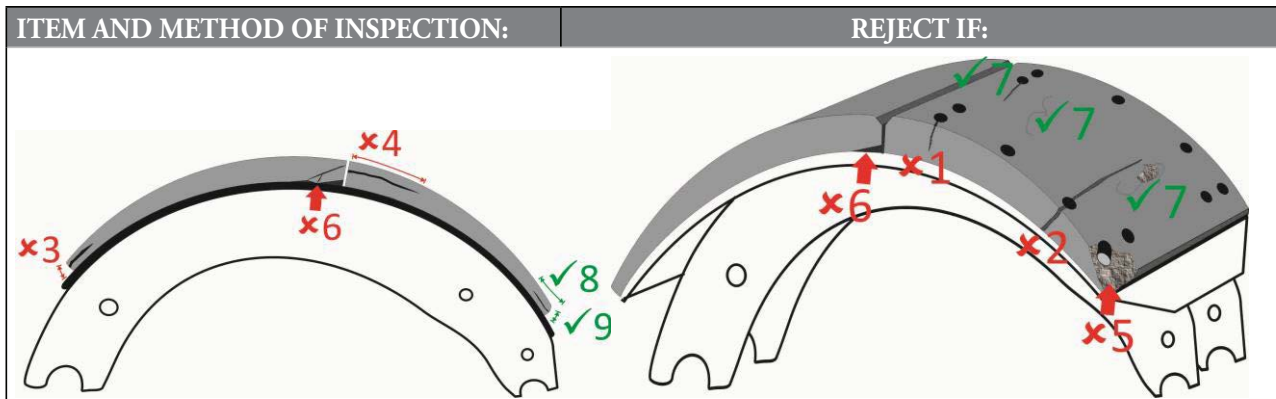

Examples of Brake Shoe Lining Pass and Reject Conditions:

- Reject condition 1 – a partial crack in the lining, extending from a rivet hole to the edge
- Reject condition 2 – a crack completely through the lining, extending from a rivet hole to the edge
- Reject condition 3 – a crack in the edge of the lining wider than 1 mm
- Reject condition 4 – a crack in the edge of the lining longer than 38 mm
- Reject condition 5 – a piece of the lining is broken off exposing a rivet
- Reject condition 6 – lining is distorted or separating from shoe
- Pass condition 7 – minor crack or spalling of the lining material
- Pass condition 8 – crack in edge of lining shorter than 38 mm
- Pass condition 9 – crack in edge of lining less than 1 mm wide

c) brake shoe lining thickness

Additional Inspection Procedure(s):

Lining thickness must be measured at each inspection and the measurement must be recorded on the inspection report.

Note:

For minimum allowable thickness, lining measurements are taken at the thinnest point of the lining.

For the purposes of recording lining thickness on the inspection report, lining thickness measurements are taken at the edge of the lining, near the centre of the brake shoe. The measurement must be taken of the thinner brake shoe lining, when there is a difference in thickness.

c) bonded or riveted continuous strip brake shoe lining thickness is less than 5 mm at any point

bolted or riveted block type brake shoe lining thickness is less than 8 mm at any point
 8 mm = 0.3 (5/16) in., 5 mm = 0.2 (3/16) in.

Note: All inspection procedures are visual unless additional inspection procedures are indicated. Conditions shown *in this manner* are defined conditions. The definitions can be found in the introduction section.

ITEM AND METHOD OF INSPECTION:	REJECT IF:
<p>d) brake drum condition</p> <p><i>Note:</i> Heat checks and some surface cracks on the friction surface are normal.</p> <p>A <u>heat check</u> has a width less than 0.5 mm and a depth less than 0.5 mm.</p> <p>A <u>surface crack</u> is at least 0.5 mm wide and 0.5 mm deep.</p> <p>Any surface crack, groove or worn area that is deeper than the drum wear limit is a <u>structural weakness</u>.</p>	<p>d) surface crack longer than 75% of the width of the friction surface</p> <p>surface crack within 25 mm of the open edge</p> <p>surface crack, groove or worn area that is a structural weakness</p> <p>external crack</p> <p>friction surface is <i>abnormally worn</i>, or is hardened and blackened due to overheating (“martensite”)</p> <p>friction surface is contaminated by grease or oil (Also see section 9 item 5 for wheel seal leaks)</p>
<p>e) brake drum diameter (wear)</p> <p><i>Additional Inspection Procedure(s):</i> Brake drum diameter must be measured at most inspections and the measurement must be recorded on the inspection report. See Introduction to Section 3A for details and exceptions.</p> <p><i>Note:</i> Drum diameter measurements must be taken using a suitable tool and with the level of accuracy defined by the measurement tolerance.</p>	<p>e) measured drum diameter exceeds limit indicated on the brake drum, <i>OEM standard</i> or <i>industry standard</i>, or if limit is not available:</p> <ul style="list-style-type: none"> • for nominal drum size of 350 mm (14 in) or less: 2.3 mm more than original drum diameter • for nominal drum size greater than 350 mm (14 in): 3.0 mm more than original drum diameter 2.3 mm = 0.09 in., 3 mm = 0.12 in.
<p>f) wheel seal</p>	<p>f) <i>level 2 leak</i> of bearing lubricant</p>
<p>g) return spring</p>	<p>g) <i>missing</i>, broken or stretched (fails to hold both rollers against cam)</p>
<p>h) spider</p>	<p>h) bent, broken, <i>loose</i>, welded or repaired in a way that does <u>not</u> meet <i>OEM standard</i></p> <p>mounting bolt <i>missing</i></p>

Note: All inspection procedures are visual unless additional inspection procedures are indicated. Conditions shown ***in this manner*** are defined conditions. The definitions can be found in the introduction section.

ITEM AND METHOD OF INSPECTION:	REJECT IF:
	<p><u>Hazardous Condition(s)</u></p> <ul style="list-style-type: none"> i. any part is binding, broken, <i>missing</i>, seized, or mounted incorrectly ii. a brake drum is in a condition where an imminent failure appears likely iii. a brake is <i>inoperative</i> iv. bonded or riveted continuous strip brake shoe lining thickness is less than 5 mm at centre of shoe v. bolted or riveted block type brake shoe lining thickness is less than 7 mm, at centre of shoe vi. brake shoe lining is less than 1 mm at any point vii. a piece of the lining is broken off exposing a rivet or bolt viii. a crack in the edge of the lining wider than 1 mm ix. a crack in the edge of the lining longer than 38 mm x. broken or missing return spring, anchor pin, or spider xi. brake lining or drum friction surface is contaminated by grease or oil <p><i>Note: Also see section 9 item 5 for wheel seal leaks</i> 5 mm = 0.2 (3/16) in., 7 mm = 0.25 in. (1/4) in.</p>
<p><u>16. S-Cam Drum Brake System</u></p> <p><i>Note:</i> Also applies to T-Cam brake system.</p>	
<p>a) camshaft condition</p> <p><i>Additional Inspection Procedure(s):</i> Check the condition and mounting of each brake camshaft, and check for movement in the bushings.</p>	<p>a) camshaft is bent, twisted, repaired by welding, incorrectly installed or incorrect type</p> <p>movement of camshaft in bushing exceeds 2.0 mm</p>
<p>b) camshaft mounting</p> <p>c) pushrod, clevis yoke, clevis pin and locking device</p> <p><i>Note:</i> Brake pushrod stroke indicators are required by CMVSS 121 on vehicles manufactured on and after May 31, 1996. These indicators normally consist of markings on the brake chamber pushrod, but can also be mounted on, or adjacent to, the brake linkage. They must be capable of showing an over- stroke condition.</p>	<p>b) mounting bracket broken or <i>loose</i></p> <p>c) bent, binding, broken, cracked, <i>missing</i>, welded or repaired in a way that does <u>not</u> meet <i>OEM standard</i></p> <p>clevis yoke lock nut is <i>loose</i></p> <p>linkage is misaligned to slack adjuster or brake chamber</p> <p>does <u>not</u> form correct angle with slack adjuster when brakes are applied</p> <p>brake stroke indicator is <i>missing</i></p>

Note: All inspection procedures are visual unless additional inspection procedures are indicated. Conditions shown ***in this manner*** are defined conditions. The definitions can be found in the introduction section.

ITEM AND METHOD OF INSPECTION:	REJECT IF:
<p>d) brake adjuster</p> <p><i>Note:</i> Self-adjusting brake adjusters are required by CMVSS 121 on vehicles manufactured on and after May 31, 1996. They cannot be replaced with manual brake adjusters.</p>	<p>d) <u>not</u> equipped with self-adjuster as required</p> <p>adjuster is <i>inoperative</i> or improperly installed</p> <p>improper type or size brake adjuster is used</p> <p>any part is bent, broken or <i>abnormally worn</i></p> <p>the self-locking sleeve on a manual slack adjuster is seized or fails to lock</p>
<p>e) slack adjuster effective length</p>	<p>e) the distance from the centre of a camshaft to the centre of the clevis pin is <u>not</u> the same on all brakes of an axle</p>
<p>f) brake shoe roller</p>	<p>f) flat spots, <i>missing</i>, wrong size</p>
<p>g) brake shoe anchor pin</p>	<p>g) <i>missing</i>, wear allows the lining to protrude beyond outside edge of brake drum</p>
<p>h) brake stroke</p> <p><i>Additional Inspection Procedure(s):</i> Measure and record the applied push rod stroke of each brake with 620 to 690 kPa (90 to 100 psi) in the air tanks, the spring brakes released, the engine shut off and service brakes fully applied.</p> <p><i>Note:</i> The stroke measurements of all brakes are to be recorded on the inspection report.</p> <p>When the stroke of a self-adjusting brake adjuster is found to be at or beyond the stroke limit, the brake requires repairs. A manual adjustment will not correct the problem.</p>	<p>h) stroke is at or beyond the limit of the brake chamber as shown in the chart below</p> <p>difference between stroke measurements is greater than 6 mm on an axle</p>
	<p><u>Hazardous Condition(s)</u></p> <ul style="list-style-type: none"> i. camshaft is incorrectly installed, incorrect type, or mounting is <i>insecure</i> ii. improper type or size camshaft roller is used iii. improper type or size brake adjuster is used on a steer axle iv. broken or missing cam roller, camshaft, pushrod, yoke, clevis pin, clevis pin retainer, (e.g., cotter pin), v. stroke of any brake is beyond the limit of the brake chamber as shown in the chart below

Note: All inspection procedures are visual unless additional inspection procedures are indicated. Conditions shown ***in this manner*** are defined conditions. The definitions can be found in the introduction section.

ITEM AND METHOD OF INSPECTION:	REJECT IF:																																													
<p><u>Brake Stroke Limits for Clamp-Type Brake Chambers</u></p> <p><i>Note:</i> Measurement tolerance is +/- 1 mm</p> <table border="1"> <thead> <tr> <th>Chamber Type (Size)</th> <th>Stroke Limit (mm)</th> <th>Stroke Limit (in.) +/- 1/32 in.</th> </tr> </thead> <tbody> <tr><td>6</td><td>32 mm</td><td>1- 1/4 in.</td></tr> <tr><td>9</td><td>35 mm</td><td>1 -3/8 in.</td></tr> <tr><td>12</td><td>35 mm</td><td>1 -3/8 in.</td></tr> <tr><td>12 LS</td><td>44 mm</td><td>1 -3/4 in.</td></tr> <tr><td>16</td><td>44 mm</td><td>1- 3/4 in.</td></tr> <tr><td>16 LS</td><td>51 mm</td><td>2 in.</td></tr> <tr><td>20</td><td>44 mm</td><td>1-3/4 in.</td></tr> <tr><td>20 LS</td><td>51 mm</td><td>2 in.</td></tr> <tr><td>24</td><td>44 mm</td><td>1-3/4 in.</td></tr> <tr><td>24 LS</td><td>51 mm</td><td>2 in.</td></tr> <tr><td>30</td><td>51 mm</td><td>2 in.</td></tr> <tr><td>30 LS</td><td>64 mm</td><td>2-1/2 in.</td></tr> <tr><td>30 DD3</td><td>57 mm</td><td>2-1/4 in.</td></tr> <tr><td>36</td><td>57 mm</td><td>2-1/4 in.</td></tr> </tbody> </table>		Chamber Type (Size)	Stroke Limit (mm)	Stroke Limit (in.) +/- 1/32 in.	6	32 mm	1- 1/4 in.	9	35 mm	1 -3/8 in.	12	35 mm	1 -3/8 in.	12 LS	44 mm	1 -3/4 in.	16	44 mm	1- 3/4 in.	16 LS	51 mm	2 in.	20	44 mm	1-3/4 in.	20 LS	51 mm	2 in.	24	44 mm	1-3/4 in.	24 LS	51 mm	2 in.	30	51 mm	2 in.	30 LS	64 mm	2-1/2 in.	30 DD3	57 mm	2-1/4 in.	36	57 mm	2-1/4 in.
Chamber Type (Size)	Stroke Limit (mm)	Stroke Limit (in.) +/- 1/32 in.																																												
6	32 mm	1- 1/4 in.																																												
9	35 mm	1 -3/8 in.																																												
12	35 mm	1 -3/8 in.																																												
12 LS	44 mm	1 -3/4 in.																																												
16	44 mm	1- 3/4 in.																																												
16 LS	51 mm	2 in.																																												
20	44 mm	1-3/4 in.																																												
20 LS	51 mm	2 in.																																												
24	44 mm	1-3/4 in.																																												
24 LS	51 mm	2 in.																																												
30	51 mm	2 in.																																												
30 LS	64 mm	2-1/2 in.																																												
30 DD3	57 mm	2-1/4 in.																																												
36	57 mm	2-1/4 in.																																												
<p><u>17. Brake Shoe Travel (Wedge Brakes)</u></p> <p>a) brake shoe movement</p> <p><i>Additional Inspection Procedure(s):</i> Inspect wedge brakes according to item 15 above and then check brake operation and measure shoe movement.</p> <p>Brake shoe movement must be measured and measurements must be recorded on the inspection report.</p>	<p>a) brakes fail to operate, shoes do <u>not</u> move or shoe movement exceeds 2 mm</p>																																													
	<p><u>Hazardous Condition(s)</u></p> <p>i. shoe movement is greater than 2 mm</p> <p>ii. any wedge brake is <i>inoperative</i></p>																																													

Note: All inspection procedures are visual unless additional inspection procedures are indicated. Conditions shown *in this manner* are defined conditions. The definitions can be found in the introduction section.

ITEM AND METHOD OF INSPECTION:	REJECT IF:
<p><u>18. Disc Brake System Components</u></p> <p><i>Additional Inspection Procedure(s):</i> When an inspection reveals evidence of a defect or abnormal condition, wheel disassembly is mandatory.</p> <p>Refer to the instructions in Section 3 and <i>manufacturer</i> service instructions when an inspection reveals <i>no evidence</i> of a defect or abnormal condition. The instructions indicate when disassembly of wheel(s) is optional and what measurements are required to be taken and recorded.</p>	
<p>a) brake operation</p>	<p>a) a required brake is <i>missing</i> a brake is <i>inoperative</i></p>
<p>b) disc (rotor) condition</p> <p><i>Note:</i> Heat checks and some surface cracks on the friction surface are normal. A heat check has a width less than 0.5 mm and a depth less than 1 mm. A surface cracks is at least 0.5 mm wide <i>and</i> 1 mm deep.</p> <p><i>Note:</i> Lateral run-out and parallelism only need to be checked only where there is evidence of a problem.</p>	<p>b) section is broken off or missing</p> <p>crack extends from the friction surface through to the cooling vent</p> <p>any surface crack is longer than 75% of the radial width, within the friction surface</p> <p>any surface crack extends to an outer edge</p> <p>groove or pitted area in rotor that reduces rotor thickness below minimum allowable value</p> <p>contact pattern of the pad on solid rotor material, (i.e.: not rusted) is less than 75% of the radial width, around the entire rotor, on one side</p> <p>lateral run-out or out-of-parallelism exceeds 0.3 mm</p> <p>friction surface of the rotor is contaminated by grease or oil (Also see section 9 item 5 for wheel seal leaks) 0.3 mm = 0.01 in.</p>
<p>c) disc (rotor) thickness</p> <p><i>Additional Inspection Procedure(s):</i> Disc (rotor) thickness must be measured. Measurements must be recorded on inspection report.</p>	<p>c) thickness at any point across the friction surface is less than the minimum indicated on the brake rotor, or <i>manufacturer</i> specification, or equivalent industry standard, if limit is <i>not</i> available: less than 39.0 mm (+/- 0.05 mm)</p>

Note: All inspection procedures are visual unless additional inspection procedures are indicated. Conditions shown ***in this manner*** are defined conditions. The definitions can be found in the introduction section.

ITEM AND METHOD OF INSPECTION:	REJECT IF:
d) caliper	<p>d) any part is binding, broken, missing, seized, mounted incorrectly, or <u>not</u> equivalent to <i>OEM standard</i></p> <p>slide pin/slider or pad slider is binding, <i>damaged</i>, seized, mounted insecurely, or <u>not</u> equivalent to <i>OEM standard</i></p> <p>caliper movement within the anchor plate exceeds <i>manufacturer</i> specification, guide is welded or repaired in a way that does <u>not</u> meet <i>OEM standard</i></p> <p>pad retainer is bent, <i>damaged</i>, <i>insecure</i> or <i>missing</i></p> <p>boot or bellows is cracked or deteriorated, <i>damaged</i>, or <i>missing</i></p>
e) anchor plate	e) <i>loose</i> or bolt is <i>missing</i>
f) pad condition	<p>f) broken, cracked, <i>damaged</i>, or <i>abnormally worn</i></p> <p>friction material is contaminated by oil or grease (Also see section 9 item 5 for wheel seal leaks)</p> <p>rivet <i>loose</i> on pad, pad <i>loose</i> on bonded lining, pad is <i>missing</i>, or pad is installed incorrectly</p>
<p>g) pad (friction material) thickness</p> <p><i>Additional Inspection Procedure(s):</i> Pad (friction material) thickness of both inboard and outboard pad must be measured and measurement of the thinnest pad must be recorded on the inspection report.</p> <p><i>Note:</i> Pad (friction material) thickness can be determined by measuring the friction material itself or by measuring the combined thickness of the friction material and pad backing plate, then deducting the thickness of the backing plate. Always record the thickness of the friction material only.</p>	<p>g) <i>measured friction material thickness is less than OEM standard or industry standard, or if limit is not available:</i></p> <p>bonded friction material thickness is less than 3 mm</p> <p>riveted friction material thickness is less than 5 mm</p> <p>difference between inboard and outboard friction material thickness is greater than amount indicated in <i>manufacturer</i> service instruction or equivalent industry standard, or if limit is not available: difference is greater than 3 mm 3 mm = 0.12 (1/8) in., 5 mm = 0.20 (3/16) in.</p>
h) clearance between pads and rotor (caliper adjustment)	h) does <u>not</u> meet <i>manufacturer</i> specifications

Note: All inspection procedures are visual unless additional inspection procedures are indicated. Conditions shown ***in this manner*** are defined conditions. The definitions can be found in the introduction section.

ITEM AND METHOD OF INSPECTION:	REJECT IF:
	<p><u>Hazardous Condition(s)</u></p> <ul style="list-style-type: none"> i. any part is binding, broken, <i>missing</i>, seized, or mounted incorrectly ii. a rotor (disc) friction surface shows metal to metal contact with brake pad or severe rusting iii. a rotor (disc) has a crack that extends to the hub or through to the vented section iv. caliper movement within the anchor plate exceeds 3 mm v. any brake component is in a condition where an imminent failure appears likely vi. a brake is <i>inoperative</i> vii. brake pad friction material worn to less than 2 mm or a portion of the friction material is <i>missing</i> viii. <i>loose</i> or <i>missing</i> brake chamber or caliper mounting bolt ix. friction material of the pad or friction surface of the rotor is contaminated by grease or oil <p><i>Note: Also see section 9 item 5 for wheel seal leaks 2 mm = 0.08 in., 3 mm = 0.12 (1/8) in.</i></p>
<p><u>19. Anti-Lock Brake System (ABS) on Truck and Bus</u></p>	<p>NOT APPLICABLE TO TRAILERS</p>
<p><u>20. Anti-Lock Brake System (ABS) on Trailer</u></p> <p><i>Note:</i> Every trailer with air brakes manufactured on or after April 1, 2000 must be equipped with ABS. *(see exceptions below)</p> <p>Every vehicle equipped with ABS that was not mandatory for the vehicle when it was manufactured including those listed in the exceptions below must have ABS in good working order.</p>	

Note: All inspection procedures are visual unless additional inspection procedures are indicated. Conditions shown *in this manner* are defined conditions. The definitions can be found in the introduction section.

ITEM AND METHOD OF INSPECTION:	REJECT IF:
<p>a) indicator lamp (trailer-mounted)</p> <p><i>Additional Inspection Procedure(s):</i> Proper operation of the ABS must be confirmed using one of the methods listed below:</p> <p>Test Method #1. Connect to towing vehicle manufactured after March 1, 2001 that has been verified to have a properly functioning ABS.</p> <p>Test Method #2. Using suitable test equipment, confirm that trailer ABS control module sends required signal to operate dash mounted ABS lamp in towing vehicle.</p> <p>* <i>Exceptions for ABS</i> ABS is not required by <u>CMVSS</u> 121 for: trailers with width greater than 2.6 m, any vehicle equipped with an axle that has a GVWR greater than 13,154 kg; GVWR greater than 54,332 kg – “heavy hauler trailer”; and any load divider dolly.</p>	<p>a) <i>missing</i>, not amber in colour</p> <p>is <u>not</u> marked “ABS” on the lamp itself, or not marked “ABS” within 150 mm of the lamp</p> <p>is <u>not</u> between 150 mm and 600 mm away from the left rear red side marker lamp</p> <p>fails to turn on during bulb-check cycle when power is supplied to auxiliary circuit (centre pin, blue wire)</p> <p>indicates the presence of an active malfunction by staying on after the bulb-check cycle</p> <p>any visual evidence that the system has been tampered with or defeated</p>
<p>b) wiring</p> <p><i>Additional Inspection Procedure(s):</i> Visually inspect accessible portions of the wiring. Inspect all repairs and damaged areas.</p>	<p>b) <i>insecure</i> mounting, <i>missing</i>, or connector corroded</p> <p>conductor is exposed due to damage, improper repair or other condition of wire</p> <p>connection or repair does not meet <i>OEM standard</i></p>
<p>c) electronic control unit (ECU)</p>	<p>c) <i>missing</i>, <i>insecure</i> mounting, connectors corroded</p>
<p>d) relay/ABS modulating valve</p>	<p>d) <i>missing</i>, leaking, <i>insecure</i> mounting to ECU, abnormal corrosion</p>
<p>e) wheel speed sensor</p> <p><i>Note:</i> Different configurations of sensors and modulators are permitted by <u>CMVSS</u>. Be sure to confirm the <i>OEM</i> configuration of the ABS before rejecting a vehicle due to missing wheel speed sensors.</p>	<p>e) <i>missing</i>, <i>insecure</i> mounting, <i>inoperative</i>, connectors corroded</p>
<p>f) PLC Signal to towing vehicle</p> <p><i>Note:</i> Power Line Carrier (PLC) communication is required for all trailers built on or after March 1, 2001.</p>	<p>f) PLC signal is <u>not</u> transmitted by trailer ABS</p> <p><i>Note:</i> When using Test Method 1 for the indicator lamp (trailer-mounted) above, PLC communication from the trailer is verified when the dash-mounted trailer ABS lamp in the towing vehicle turns on during bulb-check, and then turns off or stays on, to show the presence of a malfunction in conjunction with the trailer-mounted indicator lamp.</p> <p>(A malfunction may be described as a Fault, Diagnostic Fault Code, or Diagnostic Trouble Code.)</p>

Note: All inspection procedures are visual unless additional inspection procedures are indicated. Conditions shown ***in this manner*** are defined conditions. The definitions can be found in the introduction section.

ITEM AND METHOD OF INSPECTION:	REJECT IF:
	<p><u>Hazardous Condition(s)</u></p> <p>i. any malfunction of the ABS system that prevents normal brake operation</p>
<p><u>21. Stability Control System on Truck or Bus</u></p>	<p>NOT APPLICABLE TO TRAILERS</p>
<p><u>22. Stability Control System (Electronic Stability Control [ESC] or Roll Stability System [RSS]) on Trailer</u></p> <p><i>Additional Inspection Procedure(s):</i> Check the ECU for indication of any fault or malfunction in conjunction with inspection of the ABS as described in item 20 above.</p>	
<p>a) operation</p>	<p>a) **there is evidence that the system has been tampered with or defeated</p> <p>**the system has an active fault (light or indicator)</p> <p><i>Note:</i> Each of the conditions above marked with a double asterisk (**) are to be recorded on the inspection report, however a vehicle is not rejected for this condition alone.</p>
<p><u>23. Brake Performance</u></p> <p><i>Optional Additional Inspection Procedure(s):</i> These test methods can be used when one of the following types of performance-based brake tester (PBBT) is available. Test equipment must be calibrated and used according to <i>manufacturer</i> instructions.</p> <p>Testing a brake with non-burnished friction material may produce inconsistent test results.</p>	<p><i>Note:</i> Rated wheel weight = one-half of GAWR.</p>
<p>a) service brake force – using a roller-type performance-based brake tester (PBBT)</p> <p><i>Optional Additional Inspection Procedure(s):</i> Determine the maximum service brake force at each wheel by slowly applying the service brake pedal and increasing the pedal force until the tester terminates the test, or brake force reaches its maximum value.</p>	<p>a) service brake fails to lock the wheel <u>and</u> the maximum service brake force is less than 40% of the rated wheel weight</p> <p>service brake force on one side of the axle is less than 70% of the service brake force on the other side, at the point in time just prior to first wheel lockup, or test termination, whichever occurs first</p>

Note: All inspection procedures are visual unless additional inspection procedures are indicated. Conditions shown ***in this manner*** are defined conditions. The definitions can be found in the introduction section.

ITEM AND METHOD OF INSPECTION:	REJECT IF:
<p>b) parking brake output force – using a roller type brake tester</p> <p><i>Optional Additional Inspection Procedure(s):</i> <u>For wheels equipped with spring-brake type chambers used for parking</u>, Determine the maximum parking force at each wheel by fully applying the parking brake control until the tester terminates the test, or parking brake force reaches its maximum value.</p>	<p>b) parking brake fails to lock the wheel and the maximum parking brake force is less than 20% of rated wheel weight</p> <p>parking brake force on one side of the axle is less than 50% of the force on the other side, at the point in time just prior to first wheel lockup, or test termination, whichever occurs first</p>
<p>c) rolling resistance force – using a roller-type performance-based brake tester (PBBT)</p> <p><i>Optional Additional Inspection Procedure(s):</i> Determine average rolling resistance force of each wheel, with the brakes fully released, for one full revolution of the wheel. Discount the initial spike at start-up of the rolls.</p>	<p>c) average rolling resistance force of a wheel is greater than 6% of the weight of the wheel imparted on the test device</p>
<p>d) required brake force or stopping distance – using a decelerometer</p> <p><i>Optional Additional Inspection Procedure(s):</i> Test vehicle stopping ability in a suitable area following the instructions provided by the manufacturer/supplier of the test device.</p>	<p>d) deceleration is below the requirement of the relevant jurisdiction</p> <p>balance of brake force between left and right side fails to comply with the requirement of the relevant jurisdiction</p> <p><i>Note:</i> Brake force balance (left and right) cannot be measured with all types of decelerometers.</p>

Note: All inspection procedures are visual unless additional inspection procedures are indicated. Conditions shown *in this manner* are defined conditions. The definitions can be found in the introduction section.

Section 4 – Steering

ITEM AND METHOD OF INSPECTION:	REJECT IF:
<p>1. Steering Control and Linkage</p> <p><i>Additional Inspection Procedure(s):</i> Check the steering components listed below using tools and methods according to <u>manufacturer</u> service instructions.</p>	
a) steering box or rack and pinion unit	a) NOT APPLICABLE TO TRAILERS
b) bellow, clamp and boot	b) NOT APPLICABLE TO TRAILERS
c) tie rod	c) bent, broken, cracked or welded, or repaired in a way that does <u>not</u> meet OEM standard
d) tie rod end, drag link and ball and socket joint	d) bent, insecure , loose or worn threads stripped or repaired a ball and socket joint is worn beyond <u>manufacturer</u> specifications damaged , welded or repaired in a way that does <u>not</u> meet OEM standard part is used that does <u>not</u> meet OEM standard
e) pitman arm	e) NOT APPLICABLE TO TRAILERS
f) ball-joint in upper or lower control arm	f) NOT APPLICABLE TO TRAILERS
g) cotter pin or similar retaining device	g) missing , or deficient part is used that does <u>not</u> meet OEM standard
h) steering dampener	h) inoperative or missing level 2 leak of dampener fluid
i) steering column	i) NOT APPLICABLE TO TRAILERS
j) telescopic/tilt steering <i>Additional Inspection Procedure(s):</i> Check the operation of locking device(s). With unit locked, grasp the steering column and attempt to move it horizontally and vertically on its mounts.	j) NOT APPLICABLE TO TRAILERS
k) steering shaft universal joint and yoke	k) NOT APPLICABLE TO TRAILERS

Note: All inspection procedures are visual unless additional inspection procedures are indicated. Conditions shown **in this manner** are defined conditions. The definitions can be found in the introduction section.

ITEM AND METHOD OF INSPECTION:	REJECT IF:
l) steering column slip joint	l) NOT APPLICABLE TO TRAILERS
m) adjusting sleeve	m) bent, <i>loose</i> or welded or repaired in a way that does <u>not</u> meet <i>OEM standard</i> tightening bolt is in a position that interferes with normal steering
n) remote (right hand) steering control	NOT APPLICABLE TO TRAILERS
	<p><u>Hazardous Condition(s)</u></p> <p>i. any crack, modification or other condition that interferes with free movement of any steering component, or repair that does <u>not</u> meet <i>OEM standard</i></p> <p><u>Steering Linkage</u></p> <p>ii. any ball and socket joint has looseness in line with the shank or neck of the ball greater than <i>manufacturer</i> specification, or when specification is not available, greater than 3.0 mm</p> <p>iii. the socket of a ball and socket joint is injected with any repair material, or a ball and socket joint has been repaired in way, (e.g.: welded) that does <u>not</u> meet <i>OEM standard</i></p> <p>iv. any nut is <i>loose</i> or <i>missing</i></p> <p>v. <i>loose</i> clamp, clamp bolt or nut on tie rod, drag link, pitman arm, or steering arm</p> <p>vi. any looseness in any threaded joint</p>
<u>2. Power Steering System (Hydraulic and Electric)</u>	NOT APPLICABLE TO TRAILERS
<u>3. Steering Operation (Active Steer Axle)</u>	NOT APPLICABLE TO TRAILERS
<u>4. Kingpin</u>	
<p><i>Additional Inspection Procedure(s):</i> Raise the axle to unload the kingpin. Turn the wheels through a full right and left turn.</p>	
<p>a) lateral movement</p> <p><i>Additional Inspection Procedure(s):</i> Rock the wheel in and out, by hand or using a bar, to check for kingpin movement. Measure lateral movement at the outer edge of the tire.</p> <p>Use a dial gauge if necessary.</p>	<p>a) <u>not within manufacturer specification or when manufacturer specification is not available:</u></p> <ul style="list-style-type: none"> • for wheels <u>under</u> 20 in.: lateral movement is more than 3 mm • for wheels 20 in. <u>or larger</u>: lateral movement is more than 5 mm

Note: All inspection procedures are visual unless additional inspection procedures are indicated.

Conditions shown *in this manner* are defined conditions. The definitions can be found in the introduction section.

ITEM AND METHOD OF INSPECTION:	REJECT IF:
b) vertical movement <i>Additional Inspection Procedure(s):</i> Place a bar under the tire and check for vertical movement between spindle support and axle. Use a dial gauge if necessary.	b) <u>not</u> within <i>manufacturer</i> specification or when <i>manufacturer</i> specification is <u>not</u> available, greater than 2.5 mm
c) condition	c) binding or jamming is detected while turning wheel
	<u>Hazardous Condition(s)</u> i. binding or jamming caused by the kingpin or thrust bearings
<u>5. Self-Steer and Controlled-Steer Axle</u> <i>Note:</i> These are passive steer axles. A passive steer axle responds only to lateral force to turn wheels. The suspension components on a self-steer or controlled steer axle must be inspected according to Section 2, items 1-4. The steering components must be inspected according to items 1 & 4 above. <i>Additional inspection procedure(s):</i> Additional items may require inspection than those listed below. Refer to <i>manufacturer</i> service instructions related to the particular axle - for items in addition to those listed below - that are required to be inspected as part of a periodic safety inspection.	
a) operation <i>Additional Inspection Procedure(s):</i> Raise the vehicle and turn the wheels through a full right and left turn.	a) binding or jamming is detected while turning wheels
b) clearance	b) there is less than 25 mm between the tire and frame, fender or other vehicle part
c) steering stop	c) <i>missing</i> or <u>not</u> adjusted properly
d) air pressure regulator	d) <i>inoperative</i> or <i>missing</i>
e) pressure gauge	e) inaccurate, <i>inoperative</i> or <i>missing</i> <u>not</u> equipped with legible instruction indicating the minimum centering force pressure requirement
f) operating instruction label	f) <u>not</u> equipped with legible instruction indicating safe operation (such as: stating the speed at which the axle locks)

Note: All inspection procedures are visual unless additional inspection procedures are indicated. Conditions shown *in this manner* are defined conditions. The definitions can be found in the introduction section.

ITEM AND METHOD OF INSPECTION:	REJECT IF:
	<p data-bbox="740 226 1011 258"><u>Hazardous Condition(s)</u></p> <ul style="list-style-type: none"> <li data-bbox="740 289 1390 384">i. cracked, <i>loose</i> or <i>insecure</i> mounting, mounting bolt <i>missing</i> or <i>loose</i>, or has been repaired in way that does <u>not</u> meet <i>OEM standard</i> <li data-bbox="740 394 1328 426">ii. <i>inoperative</i> or <i>missing</i> steering lock on a C-dolly <li data-bbox="740 436 1284 468">iii. steering locks in any position except centred <p data-bbox="740 506 1430 590"><i>Note:</i> Also see Hazardous Conditions for items 1 to 4 in this section above</p>

Note: All inspection procedures are visual unless additional inspection procedures are indicated. Conditions shown *in this manner* are defined conditions. The definitions can be found in the introduction section.

Section 5 - Instruments & Auxiliary Equipment

ITEM AND METHOD OF INSPECTION:	REJECT IF:
<u>1. Fire Extinguisher</u>	
a) presence and type <i>Note:</i> Fire extinguisher requirements vary by jurisdiction. Inspection must be conducted according to the <i>applicable requirements</i> .	a) <i>missing</i> or incorrect type <i>not</i> in a quick-release holder within reach of driver <i>not</i> F.M., U.L. or U.L.C. approved and labelled <i>missing</i> on a vehicle required to meet <i>CSA</i> B620, D409, D435 or D436 standards
b) condition <i>Additional Inspection Procedure(s):</i> Check mounting security. Remove unit from holder and shake contents.	b) <i>insecure</i> or <i>loose</i> seal is broken or gauge shows less than minimum charge <i>no</i> movement of chemical is detected when unit is shaken nozzle or hose is clogged, defective or <i>missing</i> safety pin is <i>missing</i>
<u>2. Hazard Warning Kit</u>	NOT APPLICABLE TO TRAILERS
<u>3. Horn</u>	NOT APPLICABLE TO TRAILERS
<u>4. Instruments and Gauges on a Bus</u>	NOT APPLICABLE TO TRAILERS
<u>5. Speedometer</u>	NOT APPLICABLE TO TRAILERS
<u>6. Odometer</u>	NOT APPLICABLE TO TRAILERS
<u>7. Windshield Wiper/Washer</u>	NOT APPLICABLE TO TRAILERS
<u>8. Heater & Windshield Defroster</u>	NOT APPLICABLE TO TRAILERS
<u>9. Fuel-burning Auxiliary Heater</u>	NOT APPLICABLE TO TRAILERS
<u>10. Chain/ "Headache" Rack</u>	NOT APPLICABLE TO TRAILERS
<u>11. Auxiliary Controls and Devices</u>	NOT APPLICABLE TO TRAILERS
<u>12. Auxiliary Drive Controls</u>	NOT APPLICABLE TO TRAILERS
<u>13. On-board Auxiliary Equipment on a Bus</u>	NOT APPLICABLE TO TRAILERS
<u>14. First Aid Kit on a Bus</u>	NOT APPLICABLE TO TRAILERS
<u>15. Accessibility Features and Equipment on a Bus</u>	NOT APPLICABLE TO TRAILERS

Note: All inspection procedures are visual unless additional inspection procedures are indicated. Conditions shown ***in this manner*** are defined conditions. The definitions can be found in the introduction section.

Section 6 – Lamps

ITEM AND METHOD OF INSPECTION:	REJECT IF:
<p>1. Required Lamps</p> <p>a) operation of all required lamps</p> <p><i>Note:</i> See (page 62 to 64) for details on CMVSS 108 requirements for lamps, lamp location and colour.</p> <p><i>Additional Inspection Procedure(s):</i> Test the operation of all required lamps, lamp switches and controls, and lamp indicators.</p>	<p>a) fails to illuminate fully and correctly in response to the switch or control</p> <p>fails to turn off in response to the switch or control</p> <p>broken, cracked, <i>insecure</i> mounting or <i>missing</i>,</p> <p>lens is clouded or reduces transmission of light</p> <p>is <u>not</u> clearly visible or is covered in any manner</p> <p>does <u>not</u> meet <i>CMVSS</i>, DOT or SAE standards</p> <p>25% or more of LEDs of any one lamp assembly are <i>inoperative</i></p>
b) headlamp	b) NOT APPLICABLE TO TRAILERS
c) tail lamp	<p>c) broken, cracked, <i>inoperative</i> or <i>missing</i></p> <p>vehicle modification or installation of lamp causes tail lamp to be higher or lower than permitted by <i>CMVSS</i> 108</p> <p>the tail lamps fail to meet any of the following requirements:</p> <ul style="list-style-type: none"> • minimum of two lamps facing the rear, located at rear of vehicle and as far apart as practical, red in colour • illuminate correctly when operated by headlamp control
d) stop (brake) lamp	<p>d) broken, cracked, <i>inoperative</i> or <i>missing</i></p> <p>the stop lamps fail to meet any of the following requirements:</p> <ul style="list-style-type: none"> • minimum of two lamps facing the rear, located at rear of vehicle and as far apart as practical, red in colour • illuminate correctly when service brakes are applied
e) centre high mount stop lamp	e) NOT APPLICABLE TO TRAILERS

Note: All inspection procedures are visual unless additional inspection procedures are indicated. Conditions shown *in this manner* are defined conditions. The definitions can be found in the introduction section.

ITEM AND METHOD OF INSPECTION:	REJECT IF:
<p>f) turn signal lamp</p> <p><i>Note:</i> Not required on front of trailers.</p>	<p>f) broken, cracked, <i>inoperative</i> or <i>missing</i></p> <p>control is broken, <i>inoperative</i> or <i>missing</i></p> <p>control <u>fails to hold</u> selected position</p> <p>on a vehicle less than 2.05 m wide, control <u>fails to cancel</u> automatically when steering returns to centre</p> <p>turn signal indicator lamp on instrument panel is <i>inoperative</i></p> <p>the turn signal lamps fail to meet any of the following requirements:</p> <ul style="list-style-type: none"> • minimum of two facing the front, as far apart as practical, amber in colour • minimum of two facing the rear, as far apart as practical, amber or red in colour • illuminate correctly when operated by turn signal control
<p>g) hazard warning lamp</p> <p><i>Note:</i> Can operate same lamps as turn signals.</p>	<p>g) broken, cracked, <i>inoperative</i> or <i>missing</i></p> <p>control is broken, <i>inoperative</i> or <i>missing</i></p> <p>hazard warning indicator lamp on instrument panel is <i>inoperative</i></p> <p>the hazard warning lamps fail to meet any of the following requirements:</p> <ul style="list-style-type: none"> • minimum of two facing the front, as far apart as practical, amber in colour • minimum of two facing the rear, as far apart as practical, amber or red in colour • illuminate correctly and flash simultaneously when operated by hazard warning control
<p>h) side marker lamp</p> <p><i>Note:</i> A single lamp may serve as both a side marker and a clearance lamp, provided it is clearly visible from both the side and the rear.</p> <p>Vehicles 9.1 m or more in length require amber intermediate lamps.</p> <p>Intermediate side marker lamps are <u>not</u> required on vehicles less than 9.1 m in length.</p>	<p>h) broken, cracked, <i>inoperative</i> or <i>missing</i></p> <p>amber intermediate side marker lamps are <i>inoperative</i> or <i>missing</i> on a vehicle over 9.1 m in length</p> <p>the side marker lamps fail to meet any of the following requirements:</p> <ul style="list-style-type: none"> • minimum of four in total, two at the rear and two at the front, facing the side, • located as close to corners as practical • front are amber in colour • rear are red in colour

Note: All inspection procedures are visual unless additional inspection procedures are indicated. Conditions shown *in this manner* are defined conditions. The definitions can be found in the introduction section.

ITEM AND METHOD OF INSPECTION:	REJECT IF:
i) clearance lamp <i>Note:</i> Clearance lamps are required at the front and rear on all vehicles 2.05 m or more in width.	i) broken, cracked, <i>inoperative</i> or <i>missing</i> the clearance lamps fail to meet any of the following requirements: <ul style="list-style-type: none"> • minimum of four in total, located as far apart as practical at the widest point of the vehicle • two facing the front, as high as practical, amber in colour • two facing the rear, red in colour
j) identification lamp <i>Note:</i> Identification lamps are required at the front and rear on all vehicles 2.05 m or more in width, except as noted below. Front identification lamps are <u>not</u> required on trailers.	j) broken, cracked, <i>inoperative</i> or <i>missing</i> the identification lamps fail to meet any of the following requirements: <ul style="list-style-type: none"> • minimum of six in total • three facing the front, amber in colour • three facing the rear, red in colour
k) back up lamp	k) NOT APPLICABLE TO TRAILERS
l) licence plate lamp <i>Note:</i> A licence lamp may not be required in cases where no licence plate is required to be displayed.	l) broken, cracked, <i>inoperative</i> or <i>missing</i> <u>not</u> white, fails to illuminate licence plate
m) daytime running lamp	m) NOT APPLICABLE TO TRAILERS
n) fog lamp	n) NOT APPLICABLE TO TRAILERS
o) high beam driving lamp	o) NOT APPLICABLE TO TRAILERS
p) low beam driving lamp	p) NOT APPLICABLE TO TRAILERS
q) special equipment lamp <i>Note:</i> Some jurisdictions require or prohibit certain lamps in certain operations. Inspector must be familiar with the <u><i>applicable requirements</i></u> .	q) a lamp required for vocational or specialized operation is <i>inoperative</i> or <i>missing</i> a lamp that is prohibited by the <u><i>applicable requirements</i></u> installed a lamp that is required to be covered when not in use, has no cover

Note: All inspection procedures are visual unless additional inspection procedures are indicated. Conditions shown *in this manner* are defined conditions. The definitions can be found in the introduction section.

ITEM AND METHOD OF INSPECTION:	REJECT IF:
	<p><u>Hazardous Condition(s)</u></p> <ul style="list-style-type: none"> i. <u>not at least one head lamp is operative on a power unit</u> ii. <u>not at least one tail lamp is operative on the rear visible from 150 m</u> iii. <u>not at least one stop lamp is operative on the vehicle visible from 150 m</u> iv. <u>not at least one turn signal lamp is operative on each side at the rear, visible from 150 m</u> v. <u>not at least one turn signal lamp is operative on each side at the front, visible from 150 m</u> vi. <u>any required lamp is <i>inoperative</i> or obstructed during times when the lamp is required</u>
<p><u>2. Reflex Reflector</u></p> <p><i>Note:</i> A lamp's lens may also function as a reflex reflector.</p>	
<p>a) required reflectors</p> <p><i>Note:</i> See (page 62 to 64) for details on <u>CMVSS 108</u> requirements for reflex reflector location and colour.</p>	<p>a) any required reflex reflector, or part of a reflex reflector, is broken, <i>missing</i>, obscured or <u>not</u> clearly visible</p> <p><u>not</u> labelled to show compliance with <u>CMVSS</u>, DOT or SAE standards</p>
<p>b) rear reflector</p>	<p>b) <u>rear reflectors fail to meet any of the following requirements:</u></p> <p>minimum of two, located as far apart as practical, red in colour, between 380 and 1530 mm from centre of reflector to the ground</p>
<p>c) front and rear side, and intermediate reflex reflector</p> <p><i>Note:</i> Amber intermediate reflectors are required on all vehicles over 9.1 m in length.</p>	<p>c) amber intermediate reflex reflector is <i>missing</i> on a vehicle over 9.1 m in length</p> <p><u>front and rear reflex reflectors fail to meet any of the following requirements:</u></p> <ul style="list-style-type: none"> • minimum of four in total, located as far apart as practical, between 380 and 1530 mm from centre of reflector to the ground • two at the front, amber in colour • two at the rear, red in colour

Note: All inspection procedures are visual unless additional inspection procedures are indicated. Conditions shown ***in this manner*** are defined conditions. The definitions can be found in the introduction section.

ITEM AND METHOD OF INSPECTION:	REJECT IF:
<p><u>3. Retro-Reflective Marking</u></p> <p><i>Note:</i> Required on all trailers manufactured after January 10, 1997.</p> <p>In some jurisdictions applies retroactively to all trailers with a width of 2.05 m or more, and GVWR of 4,536 kg or more, regardless of manufacture date. Inspector must be familiar with the <i>applicable requirements</i>.</p> <p>See pages 62 to 64 for details on <u>CMVSS</u> 108 requirements for retro-reflective markings.</p>	
a) presence	a) any required section is <i>missing</i>
b) type/markings	b) consist of <u>anything other than</u> alternating red and white retro-reflective sheeting that is marked DOT- C2 (50 mm wide), DOT-C3 (75 mm wide) or DOT-C4 (100 mm wide)
c) condition	<p>c) peeling off or reflective properties are compromised on an area exceeding 77 cm² (12 in.2) of the entire surface of the required reflective material</p> <p><i>Note:</i> On 50 mm wide material, this means a total length of 15 cm having some loss of reflective property.</p>
d) location and type	d) retro-reflective markings <u>fail to meet</u> the requirements of <u>CMVSS</u> 108 as shown on page 143 to 148.
	<p><u>Hazardous Condition(s)</u></p> <p>i. more than 50% of retro-reflective material of any required section is compromised or <i>missing</i></p>
<u>4. Instrument Panel Lamp</u>	NOT APPLICABLE TO TRAILERS
<u>5. Headlamp Aim</u>	NOT APPLICABLE TO TRAILERS
<u>6. Interior Lamps on a Bus</u>	NOT APPLICABLE TO TRAILERS
<u>7. School Bus Additional Lamps</u>	NOT APPLICABLE TO TRAILERS

Note: All inspection procedures are visual unless additional inspection procedures are indicated. Conditions shown ***in this manner*** are defined conditions. The definitions can be found in the introduction section.

IMPORTANT NOTE: Every lamp, reflex reflector, and conspicuity treatment must be permanently attached in the location specified below and must comply with all applicable requirements prescribed for it by FMVSS/CMVSS 108. The face of any device on the front/rear and sides should be, respectively perpendicular and parallel to the vehicle's centerline, unless it is photometrically certified at installation angle. No part of the vehicle shall prevent any device from meeting its prescribed requirements unless an auxiliary device meeting all prescribed requirements is installed.

IN CANADA: Manufacturers and importers of vehicles must have the proper certification test records demonstrating compliance of lighting components with all prescribed requirements.

BASIC EQUIPMENT REQUIRED ON ALL TRAILERS

DESCRIPTION				MANDATORY REQUIREMENTS			
Area	Equipment	SAE Lens Coding	Functional Purpose	Quantity	Color	Location	Height mm(in.) from the ground
1	Tail Lamps	(T)	Indicate vehicle's presence and width	Minimum 2	Red	On the rear - symmetrical as far apart as practicable	380-1830 (15-72)
	Stop Lamps	(S)	Indicate braking	Minimum 2	Red	On the rear - symmetrical as far apart as practicable	380-1830 (15-72)
	Rear Turn Signal Lamps	(I)	Indicate direction of turn	Minimum 2	Red or Amber	On the rear - symmetrical as far apart as practicable	380-2110 (15-83)
	Rear Reflex Reflectors	(A)	Indicate vehicle's presence and width	Minimum 2	Red	On the rear - symmetrical as far apart as practicable facing rearward	380-1530 (15-60)
2	License Plate Lamp(s)	(L)	Illuminates license plate	Minimum 1	White	On the rear - above or at the sides of license plate	No requirement
3	Rear Side Marker Lamps <small>*photometrically certified at installation angle</small>	(P2, PC* or P3, PC2*)	Front and rear side marker lamps / side reflex reflectors indicate vehicle's presence and length	Minimum 2	Red	Each side at rear as far back as practicable	380-1530 (15-60) no max. for veh. under 2032mm (80") wide
	Rear Side Reflex Reflectors	(A)		Minimum 2	Red	Each side at rear as far back as practicable facing sideward	380-1530 (15-60)
4	Front Side Marker Lamps <small>*photometrically certified at installation angle</small>	(P2, PC* or P3, PC2*)	Front and rear side marker lamps / side reflex reflectors indicate vehicle's presence and length	Minimum 2	Amber	Each side at front as far forward as practicable	380 (15) minimum
	Front Side Reflex Reflectors	(A)		Minimum 2	Amber	Each side at front as far forward as practicable facing sideward	380-1530 (15-60)

ADDITIONAL EQUIPMENT FOR TRAILERS EXCEEDING THE FOLLOWING PARAMETERS
Length 9.1m (30 ft.) or longer

DESCRIPTION				MANDATORY REQUIREMENTS			
Area	Equipment	SAE Lens Coding	Functional Purpose	Quantity	Color	Location	Height mm(in.) from the ground
5	Intermediate Side Marker Lamps <small>*photometrically certified at installation angle</small>	(P2, P3, PC* or PC2*)	Indicate presence of a long vehicle	Minimum 2	Amber	Each side near center facing sideward	380 (15) minimum
	Intermediate Side Reflex Reflectors	(A)	Indicate presence of a long vehicle	Minimum 2	Amber	Each side near center facing sideward	380-1530 (15-60)

Width 2032mm (80 in.) or wider

DESCRIPTION				MANDATORY REQUIREMENTS			
Area	Equipment	SAE Lens Coding	Functional Purpose	Quantity	Color	Location	Height
6	Rear Clearance Lamps <small>*photometrically certified at installation angle</small>	(P2, PC* or P3, PC2*)	Show vehicle's width MAY NOT be combined with tail lamps	Minimum 2	Red	At widest point - symmetrical on the rear or near the rear facing rearward	As high as practicable may be lower only if ID lamps are at the top
7	Rear Identification (ID) Lamps	(P2 or P3)	Indicate presence of a wide vehicle	Exactly 3	Red	On the rear - center horizontally spaced 150mm (6 in.) to 300mm (12 in.) apart facing rearward	At the top - may be lower if door header narrower than 25mm
8	Front Clearance Lamps <small>*photometrically certified at installation angle</small>	(P2, PC* or P3, PC2*)	Show vehicle's width	Minimum 2	Amber	At widest point - symmetrical on the front or near the front facing forward	As high as practicable

Width 2032mm (80 in.) or wider AND GVWR 4536 kg (10,000 lb.) or more

DESCRIPTION		MANDATORY REQUIREMENTS					
Area	Conspicuity Treatment	DOT Coding	Quantity	Color	Location	Height	Options
9	Rear Upper Body Markings	DOT-C DOT-C2 DOT-C3 DOT-C4	Exactly 2 pairs of 300mm long strips	White	On the rear upper corners facing rearward	At the top	Reflex reflectors may not be required if they are replaced in their required location with conspicuity treatment.
10	Bumper Bar Marking		Continuous	Red/White	On the rear bumper bar's horizontal element full width - facing rearward	No requirement	
11	Rear Lower Body Marking		Continuous	Red/White (see options)	On the rear full width of the vehicle facing rearward	As horizontal as practicable and as close as practicable to the range of 375 to 1525mm from the ground	
12	Side Marking		(see location)	Red/White (see options)	Each side - facing sideward continuous, or evenly spaced over minimum of 50% of length starts and ends as close to the front and rear of the vehicle as practicable	As horizontal as practicable and as close as practicable to the range of 375 to 1525mm from the ground	Optional In Canada: Rear lower body and side conspicuity treatment may also be solid white, solid yellow, or white and yellow.

NOTE: The edge of red conspicuity tape shall not be closer than 75 mm to the edge of any amber lamp and the edge of white conspicuity tape shall not be closer than 75 mm to the edge of any lamp

Note: All inspection procedures are visual unless additional inspection procedures are indicated. Conditions shown *in this manner* are defined conditions. The definitions can be found in the introduction section.

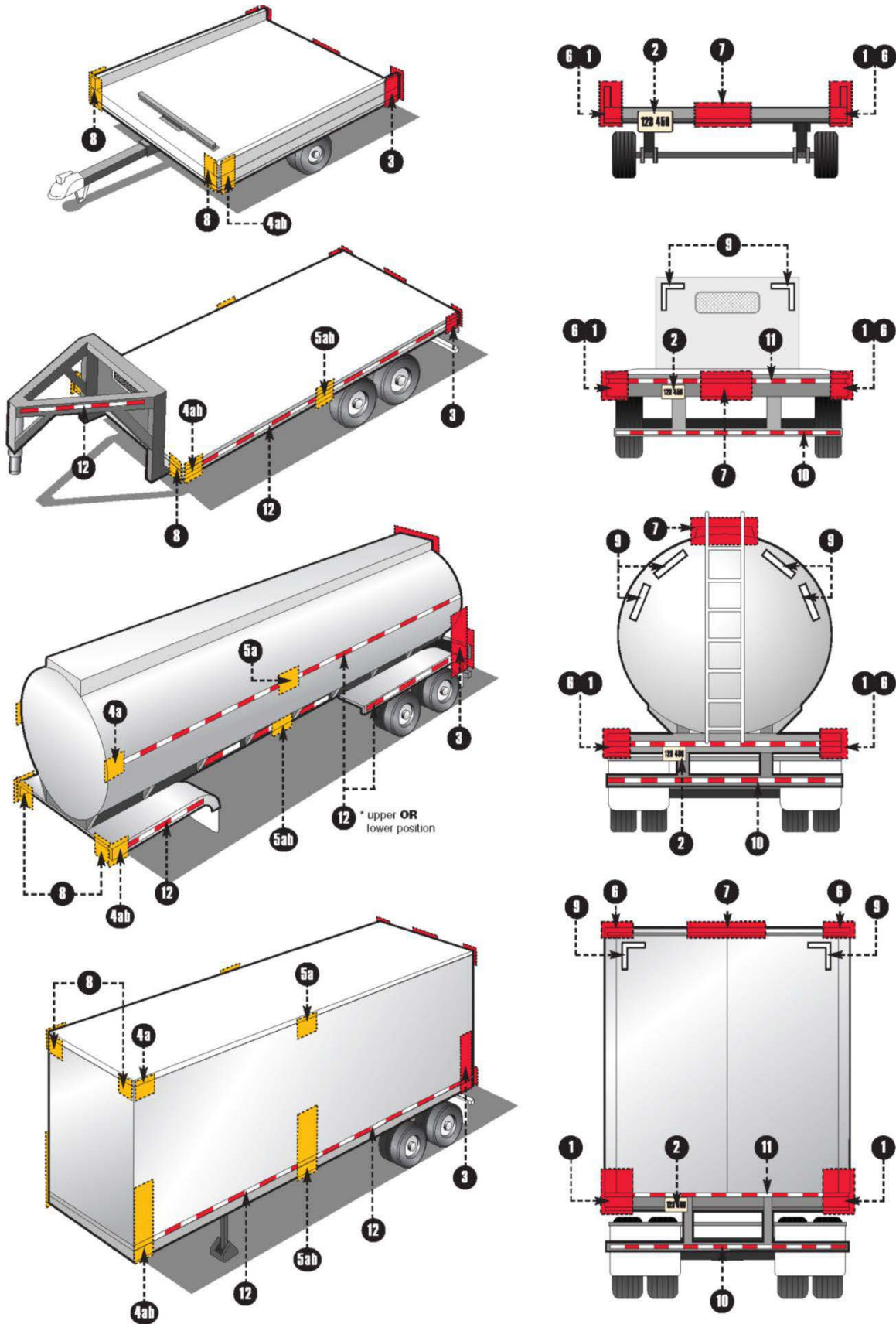

Note: All inspection procedures are visual unless additional inspection procedures are indicated. Conditions shown *in this manner* are defined conditions. The definitions can be found in the introduction section.

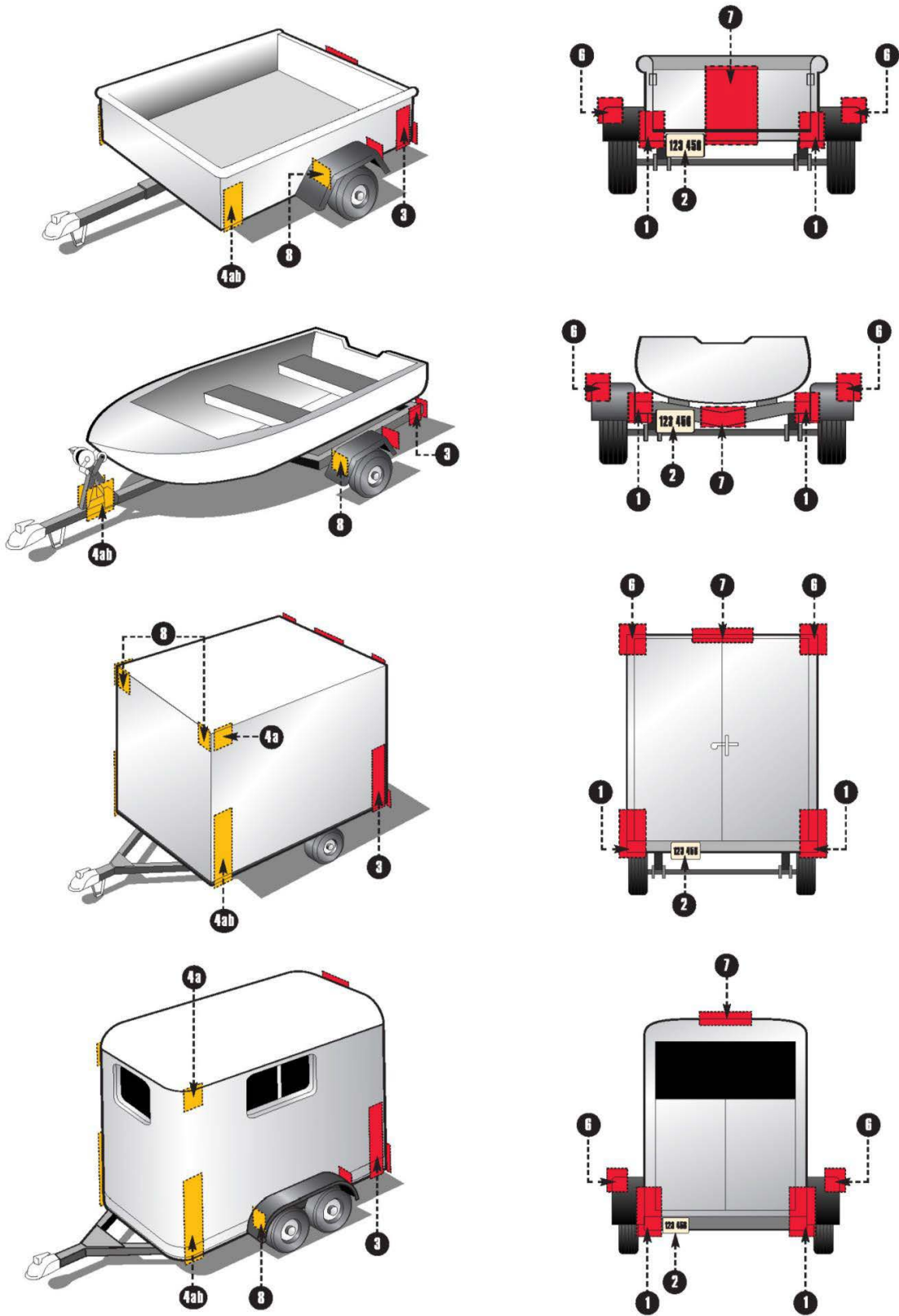

Note: All inspection procedures are visual unless additional inspection procedures are indicated. Conditions shown *in this manner* are defined conditions. The definitions can be found in the introduction section.

Section 7 – Electrical System

ITEM AND METHOD OF INSPECTION:	REJECT IF:
<p>1. Wiring</p> <p><i>Additional Inspection Procedure(s):</i> Inspect wiring, harnesses and connections that are accessible and visible. Pay particular attention to battery, starter and charging system circuits.</p>	
a) security	a) <i>loose</i> or improperly supported, and able to contact moving parts chafed section resulting from contact with vehicle parts <i>not</i> secured at least every 1800 mm
b) insulation	b) conductor is exposed, other than at a proper connector
c) condition	c) cut, shorted or deteriorated connection is <i>loose</i> , abnormally corroded, burnt
d) circuit loading <i>Note:</i> Circuit protection requirements are based on <i>manufacturer</i> design and specifications. Circuit testing is not required. Inspection is visual and based on knowledge of the normal design and specifications.	d) circuit load protection is <i>missing</i> or bypassed circuit is overloaded beyond normal circuit capacity circuit protection device (fuse, circuit breaker or fusible link) exceeds circuit capacity circuit is improperly grounded
	<p><u>Hazardous Conditions</u></p> <p>i. any electrical component or wiring shows signs of shorting, arcing, or a hot spot</p>
<p>2. Battery</p>	
a) posts and connections	a) corrosion or deterioration is present that prevents proper electrical contact, <i>loose</i> or burnt
b) mount	b) cracked or <i>missing</i> , perforated or weakened due to corrosion
c) cover and hold down	c) <i>insecure</i> , <i>missing</i> , does <i>not</i> meet <i>OEM standard</i> battery is not secured in place
d) condition	d) <i>level 2 leak</i> of battery fluid
	<p><u>Hazardous Conditions</u></p> <p>i. any electrical component or wiring shows signs of shorting, arcing, or a hot spot</p>

Note: All inspection procedures are visual unless additional inspection procedures are indicated. Conditions shown ***in this manner*** are defined conditions. The definitions can be found in the introduction section.

ITEM AND METHOD OF INSPECTION:	REJECT IF:
3. Trailer Cord (output to towed vehicle)	
a) insulation b) connection <i>Note:</i> A trailer cord must be repaired only by using <i>industry standard</i> methods.	a) cut, cracked, deteriorated or melted through to wire conductor b) cracked, ends split, improper repair or connection
c) constant ABS power on auxiliary circuit <i>Note:</i> Also refer to Section 3A, Item 18 f) PLC communication). Every vehicle equipped for towing another vehicle with air brakes, manufactured after April 1, 2000, must supply constant power to the trailer auxiliary circuit (center pin, blue wire) while the ignition is in the “on” position. <i>Additional Inspection Procedures(s):</i> Confirm that voltage is present at the auxiliary pin in the trailer cord when the ignition is ‘on’ by one of the following methods: Option 1 – Test with a voltmeter. Option 2 – Connect to a test device.	c) power is <u>not</u> continuously supplied to the auxiliary circuit when ignition is “on” a switch is installed that can interrupt power to the auxiliary circuit voltage is below required minimum when circuit is loaded to <i>industry standard</i> value
4. Alternator Output on a School Bus	NOT APPLICABLE TO TRAILERS

Note: All inspection procedures are visual unless additional inspection procedures are indicated. Conditions shown ***in this manner*** are defined conditions. The definitions can be found in the introduction section.

Section 8 – Body

ITEM AND METHOD OF INSPECTION:	REJECT IF:
1. Hood or Engine Enclosure	NOT APPLICABLE TO TRAILERS
2. Tilt Cab	NOT APPLICABLE TO TRAILERS
3. Air-Suspended Cab	NOT APPLICABLE TO TRAILERS
4. Cab and Passenger-Vehicle Body	NOT APPLICABLE TO TRAILERS
5. Cargo Body <i>Additional Inspection Procedure(s):</i> Where any sheet metal, structural item or fastener is suspected of being loose or perforated, determine the integrity of the suspect item or area by lightly tapping it with a hammer. <i>Note:</i> Minor surface rust and corrosion is normal.	
a) sheet metal	a) any section has exposed sharp edge, is torn or protrudes out in a manner that could be hazardous to driver, passenger, pedestrian or cyclist panel is <i>insecure, loose</i> or corroded through rivet is <i>loose, missing</i> welded or repaired in a way that does <u>not</u> meet <i>OEM standard</i>
b) floor & deck	b) has any condition that allows a person or cargo to fall through has a hole larger than 200 mm across the longest dimension welded or repaired in a way that does <u>not</u> meet <i>OEM standard</i>
c) frame & sub-frame	c) bulge caused by corrosion resulting in distortion of 10 mm or more (unless the condition or the repair is approved by the <i>OEM, manufacturer</i> or an engineer) stress crack at side rail or rub-rail rivet is <i>loose, missing</i> , dimpled by corrosion bent, broken, cracked or <i>insecure</i> welded or repaired in a way that does <u>not</u> meet <i>OEM standard</i>
d) cross-member	d) bent, broken, collapsed, cracked or <i>missing</i> perforated or weakened by corrosion

Note: All inspection procedures are visual unless additional inspection procedures are indicated. Conditions shown ***in this manner*** are defined conditions. The definitions can be found in the introduction section.

ITEM AND METHOD OF INSPECTION:	REJECT IF:
e) inner or outer side rail and body-long sills	e) bulge caused by corrosion resulting in distortion of 10 mm or more (unless the condition or the repair is approved by the <i>OEM, manufacturer</i> or an engineer) rivet is <i>loose, missing</i> bent, broken, cracked or <i>insecure</i> welded or repaired in a way that does <u>not</u> meet <i>OEM standard</i>
f) stake pocket/tiedown, cargo securing point or cargo securing device	f) broken, cracked or <i>insecure</i> elongated or distorted <i>Note:</i> When a cargo securing point or device is in any of the conditions described above, record the condition on the inspection report, do not reject the vehicle for this condition alone.
g) tailgate, hopper, or end-dump door	g) broken, cracked or <i>missing</i> hinge is broken, cracked or <i>missing</i> , or pin lock is <i>missing</i> <i>insecure</i> , or will <u>not</u> close and latch properly any gap exists that would allow leakage, loss or spillage of cargo welded or repaired in a way that does <u>not</u> meet <i>manufacturer standard</i>
h) body to frame attachment <i>Note:</i> Includes body to frame attachment device such as 'U- bolt', pivot hinge, cheek plate mount, flex-mount hardware, body clamp and 'J-Bar'.	h) bent, broken, cracked, <i>loose</i> or <i>missing</i> spring is broken spacer or insulator is abnormally worn, crushed, dislodged or missing
i) body rail and structural member	i) upper or lower cargo body rail is bent, buckled, has a crack longer than 25 mm, or has a fastener <i>loose</i> or <i>missing</i> floor cross member is bent, <i>loose</i> or sagging roof support is bent, <i>loose</i> or sagging

Note: All inspection procedures are visual unless additional inspection procedures are indicated. Conditions shown ***in this manner*** are defined conditions. The definitions can be found in the introduction section.

ITEM AND METHOD OF INSPECTION:	REJECT IF:
<p>j) body panel</p>	<p>j) any section has exposed sharp edge, is torn or protrudes out in a manner that could be hazardous to driver, passenger, pedestrian or cyclist</p> <p>panel or panel fastener is <i>insecure, loose, missing</i>, or corroded through</p> <p>rivet is <i>loose</i></p> <p>repaired in a way that does <u>not</u> meet <i>OEM standard</i></p> <p>any gap exists that would allow leakage, loss or spillage of cargo</p>
	<p><u>Hazardous Condition(s)</u></p> <p>i. any component is so <i>insecure</i> or <i>loose</i> that it is an imminent hazard or it could become detached from vehicle</p> <p>ii. any section has exposed sharp edge, is torn or protrudes out in a manner that is hazardous to driver, passenger, pedestrian or cyclist</p> <p>iii. any body part or attachment is broken, cracked perforated, or sagging, in a manner that permits the body to contact any moving part, or imminent collapse appears likely</p> <p>iv. any gap exists allowing leakage, loss or spillage of cargo</p> <p>v. a cargo body upper or lower rail is buckled, bowed, cracked through, sagging or has two or more adjacent <i>loose</i> or missing fasteners</p> <p>vi. two or more adjacent floor cross members are bent, <i>loose</i> or sagging</p> <p>vii. two or more adjacent roof supports are bent, <i>loose</i> or sagging</p>
<p><u>6. Frame, Rails & Mounts</u></p>	
<p>a) condition</p> <p><i>Note:</i> Some rust and corrosion on the outer surface of exposed metal parts is normal. When a high amount of rust or corrosion is present and visibly reduces the thickness of the material, structural deterioration is possible.</p>	<p>a) welded, modified or repaired in a way that does <u>not</u> meet <i>OEM standard</i></p> <p>bent, broken or cracked</p> <p>perforated or separated due to corrosion between mount and frame member</p> <p>rusted or corroded to a depth sufficient to become weakened</p> <p>bulge caused by corrosion resulting in distortion of 10 mm or more (unless the condition or the repair is approved by the <i>OEM, manufacturer</i> or an engineer)</p> <p>any condition of the frame assembly allows a frame component, or a part of the body or power train, to be more than 25 mm out of its normal position, or to contact a moving part</p>

Note: All inspection procedures are visual unless additional inspection procedures are indicated. Conditions shown *in this manner* are defined conditions. The definitions can be found in the introduction section.

ITEM AND METHOD OF INSPECTION:	REJECT IF:
b) frame fastener	b) ineffective, <i>loose</i> or <i>missing</i>
c) cross-member	c) bent, broken, cracked, <i>loose</i> or <i>missing</i> cut, notched, rusted or corroded to a depth sufficient to cause weakness repaired using material or method, that does <u>not</u> meet <u>OEM standard</u> or <u>industry standard</u> any condition of a cross member allows a frame component, or a part of the body or power train, to be more than 25 mm out of its normal position, or to contact a moving part
d) sub-frame assembly <i>Note:</i> This only applies to a structural frame assembly that is not part of the main frame assembly, and carries a load or provides strength to the vehicle structure, i.e.: engine cradle, or suspension sub-frame.	d) bent, broken, cracked, <i>loose</i> or <i>missing</i> cut, notched, rusted or corroded to a depth sufficient to cause weakness repaired using material or method that does <u>not</u> meet OEM standard or industry standard any condition of the sub-frame assembly allows a frame component, or a part of the body or power train, to be more than 25 mm out of its normal position, or to contact a moving part
	<p><u>Hazardous Condition(s)</u></p> <p>i. any frame side-rail or cross-member is cracked as follows:</p> <ul style="list-style-type: none"> • longer than 38 mm • longer than 25 mm in the bottom flange • from the web extending around the radius and into the bottom flange <p>ii. any condition of the frame allows a frame component, or a part of the body or power train, to be more than 38 mm out of its normal position, or to contact a moving part</p> <p>iii. imminent failure appears likely due to a frame member that is <i>damaged</i> or deteriorated, or has been repaired using material or method, that does <u>not</u> meet <u>OEM standard</u> or <u>industry standard</u></p>

Note: All inspection procedures are visual unless additional inspection procedures are indicated. Conditions shown *in this manner* are defined conditions. The definitions can be found in the introduction section.

ITEM AND METHOD OF INSPECTION:	REJECT IF:
<p>7. Unitized Body Elements</p> <p>a) load carrying panel, bulkhead, structural element and mounts</p> <p><i>Note:</i> Some rust and corrosion on the outer surface of exposed metal parts is normal. When a high amount of rust or corrosion is present and visibly reduces the thickness of the material, structural deterioration is possible.</p>	<p>a) bent, broken, cracked, <i>loose</i> or <i>missing</i></p> <p>cut or notched more than 25 mm, or rusted or corroded to a depth sufficient to cause weakness</p> <p>welded or repaired in a way that does <i>not</i> meet <i>OEM standard</i></p> <p>any rivet is <i>loose</i> or <i>missing</i></p> <p>any condition of the unitized body allows a part of the body or power train, to be more than 25 mm out of its normal position, or to contact a moving part</p>
	<p><u>Hazardous Condition(s)</u></p> <p>i. any component is so <i>insecure</i> or <i>loose</i> that it could become detached from the vehicle</p> <p>ii. structural body component has a crack, cut or notch longer than 38 mm</p> <p>iii. any condition of a unitized body component allows a part of the body or power train to be more than 38 mm out of its normal position, or to contact a moving part</p> <p>iv. imminent failure appears likely due to a body component that is <i>damaged</i> or deteriorated, or has been repaired using material or method, that does <i>not</i> meet <i>OEM standard</i> or <i>industry standard</i></p>
<p>8. Cab or Cargo Door</p>	
<p>a) condition and operation</p> <p><i>Additional Inspection Procedure(s):</i> Test the operation of each door.</p> <p><i>Note:</i> This includes a partition door between the occupant and cargo area.</p>	<p>a) binds or <i>fails to</i> lock securely</p> <p><i>insecure</i> mounting to hinge, <i>insecure</i> hinge or severely corroded in hinge area</p> <p>panel is corroded through</p> <p>welded or repaired in a way that does not meet OEM standard</p> <p>door fails to operate or latch on both primary and secondary latches</p> <p>gap exists that may allow exhaust gases to enter cab, passenger compartment, and/or sleeper</p> <p>seal is out of position, <i>damaged</i> or <i>missing</i>, and is able to allow exhaust gases to enter cab, passenger compartment, and/or sleeper</p> <p>any gap exists that would allow leakage, loss or spillage of cargo</p>

Note: All inspection procedures are visual unless additional inspection procedures are indicated. Conditions shown ***in this manner*** are defined conditions. The definitions can be found in the introduction section.

ITEM AND METHOD OF INSPECTION:	REJECT IF:
b) door openers and handles	b) broken, <i>inoperative</i> or <i>missing</i> catch or latch is broken, <i>loose</i> or <i>missing</i>
	<p><u>Hazardous Condition(s)</u></p> <ul style="list-style-type: none"> i. cab door fails to latch on both primary and secondary latches ii. cargo door fails to latch iii. gap exists and exhaust gases are entering cab, passenger compartment or sleeper iv. any gap exists allowing leakage, loss or spillage of cargo
<p><u>9. Cargo Tank or Vessel</u></p> <p><i>Note:</i> Code (e.g.: dangerous goods <u>CSA</u> B620, edible product, dry bulk) cargo tanks are frequently subject to additional inspection requirements. Inspections conducted in accordance with this standard address only a limited portion of the compliance requirements.</p> <p>This inspection does not include any procedure that requires operation of any valve, hatch or product handling item. Technician-inspector must take precautions to avoid exposure to any cargo or residual material.</p>	
a) condition	a) welded or repaired in a way that does <u>not</u> meet <u>OEM standard</u> <i>loose</i> on mounts <u>level 2 leak</u> of any liquid transported by the tank or vessel crack or broken weld in tank, frame or support movement, bulge or weakness caused by corrosion between tank and frame
b) valve	b) cap <i>loose</i> or <i>missing</i> <u>level 2 leak</u> of any liquid transported by the tank or vessel
c) hose	c) <i>loose</i> or improperly secured
d) hatch	d) <i>insecure</i> , <i>loose</i> or <i>missing</i> latch <i>inoperative</i> hinge, broken or <i>inoperative</i>

Note: All inspection procedures are visual unless additional inspection procedures are indicated. Conditions shown *in this manner* are defined conditions. The definitions can be found in the introduction section.

ITEM AND METHOD OF INSPECTION:	REJECT IF:
	<p><u>Hazardous Condition(s)</u></p> <ul style="list-style-type: none"> i. any component is so <i>insecure</i> or <i>loose</i> that it could become detached from vehicle ii. required internal valve is <i>missing</i> iii. internal valve remains open when it is required to be closed iv. access/fill/inspection opening cover is improperly secured or <i>missing</i> v. required venting device, emergency device, or discharge valve, is <i>missing</i>
<p><u>10. Body, Device or Equipment Attached or Mounted to the Vehicle</u></p>	
<p><i>Note:</i> This section applies primarily to external devices or equipment attached to a vehicle. Examples include a crane, cargo lifting and transporting machine, load covering equipment, cargo dispensing equipment, APU, refrigeration-heater (reefer) unit, generator, ready-mix unit, sander body, feed & grain body, snow plow, service/utility body, vacuum tank, flatbed, roll-on/roll-off, lugger, ISO container chassis, etc.</p> <p>The criteria in this section only apply to a mounted body, device or equipment to the extent that the condition could affect the safe operation of the vehicle on the highway. The functionality of the mounted equipment does not need to be tested or inspected.</p>	
<p>a) security and condition</p> <p><i>Additional Inspection Procedure(s):</i> Check security of attached body, device or equipment visually, manually and using suitable tools as necessary. No functional test is to be conducted.</p>	<p>a) equipment or device is in such an unsafe condition that is a risk to other motorists, the driver, a passenger, pedestrian or cyclist</p> <p>equipment or device is <i>insecure</i> or <i>loose</i>, or in danger of shifting in a way that could impede normal operation of the vehicle</p> <p>any section has an exposed sharp edge, is torn or protrudes out in a manner that could be hazardous to the driver, a passenger, pedestrian or cyclist</p> <p><i>level 3 leak</i> of any oil, hydraulic fluid or liquid product</p>

Note: All inspection procedures are visual unless additional inspection procedures are indicated. Conditions shown *in this manner* are defined conditions. The definitions can be found in the introduction section.

ITEM AND METHOD OF INSPECTION:	REJECT IF:
	<p><u>Hazardous Condition(s)</u></p> <ul style="list-style-type: none"> i. any article, component or device is so <i>insecure</i> or <i>loose</i> that it could become detached from vehicle ii. equipment or device is in such an unsafe condition that is a risk to other motorists, the driver, a passenger, pedestrian or cyclist iii. any section has an exposed sharp edge, is torn or protrudes out in a manner that could be hazardous to the driver, a passenger, pedestrian or cyclist
<p><u>11. Refrigeration/Heater Unit Fuel System (Reefer or Auxiliary Power Unit [APU])</u></p> <p><i>Note:</i> Inspect the condition and security according to item 10 above.</p> <p>Inspect the exhaust system and fuel system, according to the appropriate type of fuel used, as described in Section 1 – Power Train.</p>	
<u>12. Bumper</u>	NOT APPLICABLE TO TRAILERS
<u>13. Windshield</u>	NOT APPLICABLE TO TRAILERS
<u>14. Side Windows</u>	NOT APPLICABLE TO TRAILERS
<u>15. Rear Window</u>	NOT APPLICABLE TO TRAILERS
<u>16. Interior Sun Visor</u>	NOT APPLICABLE TO TRAILERS
<u>17. Exterior Windshield Sun Visor</u>	NOT APPLICABLE TO TRAILERS
<u>18. Rear-view Mirror</u>	NOT APPLICABLE TO TRAILERS
<u>19. Seat</u>	NOT APPLICABLE TO TRAILERS
<u>20. Seat Belt/Occupant Restraint</u>	NOT APPLICABLE TO TRAILERS

Note: All inspection procedures are visual unless additional inspection procedures are indicated. Conditions shown *in this manner* are defined conditions. The definitions can be found in the introduction section.

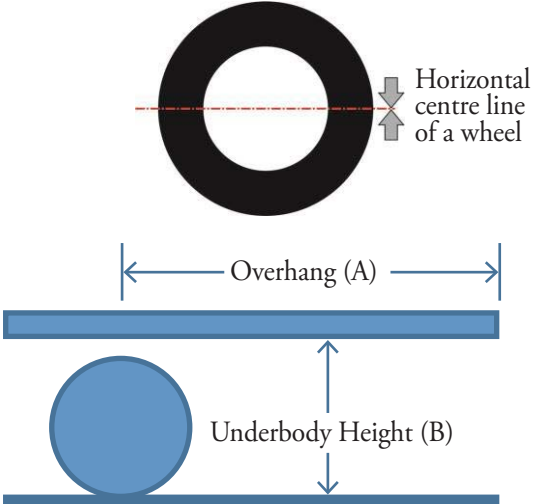
ITEM AND METHOD OF INSPECTION:	REJECT IF:
<p>21. Fender/Mud Flap</p> <p><i>Note:</i> A mud flap is required behind every wheel or axle group, where the full width of the tire is not enclosed by a body element, such as a fender, down at least as far as the wheel's horizontal centre line. Unless exempt as noted below, the mud flap must meet the following dimensions.</p> <p>Mud flap width - at least as wide as the tires.</p> <p>Bottom of mud flap - no more than 210 mm from the ground.</p> <p>Top of mud flap - must extend upward at least as high as the top of the tire(s), or up to a body element that extends below the top of the tire.</p> <p>Mud flap exemptions:</p> <p>A mud flap is not required where the body overhang is more than three times the underbody height.</p> <p><i>Overhang</i> = (A) the distance from the vertical centre line of the tire to the end of the body</p> <p><i>Underbody height</i> = (B) the distance from the bottom of the body overhang to the ground</p> <p>Mud flap location and dimensions may vary on a vocational vehicle, where the mud flap will interfere with vehicle operation, and on a vehicle with movable suspension, where there is inadequate room for a full size mud flap.</p>	
<p>a) condition and location</p>	<p>a) fender or mud flap is broken, has <i>insecure</i> mounting, is <i>loose</i> or <i>missing</i></p> <p>fender or mud flap has a tear or wear hole exists that is larger than 100 mm across the longest dimension, or the aggregated longest dimensions of multiple holes in a single mud flap equal more than 100 mm</p> <p>the distance from the bottom of the mud flap to the ground exceeds 210 mm</p> <p>the mud flap does not cover the full tread width of the tire(s)</p> <p>the top of the mud flap does not reach up to the top of the tires or a body element</p>

Note: All inspection procedures are visual unless additional inspection procedures are indicated. Conditions shown *in this manner* are defined conditions. The definitions can be found in the introduction section.

ITEM AND METHOD OF INSPECTION:	REJECT IF:
	<p><u>Hazardous Condition(s)</u></p> <p>i. required mud flap is missing</p>
<p><u>22. Landing Gear on Trailer</u></p>	
<p>a) operation</p> <p><i>Additional Inspection Procedure(s):</i> Test the operation of the landing gear in all speed settings.</p>	<p>a) binding, <i>inoperative</i> or seized</p>
<p>b) condition</p>	<p>b) landing gear or brace is bent, broken or cracked</p> <p><i>insecure</i> mounting</p> <p>pad broken, <i>insecure</i> or <i>loose</i>, or <i>missing</i></p>
<p>c) crank handle</p>	<p>c) <u>cannot</u> be stowed or secured so that it remains within the outer dimensions of the vehicle</p>
	<p><u>Hazardous Condition(s)</u></p> <p>i. any part of the landing gear is <i>insecure</i> or <i>loose</i> or so as to become detached from vehicle</p>
<p><u>23. Sliding Axle Assembly (Sliding Bogie) on Trailer</u></p>	
<p>a) frame and sub-frame rail</p>	<p>a) welded or repaired in a way that does <u>not</u> meet <i>OEM standard</i></p> <p>bent, broken or cracked</p> <p>any attaching weld is broken or cracked</p> <p>perforated or separated due to corrosion between mount and frame member</p> <p>rusted or corroded to a depth sufficient to become weakened</p>
<p>b) slider-guide/hold-down bracket & locking device</p>	<p>b) cracked or <i>missing</i></p> <p><i>inoperative</i> or <u>fails to</u> lock securely</p> <p>any lock pin is broken, cracked, disengaged or <i>missing</i></p> <p>locking device (pin) is worn causing 25% or greater reduction in diameter</p> <p>locking-pin hole measures more than 25 mm larger than its original size</p>
<p>c) stop</p>	<p>c) bent, cracked, <i>loose</i> or <i>missing</i></p>

Note: All inspection procedures are visual unless additional inspection procedures are indicated. Conditions shown *in this manner* are defined conditions. The definitions can be found in the introduction section.

ITEM AND METHOD OF INSPECTION:	REJECT IF:
	<p><u>Hazardous Condition(s)</u></p> <ul style="list-style-type: none"> i. more than one-fourth of the slider locking pins or locking pin holes that are in use have any one of the following conditions: <ul style="list-style-type: none"> • locking pin is missing or not engaged • locking-pin hole measures more than 25 mm larger than its original size • the material from the hole in use to an adjacent hole, or the material from the hole in use to the edge of the rail, is torn or split ii. more than one-fourth of the slider-guide/hold- down brackets are missing or disengaged iii. the sliding suspension attachment member (undercarriage body rail) on either side has a crack of any length in more than 50 percent of its attachment welds iv. a sliding suspension member's (undercarriage body rail) attachment welds are cracked completely through along a 1.2 m continuous length of the body rail v. a sliding suspension attachment member (undercarriage body rail) is cracked completely through along a 1.2 m continuous length
<u>24. Aerodynamic Device and Attachment</u>	
a) condition and security	<p>a) <i><u>insecure</u></i> or <i><u>loose</u></i></p> <p>any section has exposed sharp edge, is torn or protrudes out in a manner that could be hazardous to driver, passenger, pedestrian or cyclist</p>
	<p><u>Hazardous Condition(s)</u></p> <ul style="list-style-type: none"> i. aerodynamic device is so <i><u>insecure</u></i> or <i><u>loose</u></i> it is likely to become detached from the vehicle ii. any section has exposed sharp edge, is torn or protrudes out in a manner that could be hazardous to driver, passenger, pedestrian or cyclist

Note: All inspection procedures are visual unless additional inspection procedures are indicated. Conditions shown *in this manner* are defined conditions. The definitions can be found in the introduction section.

ITEM AND METHOD OF INSPECTION:	REJECT IF:
<p>25. Rear Impact Guard (RIG) on Trailer</p> <p><i>Note:</i> Every trailer with a GVWR of 4,536 kg or greater manufactured on or after September 23, 2007, except as noted below, must be fitted with a rear impact guard (RIG) that meets the requirements of <u>CMVSS</u> 223.</p> <p>Trailers not required by <u>CMVSS</u> to have RIG include:</p> <ul style="list-style-type: none"> • pole trailer • pulpwood trailer • wheels-back trailer • trailer designed to be used as temporary living quarters • low chassis trailer • trailer designed to interact with, or having, work performing equipment located in or moving through the area that would be occupied by a RIG 	
<p>a) dimensions</p> <p><i>Note:</i> All RIG dimensions are based on the trailer being in an unloaded condition, suspension at normal ride height and tires properly inflated.</p>	<p>a) RIG does not conform to dimensions shown in figure 1 below (based on <u>industry standard</u> - TMC RP 732)</p>
<p>b) condition</p> <p><i>Note:</i> Multiple bends are permitted.</p> <p>When there is visible damage to the RIG, also carefully inspect the trailer frame and floor for structural damage.</p>	<p>b) broken, <u>loose</u> or <u>missing</u></p> <p>has cracked welds in the horizontal or vertical member or in the supporting structure or any attachment to vehicle structure</p> <p>the horizontal member is bent inward, downward, upward or outward, beyond 75 mm as shown in figure 2 below</p> <p>the vertical supports and/or supporting structure are weakened, bent or distorted (See figure 3 below)</p>

Note: All inspection procedures are visual unless additional inspection procedures are indicated. Conditions shown in this manner are defined conditions. The definitions can be found in the introduction section.

ITEM AND METHOD OF INSPECTION:

REJECT IF:

Figure 1 – Rear Impact Guard Dimensions

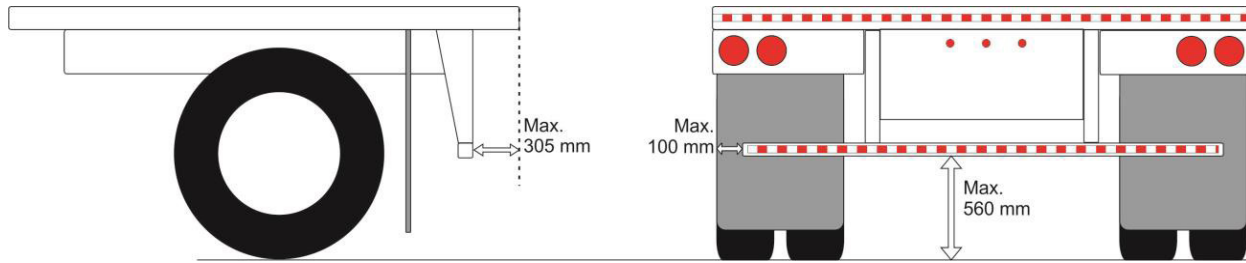

Figure 2 – Limits of Damage to Horizontal RIG Member

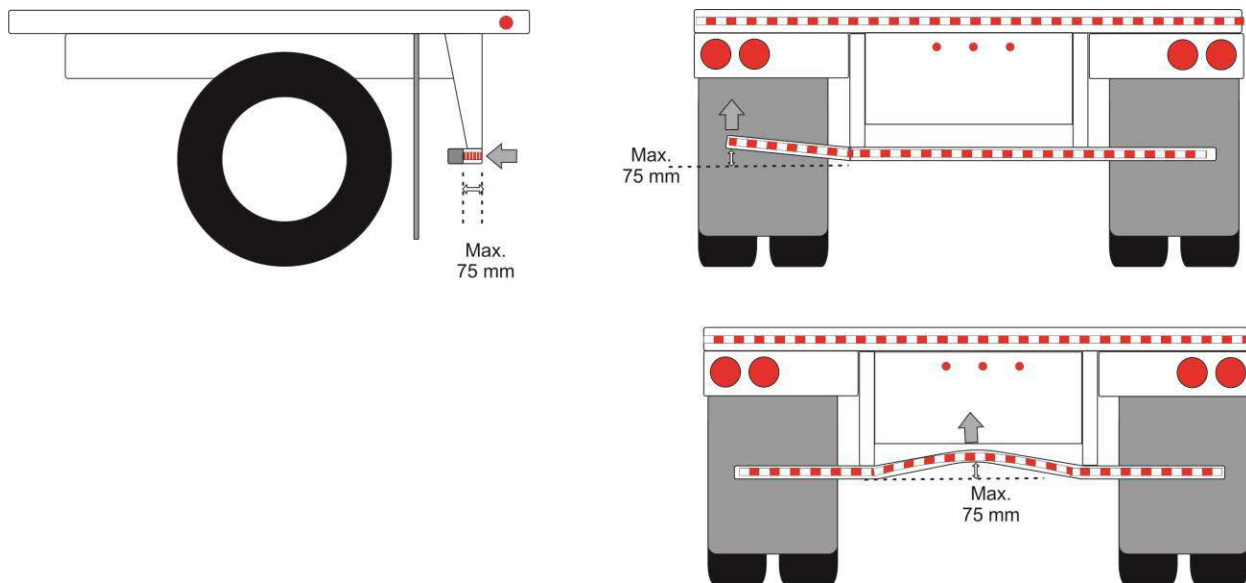
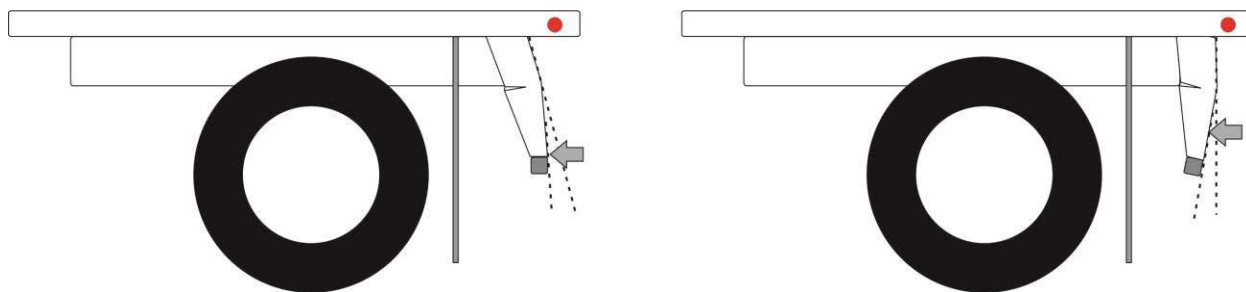

Figure 3 – Example of Damaged Vertical RIG member



Hazardous Condition(s)

- i. any part of the RIG is so *insecure* or *loose* it is likely to become detached from the vehicle

Note: All inspection procedures are visual unless additional inspection procedures are indicated. Conditions shown *in this manner* are defined conditions. The definitions can be found in the introduction section.

ITEM AND METHOD OF INSPECTION:	REJECT IF:
<u>26. Floor Pan/Baggage Floor/Step Well on a Bus</u>	NOT APPLICABLE TO TRAILERS
<u>27. Interior Body and Fixtures on a Bus</u>	NOT APPLICABLE TO TRAILERS
<u>28. Service and Exit Door on a Bus</u>	NOT APPLICABLE TO TRAILERS
<u>29. Emergency Exit (Door, Window and Roof Hatch) on a Bus</u>	NOT APPLICABLE TO TRAILERS
<u>30. Passenger Compartment Window on a Bus (Except Emergency Exit Window)</u>	NOT APPLICABLE TO TRAILERS
<u>31. School Bus Exterior Mirror (Except Standard Left and Right Side Mirror)</u>	NOT APPLICABLE TO TRAILERS
<u>32. Passenger Seat on a Bus</u>	NOT APPLICABLE TO TRAILERS
<u>33. School Bus Body Exterior</u>	NOT APPLICABLE TO TRAILERS
<u>34. Auxiliary Compartment on a Bus</u>	NOT APPLICABLE TO TRAILERS

Note: All inspection procedures are visual unless additional inspection procedures are indicated. Conditions shown *in this manner* are defined conditions. The definitions can be found in the introduction section.

Section 9 – Tires and Wheels

ITEM AND METHOD OF INSPECTION:	REJECT IF:
<p>1. Tire Tread Depth</p> <p><i>Additional Inspection Procedure(s):</i> Inspect the tire tread to locate the area where the tread depth is lowest. Measure the tread depth at a major tread groove using a suitable tread depth gauge. <u>Do not</u> measure tread depth on a wear bar.</p> <p>Tread depth measurements are to be recorded on an inspection report. The tread depth that is recorded must reflect the lowest tread depth measurement used to determine pass/fail condition.</p> <p><i>Note:</i> When any tire is replaced after a failed-inspection, the tread depth of both the original ('before') and replacement ('after') tire(s) are to be recorded.</p> <p>A "major tread groove" is one of several of the deepest moulded grooves around a tire through the full thickness of tread rubber that include wear bars.</p>	
<p>a) front tire</p>	<p>a) NOT APPLICABLE TO TRAILERS</p>
<p>b) rear tire</p> <p><i>Note:</i> Some jurisdictions require tread depth on certain vehicles to be at least 3 mm on all tires. Inspect according to <i>applicable requirements</i>.</p>	<p>b) tread depth is less than 2 mm</p>
	<p><u>Hazardous Condition(s)</u></p> <p>i. tread depth is less than 2 mm on a front tire</p> <p>ii. tread depth is less than 1 mm on a rear tire</p>
<p>2. Tire Tread Condition</p>	
<p>a) retread (re-capped or rebuilt tire) installation</p> <p><i>Note:</i> An active steering axle is one that is directly controlled by the steering wheel. A passive steering axle responds to lateral force to turn wheels.</p>	<p>a) retreaded tire is installed on an active steering axle</p>
<p>b) retread condition</p>	<p>b) retread material is <i>loose, missing</i>, or separated at the interface where the retread is bonded to the tire casing</p>

Note: All inspection procedures are visual unless additional inspection procedures are indicated. Conditions shown ***in this manner*** are defined conditions. The definitions can be found in the introduction section.

ITEM AND METHOD OF INSPECTION:	REJECT IF:
c) tread condition	c) crack or cut, that is greater than 25 mm long, that extends deeper than a major tread groove crack or cut, extends into body cord, or any body cord is exposed any piece of original tire tread is <i>missing</i> and the longest dimension across the missing section is greater than 25 mm
d) regrooving	d) regrooving has been performed on a tire <u>not</u> marked “Regroovable”
	<p><u>Hazardous Condition(s)</u></p> <ul style="list-style-type: none"> i. any part of a belt, breaker strip or casing ply is visible in the tread area ii. visible bump or bulge in the tread area indicating tread separation iii. retread material is <i>loose, missing</i>, or separated at the interface where the retread is bonded to the tire casing and the longest dimension across the section is greater than 50% of the tread width iv. any piece of tire tread is <i>missing</i> and the longest dimension across the missing section is greater than 50 mm v. tire contacts any part of the vehicle
<u>3. Tire Sidewall and Manufacturer Markings</u>	
a) matching and application <i>Note:</i> <u>Nominal</u> tire size is based on the size designation and marking provided by the tire <i>manufacturer</i> . <u>Tire diameter</u> is determined by measuring the tire.	a) nominal tire size difference on an axle is greater than 25 mm dual-mounted tire diameters differ by more than 13 mm wheel/rim size does not match tire size required tire is <i>missing</i> radial tire is mixed with non-radial on an axle any tire is labelled “Not for Highway Use” or in any way that indicates the tire is <u>not</u> intended for on-road use

Note: All inspection procedures are visual unless additional inspection procedures are indicated. Conditions shown *in this manner* are defined conditions. The definitions can be found in the introduction section.

ITEM AND METHOD OF INSPECTION:	REJECT IF:
<p>b) condition</p> <p><i>Note:</i> A bulge of up to 9 mm in height, due to a sidewall repair, is acceptable. This bulge may sometimes be identified by a blue triangular label in the immediate vicinity.</p>	<p>b) ply separation is evident or body cords are exposed</p> <p>tire has a bump or bulge caused by tread or sidewall separation</p> <p>casing is broken or distorted</p> <p>presence of plug-type repair, or rubber coated or cured rubber plug is used in the sidewall</p> <p>UV degradation damage more than 3 mm deep</p>
	<p><u>Hazardous Condition(s)</u></p> <p>i. sidewall is cut or <i>damaged</i> exposing the cord</p> <p>ii. bias and radial tires are used on the same axle</p> <p>iii. visible bump or bulge in the sidewall area greater than 9 mm in height</p> <p>iv. dual tires make contact or any tire makes contact with any vehicle component</p> <p>v. rubber coated or cured rubber plugs are used in the sidewall</p> <p>vi. tire contact with any part of the vehicle</p> <p>vii. any tire is labelled «Not for Highway Use» or in any way that indicates the tire is <u>not</u> intended for on-road use</p>
<p><u>4. Tire Inflation Pressure</u></p> <p><i>Additional Inspection Procedure(s):</i> Measure tire inflation pressure using a suitable gauge. Record pressure values on the inspection report.</p> <p><i>Note:</i> If a tire fails inspection due to over/under inflation condition, it is acceptable to remove/add air prior to completing the inspection. When inflation pressure is corrected, record found ('before') and adjusted ('after') pressure values on the inspection report.</p>	
<p>a) inflation pressure</p> <p><i>Note:</i> Recommended tire inflation pressure is based on data provided by the vehicle <i>manufacturer</i>, or tire <i>manufacturer</i> relevant to tire application and load.</p>	<p>a) more than 10% above or below recommended pressure</p> <p>difference between dual-mounted tires is more than 10%</p> <p>leaking or inflation cannot be maintained within recommended pressure</p>

Note: All inspection procedures are visual unless additional inspection procedures are indicated. Conditions shown ***in this manner*** are defined conditions. The definitions can be found in the introduction section.

ITEM AND METHOD OF INSPECTION:	REJECT IF:
b) valve stem	b) cracked, <i>damaged</i> or inaccessible preventing gauging of pressure or re-inflation, or leaking valve stem cap is <i>damaged</i> or <i>missing</i>
c) tire inflation system	c) is in a condition that any part of it could be hazardous to a person, or is in danger of falling off leaking air
	<u>Hazardous Condition(s)</u> i. any tire is inflated to 50% or less of the maximum inflation pressure marked on the sidewall ii. tire is leaking iii. tire inflation system is in a condition that any part of it is hazardous to a person, or is in danger of falling off
<u>5. Wheel Hub</u>	
a) condition <i>Note:</i> Bearing fit in the hub is checked only when disassembled.	a) repaired by welding bent, broken, cracked, <i>damaged</i> or distorted bearing cup is loose in hub bore
b) bolt/stud hole	b) any bolt/stud hole is enlarged or <i>damaged</i> in a way that prevents proper fitting and retention of studs
c) wheel seal	c) <i>level 2 leak</i> of bearing lubricant from oil lubricated hub seal is allowing grease to be lost from hub seal is out of position
d) lubricant (oil lubricated) <i>Note:</i> Some hub/wheel-end assemblies use pre-set, unitized or extended service bearings, with sealed hubs. When contaminated lubricant is suspected, refer to the service literature provided by the <i>manufacturer</i> . <u>Confirm that a proper diagnosis is carried out before rejecting the vehicle, opening or disassembling this type of hub/wheel-end assembly.</u>	d) lubricant level is below indicated minimum lubricant is contaminated with moisture or metal fragments <i>level 2 leak</i> of bearing lubricant from hub or hub cap
e) lubricant (grease lubricated)	e) grease is leaking from hub hub cap is cracked, <i>loose</i> or <i>missing</i>

Note: All inspection procedures are visual unless additional inspection procedures are indicated. Conditions shown ***in this manner*** are defined conditions. The definitions can be found in the introduction section.

ITEM AND METHOD OF INSPECTION:	REJECT IF:
	<p><u>Hazardous Condition(s)</u></p> <ul style="list-style-type: none"> i. any condition that exposes the internal components ii. any evidence of overheating of the hub or lubricant iii. lubricant not visible or measurable in hub iv. wheel seal is leaking and contaminating the tire or the brake friction material or surface
<p><u>6. Wheel Bearing</u></p> <p><i>Additional Inspection Procedure(s):</i> Check wheel bearing with axle raised sufficiently to rotate the wheel and hub assembly.</p> <p>Rotate the wheel by hand through several full revolutions to check for bearing roughness or binding.</p> <p>Check wheel bearing end-play/adjustment by pushing wheel assembly or hub inward and outward parallel to axle centreline.</p> <p><i>Note:</i> Checking in this manner may reveal movement in the hub and bearing that is additional to the bearing axial end play, e.g. a radial play between the bearings and spindle components may also be felt.</p> <p>Confirm bearing axial end-play/adjustment on a non-sealed type hub with dial gauge if necessary. For pre-set, unitized or extended service bearings see additional note.</p> <p><i>Note:</i> Some hub/wheel-end assemblies use pre-set, unitized or extended service bearings, with sealed hubs. When there is evidence of bearing damage, excessive wear, or excessive bearing end play, refer to the service literature provided by the <u>manufacturer</u>. <u>Confirm that a proper diagnosis is carried out before rejecting the vehicle, opening or disassembling this type of hub/wheel-end assembly.</u></p>	
<p>a) axial end play/adjustment</p>	<p>a) does <u>not</u> meet <i>OEM standard</i> or <i>industry standard</i>, or when specification is not provided, is less than 0.02 mm, or more than 0.13 mm</p> <p>0.02 mm = 0.001 in., 0.13 mm = 0.005 in.</p>
<p>b) condition</p>	<p>b) binding or roughness is detected while rotating the bearing</p>

Note: All inspection procedures are visual unless additional inspection procedures are indicated. Conditions shown ***in this manner*** are defined conditions. The definitions can be found in the introduction section.

ITEM AND METHOD OF INSPECTION:	REJECT IF:
c) locking device <u>Optional Inspection Procedure(s):</u> Must be inspected when the locking device is visually accessible at the time of inspection.	c) bearing adjustment locking device is <i>missing</i> , <i>not</i> engaged or non-functional
d) damage <u>Optional Inspection Procedure(s):</u> Must be inspected when the bearing is disassembled at the time of inspection.	d) race or roller is <i>damaged</i> or shows evidence of overheating
e) spindle or axle stub <u>Optional Inspection Procedure(s):</u> Must be inspected when the bearing is disassembled at the time of inspection. <i>Note:</i> Spindle or axle stub cracks or damage may involve non-destructive test/inspection to detect.	e) bearing fit onto spindle or axle stub does <i>not</i> meet OEM standard or industry standard spindle or axle stub is cracked, or <i>damaged</i> in a way that does <i>not</i> meet <i>OEM standard</i> or <i>industry standard</i> bearing condition or fit of the bearing onto the spindle prevents proper end play or adjustment from being maintained
	<u>Hazardous Condition(s)</u> i. axial end play is so excessive that imminent failure seems likely ii. any evidence of overheating iii. lubricant not visible or measurable in hub iv. binding or roughness is detected while rotating the bearing
<u>7. Wheel/Rim (Applies to all wheel types)</u>	
a) condition	a) wheel/rim is bent, broken, cracked, <i>damaged</i> or distorted wheel/rim has been welded or repaired in a way that does <i>not</i> meet <i>OEM standard</i> wheel/rim is <i>damaged</i> or discoloured as a result of heating
b) matching	b) wheel/rim size does <i>not</i> match tire size
	<u>Hazardous Condition(s)</u> i. wheel/rim, or any weld, is broken or cracked ii. any welded repair on an aluminum wheel iii. wheel/rim has been welded or repaired in a way that does not meet <i>OEM standard</i>

Note: All inspection procedures are visual unless additional inspection procedures are indicated. Conditions shown ***in this manner*** are defined conditions. The definitions can be found in the introduction section.

ITEM AND METHOD OF INSPECTION:	REJECT IF:
8. Multi-Piece Wheel/Rim	
a) condition	a) a component is bent, cracked, <i>damaged</i> , distorted, improperly assembled or shifted out of position, severely corroded or pitted <i>damaged</i> due to heating any component has been <i>repaired by welding</i>
b) lock ring	b) there is less than 3 mm clearance between butt ends of the lock ring
c) matching	c) mismatched wheel/rim component
	<u>Hazardous Condition(s)</u> i. a lock ring is bent, broken, cracked, sprung, mismatched or improperly seated ii. wheel/rim, or any weld, is broken or cracked iii. wheel/rim has been welded or repaired in a way that does <u>not meet OEM standard</u>
9. Spoke Wheel/Demountable Rim System	
a) condition <i>Additional Inspection Procedure(s):</i> Elevate the axle so that the tire(s) are clear of the floor and rotate the wheel(s) to check alignment.	a) there is damage in the 28° mounting area resulting from rim slippage, wear, corrosion or pitting there is evidence of rim slippage or incorrect positioning of rim on spokes lateral run-out exceeds 6 mm at sidewall of tire
b) rim clamp	b) any rim clamp is broken, cracked, <i>missing</i> , repaired by welding, mismatched, twisted or worn out in the 28° mounting area any heelless clamp is bottomed or gap between clamp and spoke is more than 10 mm gap between clamp and spoke of a heel type clamp is more than 6 mm
c) spacer band	c) any spacer is collapsed, cracked, distorted, <i>missing</i> , the incorrect size or type, welded or repaired in a way that does <u>not meet OEM standard</u>
	<u>Hazardous Condition(s)</u> i. wheel/rim, or any weld, is broken or cracked ii. any welded repair on an aluminum wheel iii. wheel/rim has been welded or repaired in a way that does <u>not meet OEM standard</u>

Note: All inspection procedures are visual unless additional inspection procedures are indicated. Conditions shown *in this manner* are defined conditions. The definitions can be found in the introduction section.

ITEM AND METHOD OF INSPECTION:	REJECT IF:
10. Disc Wheel System	
a) installation	a) incompatible wheel or component is used on a wheel system wheel is incorrectly installed
b) condition	b) there is evidence of a <i>loose</i> or ineffective fastener there is evidence of damage or deterioration, foreign material, excessive or uncured paint on a hub, drum or wheel mounting face bolt/stud hole is elongated
	<u>Hazardous Condition(s)</u> i. bolt/stud hole is elongated ii. wheel/rim, or any weld, is broken or cracked iii. any welded repair on an aluminum wheel iv. wheel/rim has been welded or repaired in a way that does not meet <i>OEM standard</i>
11. Wheel Fasteners (Nuts, Bolts and Studs)	
a) installation	a) incorrect fastener type, thread direction or style is installed any nut is <i>not</i> fully engaged with the stud or bolt
b) condition	b) any fastener is bent, broken, <i>damaged</i> or <i>missing</i>
c) fastener security <i>Additional Inspection Procedure(s):</i> Using a torque wrench set to the torque value specified by <i>OEM</i> or <i>industry standard</i> , attempt to rotate each wheel nut to the set value. <i>Note:</i> A fastener that requires <i>less</i> than 1/6-turn to reach the specified torque value should be considered <i>slightly loose</i> . A fastener that requires <i>more</i> than 1/6- turn to reach the specified torque value should be considered <i>very loose</i> . Wheels should be disassembled for a full inspection when: • any fastener is <i>very loose</i> • two adjacent wheel fasteners are <i>slightly loose</i> • three wheel fasteners on a single wheel are <i>slightly loose</i>	c) any fastener rotates before the torque value specified by <i>OEM standard</i> or <i>industry standard</i> is applied
	<u>Hazardous Condition(s)</u> i. wheel is <i>loose</i> ii. any wheel nut or stud is broken, cracked, <i>loose</i>, <i>missing</i>, or threads are stripped

Note: All inspection procedures are visual unless additional inspection procedures are indicated.

Conditions shown ***in this manner*** are defined conditions. The definitions can be found in the introduction section.

Section 10 – Coupling Devices

ITEM AND METHOD OF INSPECTION:	REJECT IF:
<p><u>1. Hitch Assembly, Structure and Attaching Components</u></p> <p><i>Note:</i> This applies to <u>all types</u> of hitching systems and coupling devices.</p> <p>Some rust and corrosion on the outer surface of exposed metal parts is normal. When an excessive amount of rust or corrosion is present and has visibly reduced the thickness of the material, structural deterioration is possible.</p> <p><i>Additional Inspection Procedure(s):</i> Inspect using suitable tools.</p>	
<p>a) hitch assembly, receiver, drawbar or draw beam, slider, supporting structure and attachment to vehicle chassis</p>	<p>a) part is bent, broken or cracked</p> <p>weld is broken or cracked</p> <p>welded or repaired in a way that does <u>not</u> meet <i>OEM standard</i></p> <p>fastener is ineffective, <i>loose</i> or <i>missing</i></p> <p>any part of hitch assembly is worn beyond <i>manufacturer</i> specifications, abnormally deteriorated or perforated by corrosion</p> <p>hinged drawbar bushing is worn beyond <i>manufacturer</i> specifications</p> <p>air leak, or <i>level 2 leak</i> from hydraulic components on any slider system</p> <p>any slider system has a <i>missing</i> or ineffective stop</p>
	<p><u>Hazardous Condition(s) (when in use)</u></p> <p>i. any crack, break or damage in the stress or loading area of the coupling device or structure</p> <p>ii. any component is <i>damaged</i> or worn to the degree that it is no longer effective</p> <p>iii. welded or repaired in a way that does <u>not</u> meet <i>OEM standard</i> and an imminent failure appears likely</p> <p>iv. air leak, or <i>level 2 leak</i> from hydraulic components on any slider system</p> <p>v. any slider system has a <i>missing</i> or ineffective stop</p>

Note: All inspection procedures are visual unless additional inspection procedures are indicated. Conditions shown ***in this manner*** are defined conditions. The definitions can be found in the introduction section.

ITEM AND METHOD OF INSPECTION:	REJECT IF:
<u>2. Secondary Attachment (Safety Chain or Cable)</u>	
a) condition	a) bent, broken, cracked, <i>missing</i> , <i>abnormally worn</i> , or worn beyond <i>manufacturer</i> specifications any part is ineffective, <i>insecure</i> , <i>loose</i> , or <i>missing</i> improper length
	<u>Hazardous Condition(s) (when in use)</u> i. any component is broken, cracked, or <i>missing</i> ii. bent, <i>damaged</i>, improperly repaired, <i>loose</i>, or worn to the degree that it is no longer effective iii. improper type or inadequate capacity
<u>3. Pintle Hook, Pin Hitch, or Coupler Hitch</u>	
a) condition and operation <i>Additional Inspection Procedure(s):</i> Test the operation of the pintle hook and latch.	a) cracked, or fails to close or latch normally
b) mounting	b) fastener or any structural part is cracked, ineffective, <i>loose</i> or <i>missing</i> a fastener is less than SAE grade 8 or ISO class 10.9
c) cast or forged part	c) cracked, or has been repaired by welding material is worn more than 5 mm from original dimension
d) air chamber cushion (no-slack or snubber) <i>Additional Inspection Procedure(s):</i> Apply air pressure to air chamber and inspect according to hitch <i>manufacturer</i> service instructions and specifications.	d) <i>damaged</i> or leaking air chamber leak at air line or fitting pressure protection valve is not installed in air supply to prevent depletion of air from the brake system
e) lunette (or drawbar eye) <u>on trailer</u>	e) cracked, or is worn more than 5 mm from original dimension
	<u>Hazardous Condition(s) (when in use)</u> i. wear on hitch or lunette (eye) exceeds 10 mm ii. any component is broken, cracked, or <i>missing</i> iii. bent, <i>damaged</i>, improperly repaired, <i>loose</i>, or worn to the degree that it is <u>no longer</u> effective iv. improper type or inadequate capacity v. missing or ineffective fastener vi. insecure latch

Note: All inspection procedures are visual unless additional inspection procedures are indicated. Conditions shown *in this manner* are defined conditions. The definitions can be found in the introduction section.

ITEM AND METHOD OF INSPECTION:	REJECT IF:
<u>4. Ball Type Hitch</u>	
a) ball, neck and stem	a) bent, cracked or <i>loose</i> ball is worn more than 3.0 mm from original dimension welded, or repaired in a way that does <u>not</u> meet <i>OEM standard</i> 3.0 mm = 0.12 in.
b) ball deck area	b) part is bent, broken or cracked weld is broken or cracked welded or repaired in a way that does <u>not</u> meet <i>OEM standard</i>
c) ball coupler	c) bent, cracked or <i>loose</i> abnormally deteriorated or perforated by corrosion
d) latch <i>Additional Inspection Procedure(s):</i> Test the operation of the latch.	d) bent, broken or cracked <i>inoperative</i> or fails to adjust properly weld is broken or cracked
<p><u>Hazardous Condition(s) (when in use)</u></p> <ul style="list-style-type: none"> i. wear on ball exceeds 3.0 mm ii. any component is broken, cracked, or <i>missing</i> iii. bent, <i>damaged</i>, improperly repaired, <i>loose</i>, or worn to the degree that it is <u>no longer</u> effective iv. improper type or inadequate capacity v. missing or ineffective fastener vi. insecure latch 	
<u>5. Roll-Coupling Hitch</u>	
a) condition	a) part is bent, broken or cracked weld is broken or cracked welded or repaired in a way that does <u>not</u> meet <i>OEM standard</i> fastener is ineffective, <i>loose</i> or <i>missing</i> any fastener is smaller than specified by the <i>manufacturer</i> or less than SAE grade 8 or ISO class 10.9 any load bearing structural part of the hitch assembly is deteriorated or perforated by corrosion

Note: All inspection procedures are visual unless additional inspection procedures are indicated. Conditions shown *in this manner* are defined conditions. The definitions can be found in the introduction section.

ITEM AND METHOD OF INSPECTION:	REJECT IF:
b) operation <i>Additional Inspection Procedure(s):</i> Test the operation of the coupling and controls according to the <u>manufacturer</u> service instructions.	b) <u>fails to operate</u> in the intended manner
	<p><u>Hazardous Condition(s) (when in use)</u></p> <ul style="list-style-type: none"> i. fails to operate in the intended manner ii. any component is broken, cracked, or <i>missing</i> iii. bent, <i>damaged</i>, improperly repaired, or <i>loose</i> iv. improper type or inadequate capacity v. missing or ineffective fastener
<p><u>6. Automated Coupling Device</u></p>	
a) condition <i>Additional Inspection Procedure(s):</i> Test the operation of the coupler according to the <u>manufacturer</u> service instructions.	a) <u>inoperative</u> <ul style="list-style-type: none"> • welded or repaired in a way that does <u>not</u> meet manufacturer standard
	<p><u>Hazardous Condition(s) (when in use)</u></p> <ul style="list-style-type: none"> i. fails to operate in the intended manner ii. any component is broken, cracked, or <i>missing</i> iii. bent, <i>damaged</i>, improperly repaired, <i>loose</i>, or worn to the degree that it is no longer effective iv. improper type or inadequate capacity v. <i>missing</i> or ineffective fastener
<p><u>7. Fifth Wheel Coupler</u></p>	
a) upper coupler (pick up plate) <u>on trailer</u> <i>Additional Inspection Procedure(s):</i> Check the condition and flatness of the upper coupler plate using a tool specifically intended for that purpose or an equivalent measuring device.	a) cracked, <u>loose</u> , warped or worn so that the area in contact with the lower fifth wheel is less than 75% of the surface of the lower coupler bent upward or downward more than specified by <u>manufacturer</u> lubricant is contaminated with an abrasive material upper coupler's attachment or a structural member is corroded, <u>damaged</u> or in a condition that the plate or king pin is weakened mounting bolt or rivet is broken, corroded, <u>loose</u> or <u>missing</u> (also refer to Section 8, Body, item 6. Frame, Rails & Mounts) bulge is present in attaching and mating surface due to corrosion rivet is dimpled due to corrosion rivet area bulged due to corrosion

Note: All inspection procedures are visual unless additional inspection procedures are indicated. Conditions shown in this manner are defined conditions. The definitions can be found in the introduction section.

ITEM AND METHOD OF INSPECTION:	REJECT IF:
<p>b) kingpin <u>on trailer</u> (or on towing vehicle)</p> <p><i>Additional Inspection Procedure(s):</i> Check the wear and condition of the kingpin using a gauge specifically intended for that purpose or an equivalent measuring device.</p> <p><i>Note:</i> In some jurisdictions remanufacturing of kingpins is permitted when the remanufacturing is done using a process certified by a professional engineer. In such a case the kingpin must be permanently marked to identify the remanufacturer and marked to indicate the date the process was completed.</p>	<p>b) bent, broken, cracked, deformed or <i>loose</i></p> <p>worn more than 3.0 mm</p> <p>repaired by welding</p> <p>length is incorrect to properly fit into fifth wheel jaws</p> <p><i>Note:</i> A fifth wheel intended for use with a material installed on the lower coupler, instead of applying grease, requires a longer king pin length.</p> <p>A king pin intended for use with a material installed on the lower coupler, instead of applying grease, <i>does not</i> properly couple with a standard fifth wheel.</p>
<p>c) lower coupler (fifth wheel) top plate</p>	<p>c) any part is broken, cracked, <i>damaged</i>, distorted, <i>missing</i> or welded, or repaired in a way that does <i>not</i> meet <i>manufacturer</i> standard</p> <p>surface is worn beyond <i>manufacturer</i> specified limit</p> <p>wear in pivot pin is beyond <i>manufacturer</i> specified limit</p> <p>lubricant is abnormally contaminated, (e.g. sand, gravel)</p> <p>not properly lubricated (unless equipped with <i>manufacturer-supplied</i> no-lube top plate coupling surface)</p>
<p>d) latching mechanism</p> <p><i>Additional Inspection Procedure(s):</i> Test the operation of the latch, and wear in the fifth wheel assembly, using a test device specifically designed for that purpose or a suitable equivalent.</p>	<p>d) broken, cracked or <i>inoperative</i></p> <p>stiffness or seizing of the latch mechanism is felt</p> <p>free-play, slack or wear is beyond manufacturer specified limit</p> <p>improperly adjusted</p> <p>modified or improperly repaired</p> <p>release handle is bent, modified or has anything attached to it</p>
<p>e) lower coupler pivot ('fifth wheel saddle')</p> <p><i>Additional Inspection Procedure(s):</i> Check for wear in the fifth wheel pivot area according to <i>manufacturer</i> service instructions.</p>	<p>e) wear exceeds <i>manufacturer</i> specification</p>

Note: All inspection procedures are visual unless additional inspection procedures are indicated. Conditions shown ***in this manner*** are defined conditions. The definitions can be found in the introduction section.

ITEM AND METHOD OF INSPECTION:	REJECT IF:
f) slider assembly and locking mechanism	f) any part is bent, broken, cracked, <i>damaged</i> or <i>inoperative</i> fore/aft movement of fifth wheel in slider exceeds <i>manufacturer</i> specification fails to lock securely slider stop is <i>missing</i> or <i>insecure</i>
g) air-operated control or feature	g) does not <i>operate as intended</i> by the <i>manufacturer</i>
h) upper and lower coupler attachment to frame	h) any part is broken, cracked, <i>damaged</i> , distorted, <i>missing</i> , or welded or repaired in a way that does <u>not</u> meet <i>manufacturer</i> standard any fastener is cracked, ineffective, <i>loose</i> or <i>missing</i> fasteners used to attach coupler assembly to frame <u>do not</u> meet the minimum requirements shown in the table below:

Minimum Number of Bolts per Side Based on Type & Size* of Bolt						
Maximum trailer GVWR	ASTM A325 Type 1,2 & 3 (metric 5.8)		SAE J429 Grade 5 (metric 8.8)		SAE J429 Grade 8 (metric 10.9)	
	1/2" (12mm)	5/8" (16mm) or larger	1/2" (12mm)	5/8" (16mm) or larger	1/2" (12mm)	5/8" (16mm) or larger
67,999 lb (30,845 kg) or less	6	4	6	4	5	4
68,000 - 84,999 lbs (30,846 - 38,556 kg)	8	5	8	5	7	5
85,000 - 105,000 lbs (38,557 - 47,628 kg)	10	6	10	6	8	5
<p>*Bolt size refers to the outside diameter of the thread.</p> <ul style="list-style-type: none"> • 1/2 inch bolts have 3/4 inch heads and nuts • 5/8 inch bolts have 15/16 inch heads and nuts • 12 mm bolts have 19 mm heads and nuts • 16 mm bolts have 24 mm inch heads and nuts 						

Note: All inspection procedures are visual unless additional inspection procedures are indicated. Conditions shown *in this manner* are defined conditions. The definitions can be found in the introduction section.

ITEM AND METHOD OF INSPECTION:	REJECT IF:
	<p><u>Hazardous Condition(s) (when in use)</u></p> <ul style="list-style-type: none"> i. adjustable fifth wheel has 25% or more of the locking pins <i>missing</i> ii. any observable movement between the fifth wheel, or upper coupler, mounting components and/or the frame iii. more than 9 mm fore/aft movement of the fifth wheel in its sliding track iv. any sliding fifth wheel locking mechanism does not remain in the locked position v. any crack, break or damage in the stress or loading area of the coupling device vi. slider stop is <i>insecure</i> or <i>missing</i> vii. more than 25 percent of latching fasteners on either side of slider are ineffective viii. pivot bracket pin <i>missing</i> or not secured ix. any parent metal cracked x. any repair weld cracking, well defined (especially open) cracks in stress or load-bearing areas, cracks through 20% or more original welds or parent metal xi. operating handle not in closed or locked position xii. more than 20 percent of mounting fasteners on either side <i>missing</i> or ineffective xiii. locking mechanism parts broken, <i>missing</i>, or deformed to the extent that the kingpin is not securely held xiv. kingpin is bent, broken, cracked, deformed or <i>loose</i> xv. any trailer with a bolted upper coupler, which has fewer effective bolts than shown in table above
<p><u>8. Oscillating Fifth Wheel Coupler</u></p> <p><i>Note:</i> Inspect fifth wheel coupler parts as described above in item 6, and inspect additional oscillating items as listed below. Inspect all frame and structural elements as described above in item 1.</p>	
<p>a) oscillating components and structure</p> <p><i>Additional Inspection Procedure(s):</i> Check for wear and defects according to <u>manufacturer</u> service instructions.</p>	<p>a) cracked, <i>damaged</i>, defective or <i>inoperative</i> wear exceeds <u>manufacturer</u> specification</p>
	<p><u>Hazardous Condition(s) (when in use)</u></p> <p>refer to hazardous conditions in item # 7 above.</p>

Note: All inspection procedures are visual unless additional inspection procedures are indicated. Conditions shown ***in this manner*** are defined conditions. The definitions can be found in the introduction section.

ITEM AND METHOD OF INSPECTION:	REJECT IF:
<p><u>9. Ball-Bearing Type Turntable on Trailer</u></p> <p>a) condition</p> <p><i>Additional Inspection Procedure(s):</i> Check for wear and defects according to <u>manufacturer</u> service instructions.</p>	<p>a) bolt <i>loose</i> or <i>missing</i></p> <p>cracks in weld or parent metal</p> <p>wear exceeds <u>manufacturer</u> specification</p>
	<p><u>Hazardous Condition(s)</u></p> <p>i. top flange has less than 6 effective bolts</p> <p>ii. bottom flange has less than 6 effective bolts</p> <p>iii. itwenty percent or more of original welds (or repaired original welds), or parent metal cracked</p> <p>iv. upper flange half touching lower flange half</p> <p>v. cracked flanges</p>

Note: All inspection procedures are visual unless additional inspection procedures are indicated. Conditions shown ***in this manner*** are defined conditions. The definitions can be found in the introduction section.

Appendix A

ITEM AND METHOD OF INSPECTION:	REJECT IF:
<u>1. Liquefied Petroleum Gas (LPG or Propane) Fuel System</u>	
<p><i>Note:</i> For additional compliance information, please see Canadian Gas Association Code.</p>	<p>Hazardous Condition Any cause for rejection of a Liquefied Petroleum Gas (LPG or Propane) system will also mean an automatic “Hazardous Condition” for that vehicle. The cause for rejection must be corrected and the vehicle “passed” before it may be operated on the highway.</p>
<p>a) regulatory authority decal</p>	<p>a) decal is <u>not</u> displayed an incorrect decal is affixed to vehicle information on decal is <u>not</u> readable</p>
<p>b) pressure vessel (tank) location and mounting</p>	<p>b) pressure vessel (tank) is <i>insecure</i> or <i>loose</i>, or welds are broken welding has been done anywhere on a pressure vessel (tank) except on saddle plates or brackets correct mounting bolts <u>not</u> used correct reinforcing plates are <u>not</u> used under mounting nuts pressure vessel (tank) is located above the vehicle or projects beyond vehicle side, ahead of front axle or behind rear bumper any part of exhaust system is closer than 200 mm to any part of the fuel system and is <u>not</u> protected by shields a heat shield is closer than 25 mm from a fuel system component</p>
<p>c) pressure vessel (tank) ground clearance</p> <p><i>Note:</i> Includes any attached fitting.</p>	<p>c) distance to ground from bottom of pressure vessel (tank) is less than minimum ground clearance shown below</p> <p>pressure vessel (tank) located between axles wheelbase of 3220 mm <u>or less</u>: minimum ground clearance = 180 mm wheelbase <u>over</u> 3220 mm: minimum ground clearance = 230 mm</p> <p>pressure vessel (tank) located behind rear axle minimum ground clearance = 200 mm</p> <p>Any portion of the tank protrudes past the plane formed by the bottom of the rear most tires and the lowest most rearward part of the vehicle.</p>

Note: All inspection procedures are visual unless additional inspection procedures are indicated. Conditions shown *in this manner* are defined conditions. The definitions can be found in the introduction section.

ITEM AND METHOD OF INSPECTION:	REJECT IF:
d) pressure vessel (tank) information plate and data	d) name plate is <i>missing</i> , or illegible, or data is <u>not</u> shown on plate
e) pressure vessel (tank) located within the body shell of the vehicle	e) stop fill valve, remote fill, or gauging line <u>not</u> fitted
f) pressure vessel (tank) filler cap	f) protective filler cap <u>not</u> secured to filler valve or vehicle
g) pressure vessel (tank) check valve	g) double check valve on the remote fill is <i>missing</i> , or valve is <u>not</u> an approved type
h) pressure vessel (tank) interconnection	h) individual pressure vessels (tanks) are <u>not</u> protected by soft seat back-check valves
i) pressure vessel (tank) remote filler box	i) <u>not</u> adequately sealed to prevent vapour migration into vehicle interior (trunk etc.)
j) main shut-off valve	j) valve is <u>not</u> readily accessible (<u>cannot</u> be reached)
k) damage protection	k) tank valves and their connections are <u>not</u> mounted securely tank valves and their connections are <u>not</u> protected from damage due to stationary objects, or objects from the road
l) corrosion protection	l) protective coating or material is <i>damaged</i> , or is <i>missing</i> from externally mounted pressure vessel (tank) or attachment
<p>m) fitting, hose, piping and tubing</p> <p><i>Note:</i> Only the following types of piping and tubing are permitted for use in LPG fuel systems.</p> <p><u>Piping</u> – must be black or galvanized steel w/ steel fittings (schedule 40 vapour and schedule 80 liquid)</p> <p><u>Tubing</u> – must meet SAE J527, may be steel or copper with steel or brass fittings</p> <p>Minimum tubing wall thickness: ¼ in. tubing = 0.71 mm ½ in. tubing = 0.76 mm</p>	<p>m) improper tubing or piping is used</p> <p>hose assembly is <u>not</u> CGA approved and labelled</p> <p>supply line is <u>not</u> secure, or any anchor or support is damaged or missing</p> <p>any joint is not flared or compression type specifically designed for LPG use</p> <p>a bushing other than steel or brass is used</p> <p>piping and tubing is <u>not</u> protected against corrosion</p> <p>tubing or hose in trunk area is <u>not</u> protected against luggage</p> <p>piping between fuel pump and gasoline solenoid valve is non-metallic material</p>

Note: All inspection procedures are visual unless additional inspection procedures are indicated.

Conditions shown *in this manner* are defined conditions. The definitions can be found in the introduction section.

ITEM AND METHOD OF INSPECTION:	REJECT IF:
n) system leakage <i>Additional Inspection Procedure(s):</i> Check for leaks using a leak detector.	n) any system leak is detected
o) hydrostatic relief valve	o) incorrectly installed or <i>missing</i> outlet is <u>not</u> piped downward to outside of any enclosed space pipeaway is <u>not</u> secured to valve, or if installed after May 1, 1985, is aluminum or non-metallic material, or is a range connector type
p) propane supply lock off valve	p) does <u>not</u> operate as originally intended
q) excess flow valve	q) incorrectly installed or <i>missing</i>
r) vaporizer	r) is <u>not</u> mounted securely on engine, chassis, fender apron or firewall
s) vehicle chassis and under-body	s) a structural member has been altered during installation of the system in any manner that does <u>not</u> meet <i>industry standard</i> or <i>OEM standard</i>
t) pressure vessel sub-frame	t) any modification has been made to pressure vessel (tank) carrier, or sub-frame, in a manner <u>not</u> approved by pressure vessel <i>manufacturer</i>
u) air/fuel ratio feedback control system <i>Note:</i> Applies to a vehicle originally equipped with air/fuel ratio control, converted to operate on LPG on or after October 1993, as indicated on the regulatory authority decal. <i>Additional Inspection Procedure(s):</i> Connect the positive lead of a digital voltmeter to the O ₂ sensor signal wire. Connect the meter negative lead to battery ground. Start the engine and run at 2,500 RPM allowing 30 seconds to warm up the O ₂ sensor, voltage should vary rapidly between 0.3 and 0.7 volts. Each time the voltage reading crosses 0.45 volts is defined as one cross-count. On dual fuel applications this test must be performed when operating on both fuels.	u) The number of cross-counts observed during a ten-second period is less than 6

Note: All inspection procedures are visual unless additional inspection procedures are indicated. Conditions shown *in this manner* are defined conditions. The definitions can be found in the introduction section.

ITEM AND METHOD OF INSPECTION:	REJECT IF:
2. Compressed Natural Gas (CNG) Fuel System	
<p><i>Note:</i> For additional compliance information, see Canadian Gas Association Code.</p>	<p>Hazardous Condition</p> <p>Any cause for rejection of a Compressed Natural Gas system will also mean an automatic “Hazardous Condition” for that vehicle. The cause for rejection must be corrected and the vehicle “passed” before it may be operated on the highway.</p>
a) regulatory authority decal	<p>a) decal is <u>not</u> displayed</p> <p>an incorrect decal is affixed to vehicle</p> <p>information on decal is <u>not</u> readable</p>
b) pressure vessel (tank) location and mounting	<p>b) pressure vessel (tank) is <i>insecure</i> or <i>loose</i>, or welds are broken</p> <p>welding has been done anywhere on a pressure vessel except on saddle plates or brackets</p> <p>correct mounting bolts <u>not</u> used (10 mm (3/8 in.) for over 100L tank capacity)</p> <p>correct reinforcing plates are <u>not</u> used under mounting nuts</p> <p>pressure vessel (tank) is located above the vehicle or projects beyond vehicle side, ahead of front axle or behind rear bumper</p> <p>any part of exhaust system is closer than 200 mm from any part of the fuel system and is <u>not</u> protected by shields</p> <p>a heat shield is closer than 25 mm from a fuel tank</p>
<p>c) pressure vessel (tank) ground clearance</p> <p><i>Note:</i> Includes any attached fitting.</p>	<p>c) distance to ground from bottom of pressure vessel (tank) is less than minimum ground clearance shown below</p> <p>pressure vessel (tank) located <u>between axles</u></p> <p>wheelbase of 3220 mm <u>or less</u>: minimum ground clearance = 180 mm</p> <p>wheelbase <u>over</u> 3220 mm: minimum ground clearance = 230 mm</p> <p>pressure vessel (tank) located <u>behind rear axle</u></p> <p>distance from rear axle to pressure vessel (tank) is 1140 mm <u>or less</u>: minimum ground clearance = 200 mm</p> <p>distance from rear axle to pressure vessel (tank) is <u>more than</u> 1140 mm: minimum ground clearance = 0.18 x distance</p>
d) pressure vessel (tank) information plate and data	d) name plate is <i>missing</i> , or illegible, or data is <u>not</u> shown on plate
e) pressure vessel (tank) located within the body shell of the vehicle	e) tank fittings <u>not</u> in a gas-tight enclosure vented to the outside of the vehicle body shell

Note: All inspection procedures are visual unless additional inspection procedures are indicated. Conditions shown ***in this manner*** are defined conditions. The definitions can be found in the introduction section.

ITEM AND METHOD OF INSPECTION:	REJECT IF:
f) relieving device	f) pressure vessel does <u>not</u> have a burst disc installed burst disc is <u>incorrectly</u> installed, or <u>not</u> the correct value burst disc is <u>not</u> vented outside the body shell
g) damage protection	g) piping or tubing is <u>not</u> of corrosion resistant material piping or tubing is <u>not</u> protected from exterior corrosion line is <u>not</u> positioned for reasonable protection or <u>not</u> shielded grommet is <i>missing</i> or <i>damaged</i>
h) corrosion protection	h) piping or tubing is <u>not</u> made of corrosion-resistant material or is not protected from exterior location
i) pressure gauge	i) <u>no</u> gauge is installed lines to gauge are within the passenger compartment
j) fitting, hose, piping and tubing Only the following types of piping and tubing are permitted for use in LPG fuel systems. <u>Piping</u> – must be black or galvanized steel w/ steel fittings (schedule 40 vapour and schedule 80 liquid) <u>Tubing</u> – must meet SAE J527, may be steel or copper with steel or brass fittings Minimum tubing wall thickness: ¼ in. tubing = 0.71 mm ½ in. tubing = 0.76 mm	j) piping upstream of a first-stage regulator is <u>not</u> rated at 4 times working pressure, or piping downstream of first-stage regulator <u>not</u> rated at 5 times the working pressure piping, tubing and hose <u>fail to</u> make adequate allowance for vibration; is <u>not</u> protected against damage or breakage due to strain or wear a fitting <u>not</u> an approved type a joint is inaccessible improper hose, tubing or piping is used
k) system leakage <i>Additional Inspection Procedure(s):</i> Check for leaks using a leak detector.	k) any system leak is detected
l) pressure regulator	l) regulator <u>not</u> securely mounted <u>not</u> protected as required
m) gasoline lock-off	m) where located downstream of the engine fuel pump, connection of gasoline fuel line to the inlet side of lock-off valve, or any other upstream connections, <u>not</u> made with flare-type fittings or other approved fittings slip-on clamped type hose connection is used
n) vehicle chassis and under-body	n) a structural member has been altered during installation of the system in any manner that does <u>not</u> substantially meet or exceed <i>OEM</i> strength requirements
o) pressure vessel sub-frame	o) any modification has been made to pressure vessel (tank) carrier, or sub-frame, in a manner <u>not</u> approved by pressure vessel <i>manufacturer</i>

Note: All inspection procedures are visual unless additional inspection procedures are indicated. Conditions shown *in this manner* are defined conditions. The definitions can be found in the introduction section.

ITEM AND METHOD OF INSPECTION:	REJECT IF:
<p>p) air/fuel ratio feedback control system</p> <p><i>Additional Inspection Procedure(s):</i> Connect the positive lead of a digital voltmeter to the O₂ sensor signal wire. Connect the meter negative lead to battery ground. Start the engine and run at 2,500 RPM allowing 30 seconds to warm up the O₂ sensor, voltage should vary rapidly between 0.3 and 0.7 volts. Each time the voltage reading crosses 0.45 volts is defined as one cross-count.</p> <p>On dual fuel applications this test must be performed when operating on both fuels.</p>	<p>p) the number of cross-counts observed during a ten-second period is less than 6</p>
<p><u>3. Liquefied Natural Gas (LNG) Fuel System</u></p>	
<p><i>Note:</i> For additional compliance information, see Society of Automotive Engineers (SAE) Standard J2343 titled “Recommended Practice for LNG Medium and Heavy Duty Powered Vehicles”, and the National Fire Protection Association (NFPA) Standard 52 “Vehicular Gaseous Fuel Systems Code”</p>	<p>Hazardous Condition</p> <p>Any cause for rejection of a Liquefied Natural Gas (LNG) system will also mean an automatic “Hazardous Condition” for that vehicle. The cause for rejection must be corrected and the vehicle “passed” before it may be operated on the highway.</p>
<p>a) regulatory authority decal</p>	<p>a) decal is <u>not</u> visible or information on decal is <u>not</u> readable</p> <p>incorrect decal is affixed to the vehicle or fuel is <u>not</u> correctly identified</p>
<p>b) supply/container marking</p> <p><i>Note:</i> As required by National Fire Protection Association (NFPA) 52.</p>	<p>b) <i>missing</i>, <u>not</u> visible directly or by use of mirror</p> <p><u>no</u> indication of set-to-discharge pressure</p> <p><u>no</u> indication of working pressure of fuel supply</p> <p>remote filling inlets <u>not</u> visibly marked with the lowest working pressure of any fuel supply container in system</p>
<p>c) methane gas detection system</p> <p><i>Additional Inspection Procedure(s):</i> Test the system in accordance with the <i>manufacturer</i> service instructions.</p>	<p>c) disconnected, <i>inoperative</i> or <i>missing</i></p> <p>sensor is <u>not</u> located in engine, driver, and passenger compartment</p> <p>alarm is <u>not</u> visual and audible to the driver before entering the drivers compartment and while seated in the normal driving position</p> <p>system does not function continuously at all times</p>

Note: All inspection procedures are visual unless additional inspection procedures are indicated. Conditions shown ***in this manner*** are defined conditions. The definitions can be found in the introduction section.

ITEM AND METHOD OF INSPECTION:	REJECT IF:
<p>d) LNG container (all types)</p> <p><i>Note:</i> No LNG container shall be repaired unless authorized by a certified inspector.</p> <p>The replacement of valves, fittings and accessories with compliant parts intended for the same purpose is not considered a repair.</p>	<p>d) <u>not</u> oriented and mounted as specified by the <i>manufacturer</i></p> <p><u>not</u> located in a protected location as designed by the vehicle <i>manufacturer</i> or as determined by a qualified professional engineer</p> <p>any portion of the container or container valves in communication with the liquid or vapour are <u>not</u> located behind the rear frame cross member</p> <p>any part of the container is welded</p> <p><i>Note:</i> Only saddle plates, brackets or non-pressure components that were provided and installed by the <i>manufacturer</i> may be field welded.</p>
<p>e) roof-mounted LNG container</p> <p><i>Note:</i> This condition applies to a roof-mounted LNG container in addition to those listed above for all types of containers.</p>	<p>e) vehicle was <u>not</u> manufactured or originally designed to have roof mounted containers</p> <p><i>Note:</i> After-market modification of a vehicle to accept roof-mounted containers is <u>not</u> permitted.</p>
<p>f) LNG container on a bus or motor coach</p> <p><i>Note:</i> These conditions apply in addition to those listed above for all types of containers.</p>	<p>f) located in or above the passenger compartment</p> <p>container is installed so that gas from fuelling or gauging operation or from a relief valve can be released inside a driver, passenger or luggage compartment</p>
<p>g) service valve emergency access port</p>	<p>g) <u>not</u> located on vehicle sidewall</p> <p><u>not</u> hinged and latched</p> <p>is locked</p>

Note: All inspection procedures are visual unless additional inspection procedures are indicated. Conditions shown *in this manner* are defined conditions. The definitions can be found in the introduction section.

ITEM AND METHOD OF INSPECTION:	REJECT IF:
<p>h) vent line and outlet</p> <p><i>Note:</i> All safety devices that may discharge to atmosphere must be vented to the outside of the vehicle.</p>	<p>h) any safety device <u>does not</u> vent to the outside of the vehicle</p> <p>vent line is made of aluminum or copper</p> <p>discharge line port size is <u>not</u> equal or greater than the main automatic or manual shut off valve</p> <p>line installed inside a compartment does <u>not</u> extend to the outside</p> <p><u>not</u> located as far as practicable from the engine exhaust outlet</p> <p>does <u>not</u> direct escaping gas upward within 45 degrees</p> <p>escaping gas impinges fuel supply</p> <p>directed into wheel well</p> <p>directed at engine air intake inlets</p> <p>direction of escaping gas may cause a hazard to other road users</p> <p><u>not</u> at least 1.5 times the maximum allowable working pressure (MAWP) of the container they are connected to. (When discharged into a manifold or line of increased diameter, the pressure requirement of that manifold or line must be calculated by a professional engineer to determine compliance.)</p> <p>fuel exiting the vaporizer has <u>not</u> been completely converted to a gaseous state at a temperature suitable for introduction to the remainder of the fuel system as Compressed Natural Gas (CNG)</p> <p>any vent line from the LNG fuel system is combined with CNG vent line</p>
<p>i) manual shut-off valve</p> <p><i>Note:</i> Valves, valve packing, gaskets and seats must be specifically designed for LNG service.</p> <p>If a manual shut-off valve <u>cannot</u> be readily installed due to the compact design of the LNG fuel container, an automatic shut-off valve meeting section j) automatic shut-off valve can be used providing it is located downstream in the CNG portion of the fuel system.</p> <p><i>Note:</i> Decals and stencils are acceptable means of marking.</p>	<p>i) <u>not</u> installed in the outlet of the manifold</p> <p><u>not</u> suitable for the maximum allowable pressure of the container</p> <p>leakage occurs at less than 1.5 times (MAWP)</p> <p><u>not</u> marked with “MANUAL SHUT-OFF VALVE”</p> <p><u>not</u> clearly marked with working pressure</p>

Note: All inspection procedures are visual unless additional inspection procedures are indicated. Conditions shown *in this manner* are defined conditions. The definitions can be found in the introduction section.

ITEM AND METHOD OF INSPECTION:	REJECT IF:
<p>j) automatic shut-off valve</p> <p><i>Note:</i> Decals and stencils are acceptable means of marking.</p>	<p>j) <u>not</u> installed in the outlet of the manifold</p> <p>does <u>not</u> shut off when the engine is stopped or ignition switch is in the off or at accessory positions</p> <p>low engine oil pressure is <u>not</u> sensed</p> <p>does <u>not</u> shut off when engine vacuum is <u>not</u> present</p> <p><u>not</u> suitable for the maximum allowable pressure of the container</p> <p>leakage occurs at less than 1.5 times (MAWP)</p> <p><u>not</u> marked with "AUTOMATIC SHUT-OFF VALVE"</p> <p><u>not</u> clearly marked with working pressure</p>
<p>k) pressure relief valve</p> <p><i>Note:</i> Any device used for leak testing of a LNG fuel system must have an accuracy of +/- 2% of the MAWP of the system.</p>	<p>k) leaks at pressure below highest relief valve pressure setting</p>
<p>l) automatic fuel supply shut-off valve</p>	<p>l) <u>not</u> adjacent to the manual shut-off valve</p> <p><u>not</u> protected as required</p> <p><u>not</u> activated by the absence of engine rotation or oil pressure</p>
<p>m) pressure gauge</p>	<p>m) is <u>not</u> readily visible by the driver when the engine enclosure is removed or when standing on either side of the vehicle</p> <p>is <u>not</u> located outside driver or passenger compartment</p> <p>is <u>not</u> equipped with a limiting orifice</p> <p>is <u>not</u> equipped with a shatter-proof dial lens</p> <p>is <u>not</u> equipped with a body relief</p>
<p>n) pressure regulator</p>	<p>n) <u>not</u> securely mounted</p> <p><u>not</u> protected as required to prevent malfunction from low ambient air temperatures (- 40 degrees)</p>
<p>o) supply line</p> <p><i>Note:</i> A damaged line <u>must</u> be replaced.</p>	<p>o) sagging or <u>not</u> supported at least every 610 mm</p> <p><i>damaged</i> or repaired</p>
<p>p) pipe, tubing, hose and fitting</p> <p><i>Note:</i> All materials and assemblies must be designed for the widest pressure and temperature ranges to which they may be subjected with a pressure safety factor of at least four.</p>	<p>p) aluminum or copper is used between the container and first-stage regulator</p> <p>pressure safety factor of material is <u>not</u> at least four</p>

Note: All inspection procedures are visual unless additional inspection procedures are indicated. Conditions shown ***in this manner*** are defined conditions. The definitions can be found in the introduction section.

ITEM AND METHOD OF INSPECTION:	REJECT IF:
q) piping installation	q) installed <u>without</u> adequate allowance for vibration installed <u>without</u> adequate protection against damage or breakage due to strain or wear
r) pipe thread sealant <i>Note:</i> Suitable thread sealant is required on all male pipe threads prior to assembly upon initial installation and for component repair or replacement.	r) sealant used is <u>not</u> impervious to the action of fuel sealant is <u>not</u> applied to male pipe threads prior to assembly
s) pipe and thread condition	s) threading burrs or scaling are present pipe or fitting ends are <u>not</u> reamed
t) gaseous fuel cut-off for dual fuel system <i>Note:</i> Used in applications where a small amount of diesel fuel is injected into the cylinder of the engine during pre 'ignition'.	t) no means is provided to prevent the flow of gaseous fuel to the carburetor or injector fuel rail when diesel fuel is used in pre 'ignition' when ignition switch is in the off or accessory position, or from the carburetor when engine vacuum is <u>not</u> present
u) bypass relief device <i>Note:</i> A standalone bypass relief device is required when a vehicle is not equipped with a fuel pump containing a bypass relief device by the <i>OEM</i> or <i>manufacturer</i> .	u) does <u>not</u> function in accordance with <i>OEM</i> design is <u>not</u> located between the fuel pump and automatic shut off valve in the liquid fuel line to carburetor is <u>not</u> located between the fuel pump and automatic shut off valve in injector fuel rail on a vehicle with dual fuel system
v) vehicle fuelling connection	v) does <u>not</u> have an approved fuelling connection for each pressure-based fuel system is <u>not</u> protected from moving parts, lift-able cab enclosure, engine cover, hinge or direct side impact
w) fuel-carrying component (excluding service valves, tubing and fittings)	w) is not labeled or stamped to show all of the following: <ul style="list-style-type: none"> • <i>manufacturer's</i> name or symbol • model designation • maximum allowable working pressure • design temperature range • direction of flow of fuel • capacity or electrical rating as applicable • scheduled replacement date if applicable
x) road clearance	x) lowest part of any component in the system, including protective guards, is below the lowest edge of the wheel rim
y) fuel system protection	y) any system component is not protected from: <ul style="list-style-type: none"> • any moving part in engine compartment • lift-able cab enclosure • engine cover, hinge or support device • direct side impact

Note: All inspection procedures are visual unless additional inspection procedures are indicated. Conditions shown ***in this manner*** are defined conditions. The definitions can be found in the introduction section.