

---

# **School Planning Manual**

---

**2023**

---

**Department of  
Transportation and Infrastructure**

**Building Design and Construction**

**Government of  
Newfoundland and Labrador**

---



## TABLE OF CONTENTS

<b>PREFACE</b> .....	<b>iv</b>
Intent .....	iv
Precedents .....	v
Nomenclature .....	vii
Definitions.....	viii
Organization .....	ix
<b>1.0 GENERAL REQUIREMENTS</b> .....	<b>1</b>
<b>2.0 FACILITY SPACE PROGRAM</b> .....	<b>5</b>
<b>3.0 SITE INFRASTRUCTURE</b> .....	<b>54</b>
<b>4.0 BUILDING ENVELOPE</b> .....	<b>59</b>
<b>5.0 FIT-UP AND FINISHES</b> .....	<b>64</b>
<b>6.0 FOOD SERVICES</b> .....	<b>70</b>
<b>7.0 CONVEYING SYSTEMS</b> .....	<b>71</b>
<b>8.0 MECHANICAL / SPRINKLERS</b> .....	<b>73</b>
<b>9.0 ELECTRICAL DISTRIBUTION</b> .....	<b>75</b>
<b>10.0 ELECTRICAL LIGHTING</b> .....	<b>84</b>
<b>11.0 ELECTRICAL EMERGENCY POWER</b> .....	<b>86</b>
<b>12.0 COMMUNICATIONS, DATA AND SECURITY</b> .....	<b>87</b>
<b>13.0 LEED</b> .....	<b>94</b>
<b>14.0 COMMISSIONING</b> .....	<b>95</b>
<b>15.0 FURNITURE &amp; EQUIPMENT</b> .....	<b>97</b>
<b>16.0 APPENDICES</b> .....	<b>98</b>

**LIST OF APPENDICES:**

**Appendix A – Standard Layouts and Details**

**Appendix B – Site Selection Criteria**

**Appendix C – Sound Transmission Ratings**

**Appendix D – School HVAC Design Guide 2023**

**Appendix E – Bike Rack Details**

**Appendix F – FIBA Basket Ball Court**

**Appendix G – Soccer Net Anchoring Guidelines**

**Appendix H – School Network Infrastructure Requirements 2023**

**Appendix I – Card Access Control System**

**Appendix J – Closed Caption Television System**

**Appendix K – Standard School Spatial Programs**



## **PREFACE**

### **Intent**

This document serves as a guideline for the design of schools in the Province of Newfoundland and Labrador. It is supplementary to all existing codes and regulations that govern the design of buildings in the province and does not supersede those in the case of conflict between proscriptions contained therein. In the event of a conflict between Universal Design Standard 2021 (UDS 2021) published by the Department of Transportation and Infrastructure and NLBAA/NLBAR, CAN/CSA B651-12 or any other applicable act or regulation, the more stringent shall be applied.

Notwithstanding, these guidelines describe minimum requirements for the satisfaction of the standards of the Department of Transportation and Infrastructure of the Government of Newfoundland and Labrador with regard to the design and construction of schools in the province. They describe parameters that apply to all new construction for NL Schools including new schools and extensions to existing schools.

The Department of Transportation and Infrastructure is issuing these standards for the development of designs for schools in Newfoundland and Labrador in conjunction with the Project Management and Design Administration (PMDA) document and the NL Master Specification Guide for Public Funded Buildings published by the Department of Transportation and Infrastructure.

## Precedents

Current editions of the following precede the standards set forth in this document and are complementary to them:

ANSI S12.60-2002 Acoustical Performance Criteria, Design Requirements and Guidelines for Schools

CAN/CSA B651-12 Accessible Design for the Built Environment

CAN/CSA-T527 Grounding and Bonding for Telecommunications in Commercial Buildings

CAN/CSA-T529, T530 and T531 Design Guidelines for Telecommunications

CAN/CSA-Z462 Workplace Electrical Safety Standard

CAN/ULC-S524 Installation of Fire Alarm Systems

CAN/ULC-S536 Inspection and Testing of Fire Alarm Systems

CAN/ULC-S537 Verification of Fire Alarm Systems

Canadian Electrical Code, Part I (CEC)

IESNA – Illumination Engineering Society of North America

Leadership in Energy and Environmental Design (LEED)

Newfoundland and Labrador Building Accessibility Act (NLBAA)

Newfoundland and Labrador Building Accessibility Regulations (NLBAR)

Newfoundland and Labrador Build Better Buildings Policy (BBB), Government of Newfoundland and Labrador

NL Master Specification Guide for Public Funded Buildings, Department of Transportation and Infrastructure, Government of Newfoundland and Labrador

National Building Code of Canada (NBCC)

National Fire Code (NFC)

National Fire Protection Association (NFPA 101)

National Energy Code for Buildings (NECB 2020)

Safe and Caring Schools Policy (Revised 2013), Department of Education, Government of Newfoundland and Labrador

Universal Design Standard 2021 (UDS 2021), Department of Transportation and Infrastructure, Building Design and Construction Division

## Nomenclature

For the purpose of this document the following nomenclature and abbreviations are used:

'the Department'- the Department of Transportation and Infrastructure, Government of Newfoundland and Labrador (DTI)

BBB – Build Better Buildings Policy, Government of Newfoundland and Labrador

CEC – Canadian Electrical Code, Part 1

EEMAC - Electrical Equipment Manufacturers Association of Canada

NBCC – National Building Code of Canada

NLBAA/NLBAR – Newfoundland and Labrador Building Accessibility Act and Newfoundland and Labrador Building Accessibility Regulations

NL Master Specification Guide for Public Funded Buildings – Department of Transportation and Infrastructure, Government of Newfoundland and Labrador

UDS 2021 – Universal Design Standard 2021, Department of Transportation and Infrastructure, Government of Newfoundland and Labrador

## Definitions

“acoustically isolate” – means in the floor plan layout, place the described space at a physical distance from spaces that are designated for activities that generate excessive noise (e.g. Music Room, Gymnasium, Home Economics Room, Applied Technology and Skilled Trades Laboratories).

“acoustically insulate” – means provide building assemblies between the described space and other spaces that contain acoustic insulation, are designed for acoustic dampening of transferred sound and have a Sound Transmission Rating: Sound Transmission Class (STC) design requirement (Refer to: Appendix C – Sound Transmission Ratings).

“acoustically seal” – means provide openings (doors, viewing windows etc.) between the described space and adjacent spaces with acoustic seals. Implicit here is also the requirement that all wall assemblies that surround the described space are acoustically insulated in order to maintain the design Sound Transmission Rating: Sound Transmission Class (STC).

“accessibility” – means design in compliance with the Department of Transportation and Infrastructure Universal Design Standard 2021 (UDS 2021) and the Newfoundland and Labrador Building Accessibility Act and Regulations (NLBAA/NLBAR).

## **Organization**

The listing of spaces under Section 2.0 – Facility Space Program of this document is organized alphabetically to facilitate direct design reference for specific spaces and does not imply spatial proximity or organizational priority. It is consistent with the allocation of spaces in the Facility Space Programs developed for each new school by the Department of Transportation and Infrastructure. Not all spaces in the Facility Space Program warrant extensive supplemental requirements in this document.

All documents referred to specifically in this document and not otherwise available elsewhere are included in Appendices.

## **1.0 GENERAL REQUIREMENTS**

The following general requirements apply to new school construction and to new construction that is part of a renovation or extension of an existing school.

### **1.1 Accessibility**

- 1.1.1 Design schools to be accessible throughout in accordance with Universal Design Standard 2021 (UDS 2021), Department of Transportation and Infrastructure, Government of Newfoundland and Labrador.
- 1.1.2 In the event of a conflict between UDS 2021, NLBAA/NLBAR, CAN/CSA B651-12 or any other applicable act or regulation, the more stringent shall be applied.
- 1.1.3 Provide tactile direction indicators from main entrance to major points of interest: Administration Office, Library, Gymnasium, elevators, stairways etc.
- 1.1.4 Make all entrances/exits accessible.

### **1.2 Egress**

- 1.2.1 Ensure that egress from all instructional spaces is located at the 'front' of the room opposite the location of the instructor's desk. Provide egress windows only in non-sprinklered schools as required by code (NBCC/NFPA 101/NFC).
- 1.2.2 Provide fire egress plans (digital/Autocad) for each space.

### **1.3 Structural Commissioning**

- 1.3.1 Design and commission all supports, connections and mounting conditions for all equipment to ensure that structural sign-off is attained from the structural engineer of record.
- 1.3.2 Ensure that all elements attached to the walls and ceilings are installed according to manufacturer's instructions and

are attached to building structure by a safety chain or cable in addition to the primary mechanical fasteners. Ensure that all light fixtures, diffusers, basketball nets, acoustic panels, etc. are installed with this secondary mechanical attachment.

- 1.3.3 Provide secondary mechanical fastening to above-ceiling structure for all light fixtures including in the main entrance vestibule and Lobby and all secondary vestibules. Ensure that all lighting diffuser grilles are connected to the lighting fixture by a safety chain or cable as well as by the primary mechanical fasteners. Ensure that lighting fixtures in T-bar ceiling grids are secured with fastening clips.

#### **1.4 Safe and Caring School**

- 1.4.1 The Department of Education's Safe and Caring Schools policy is to be incorporated into the design. Refer to: the Safe and Caring Schools Policy of the Department of Education, Government of Newfoundland and Labrador at: <https://www.gov.nl.ca/education/k12/safeandcaring/>

- 1.4.2 Provide a Lockdown Alarm incorporating amber coloured emergency strobe lights in the following locations:

All Corridors  
All Washrooms  
Gymnasium  
Music Room  
Main Entrance Lobby  
School Exterior near the Main Entrance and Playground.

Provide a manual switch, identified by high contrast sign, in the Administration Office for the activation of the Lockdown Alarm. Activation of the Lockdown Alarm system must automatically disable the card access system for door control.

- 1.4.3 Confirm and co-ordinate with the Department with regard to the number and location of video display monitors to be provided in the Corridors, Lobby, Lunch/Multipurpose Room and Staff/Teacher Preparation Room.



## **1.5 Approvals and Permits**

1.5.1 Confirm and co-ordinate with the Department with regard to the requirements and procedures for attaining relevant permits from the authority having jurisdiction.

1.5.2 Ensure that “Application for Building Accessibility Design Registration or Exemption” forms are completed and forwarded to Service NL and/or the municipality as required, along with two copies of the contract documents prior to tender call; form available here:

<https://www.gov.nl.ca/dgsnl/files/licenses-building-appl-building-registration.pdf>

1.5.3 Ensure that the responsibility for construction permits and other approvals is clearly assigned.

1.5.4 If during construction the temporary closure of an existing exit is required, ensure that the closure is coordinated with the Department and prepare an alternate egress plan in consultation with the School District and attain approval from the NLFSL Office of Fire Commissioner (in conjunction with the St. John's Regional Fire Department for schools in the St. John's Region for inspection and verification) prior to the closure. Ensure that all alternate means of egress are available and operable during construction.

## **1.6 Signage**

1.6.1 Include the school name and other signage in the construction contract. Confirm the name, location, font, size, colour and mounting procedures with the Department prior to tender.

1.6.2 Provide braille and photo luminescent signage throughout the school.

## **1.7 Appendices**

1.7.1 Appendices A - J have been provided to supplement the requirements outlined in this document and must be refined

in consultation with the Department and applied to all spaces as applicable.

- 1.7.2 In the event that the School Planning Manual text contradicts elements of the Appendices, the SPM text supersedes that shown in the appendices with the exception of Code and Standards mandated items.

## **2.0 FACILITY SPACE PROGRAM**

### **2.1** The following spaces are defined as Instructional Spaces:

Art Room  
Kindergarten  
Primary (Grades 1-3)  
Elementary (Grades 4-6)  
Intermediate (Grades 7-9)  
High School (Grades 10-12/Level I-III)  
Art Room  
Computer Lab: CDLI  
Computer Lab: ICLT  
Home Economics  
Instructional Resource Room (IRR)  
Instructional Resource Suite (IRS)  
Music/Band Room  
Science Laboratories  
Chemistry/Biology Laboratories  
Physics Laboratories  
Theatre/Drama  
Applied Tech Lab (Grades 7-9) - Fabrication Room  
Applied Tech Lab (Grades 7-9) - Planning/Design Room  
Skilled Trades Lab (Grades Level I-III) - Fabrication Room  
Skilled Trades Lab (Grades Level I-III) - Planning/Design Room

### **2.2 Administration Office**

The Administration Office Suite comprises: Principal's Office, Assistant Principal's Office, Medical/Sick Room with adjacent washroom, reception desk, waiting area, clerical support area, clerical support storage and a server/digital records storage room.

2.2.1 Locate the Administration Office on the ground floor adjacent to the main entrance and with viewing window(s) to the Lobby, main entrance and vestibule. Provide glazed protrusions in the Administration Office extending min. 600mm into the adjacent corridors to facilitate corridor surveillance. Similarly, provide glazed protrusions extending min. 600mm from the exterior face of the building to facilitate surveillance of the main entrance and exterior of the school.

- 2.2.2 Provide a lockable operable pass-through window in the Administration Office that opens into the main entrance vestibule to allow for item drop-off without entrance into the school.
- 2.2.3 Provide a copy room adjacent to the clerical support area and reception desk. Confirm and co-ordinate with the Department with regard to size of the clerical support/copy room required.
- 2.2.4 Provide a storage area adjacent to the clerical support area.
- 2.2.5 Locate the Principal's and Assistant Principal's Offices behind the reception desk with direct access to the clerical support area and on an exterior wall with views of the school grounds in front of the main entrance.
- 2.2.6 Provide a waiting area in the Administration Office near the reception desk large enough to accommodate no less than five (5) chairs.
- 2.2.7 Provide a Medical/Sick Room in the Administration Suite with lockable cabinets and with direct access from the clerical support area. Provide an accessible washroom in the Administration Office adjacent to and with direct access to the Medical/Sick Room. Provide a Nurse Call system in the Medical/Sick Room and Medical/Sick Room washroom in the Administration Office.
- 2.2.8 Provide a server/digital records room adjacent to the Administration Office clerical support area. Provide the server/digital record rooms with adequate ventilation and air conditioning (Refer to: Appendix D – HVAC Design Guide and Appendix H – Network Infrastructure Requirements).
- 2.2.9 Provide wall-mounted shelving above the server in the server/digital storage room to hold digital and print records consisting of not less than 4000mm of linear storage in 4 shelves at 350mm deep. Ensure that all equipment in the server/digital records room, except for computers, is included in the construction contract.
- 2.2.10 Provide controls/monitoring for intercom system/public address system and CCTV system in Administration Office.

- 2.2.11 Provide a desk that separates the waiting area from the administration staff area having a minimum horizontal length of 4m at standing counter height and minimum horizontal length of 4m at desk height designed in accordance with Universal Design Standard 2021 (UDS 2021).
- 2.2.12 Provide a manual activation switch for the lockdown alert amber coloured strobe emergency light identified by an engraved nameplate in high-contrast colours.

## **2.3 Art Room (Visual Art)**

- 2.3.1 In floor plan layout, acoustically isolate the Art Room from areas that generate excessive noise such as the Music Room, the Gymnasium, the Home Economics Room and the Fabrication Room of the Applied Technology/Skilled Trades laboratories.
- 2.3.2 Provide not less than one (1) accessible stainless steel double clean-up sink (914mm wide x 432mm deep) with a wall-mounted faucet with a swivel gooseneck spout, lever handles, aerated nozzle, stainless steel basket strainer, and chrome-plated off-set traps. Cover any exposed plumbing below the counters with vandal proof, slanted, vinyl covered panels to conceal plumbing below all vanities and counters; ensure that a service panel can be removed to allow maintenance.
- 2.3.3 Provide not less than one (1) accessible work station in the Art Room.
- 2.3.4 In high schools identified as requiring a kiln, provide a separate room for the kiln with a 60A, 240v feed and 4" metal exhaust access (as per manufacturer's instructions and all applicable codes). Electrical to be capped in covered electrical box (i.e. no specific outlet required) and duct capped/sealed for future access/use. Kiln will be supplied and installed by others unless noted otherwise.
- 2.3.5 Design for 'wet media' and 'dry media' zones within the Art Room. Provide access to sinks, tools, and materials in 'wet media' zone; computers, monitors and other technological equipment in 'dry media' zone. Provide storage for both 'wet media' and 'dry media' materials, equipment including light tables, easels, and stools. Storage cabinet millwork is not acceptable above sinks in the wet storage area of the Art Room. Ensure that there are no operable cabinets or open shelves for storage above sinks in the millwork; provide only a millwork cover with a light valence above sinks. Refer to: Appendix A – Standard Layouts and Details for millwork requirements.
- 2.3.6 Provide a sealed floor with drainage and non-slip synthetic floor covering in 'wet media' zone.

- 2.3.7 Provide display space for art inside and outside the Art Room (flat wall space with a hinged Plexiglas shield in the corridor). Provide secure cabinetry to display 3-D work in the Art Room.
- 2.3.8 Provide millwork with drawers to accommodate paper sizes from A4 (210mm x 297mm) to A0 format (1189mm x 841mm). Refer to: Appendix A – Standard Layouts and Details for millwork requirements.
- 2.3.9 Provide neutral wall colors (e.g. white, off-white, and beige) in the Art Room.
- 2.3.10 Design for windows that face north to provide consistent natural light with low contrast and minimum shadows and glare.

## **2.4 Classrooms: Kindergarten**

- 2.4.1 Locate Kindergarten (K) classrooms on the ground floor near the main entrance and with access to the Kindergarten (K) and Primary (1-3) playground and clustered together in floor plan layout so as to minimize interaction with older students.
- 2.4.2 Provide radiant heating ceiling panels in all Kindergarten (K) classrooms above an area 3048mm wide and 2440mm deep with the long side parallel to and offset 2000mm from the front wall of the classroom and centered on the Interactive Television (ITV); Refer to: Appendix A – Standard Layouts.
- 2.4.3 All Kindergarten classrooms shall include millwork including cabinets, sink, coat hooks, individual storage shelving for personal items, and a boot rack.
- 2.4.4 Counter heights shall be in accordance with the minimum height permitted in the Universal Design Standard 2021. Counters to be installed at lowest height permitted by standard.
- 2.4.5 Provide a accessible washroom with standard sized fixtures; provide a manual operation flush toilet.



## **2.5 Classrooms: Primary (Grades 1-3)**

- 2.5.1 Locate Primary Classrooms on the ground floor and clustered together in floor plan layout so as to minimize interaction with older students.
- 2.5.2 Provide radiant heating ceiling panels in all Primary classrooms: 3048mm wide and 2440mm deep with the long side parallel to and offset 2000mm from the front wall of the classroom and centered on the Interactive Television (ITV).

## **2.6 Classrooms: Elementary (Grades 4-6)**

- 2.6.1 Locate Elementary (4-6) Classrooms together in floor plan layout so as to minimize interaction with older students.

## **2.7 Classrooms: Intermediate (Grades 7-9)**

- 2.7.1 Ensure that Intermediate Classrooms are clustered together in floor plan layout so as to minimize interaction with younger students and are separated from Kindergarten, Primary, and Elementary students either by building wing or floor level.

## **2.8 Classrooms: High School (Levels I - III)**

- 2.8.1 Ensure that High School Classrooms are clustered together in floor plan layout so as to minimize interaction with younger students and are separated from Kindergarten, Primary, and Elementary students either by building wing or floor level.

**2.9 Computer Laboratory: Center for Distance Learning and Innovation (CDLI/e-Learning)**

- 2.9.1 Provide a dedicated CDLI/e-Learning Computer Laboratory for High School (Level I-III) grade levels in rural areas.
- 2.9.2 Locate CDLI/e-Learning Computer Laboratory adjacent to a well-supervised space such as the Learning Resource Center (LRC) or the Administration Office and ensure a visual connection is provided through viewing windows between the adjacent spaces. Provide laminated safety glazing in all viewing windows.
- 2.9.3 Ensure that adequate electrical and mechanical services are provided for all equipment.
- 2.9.4 Provide a dedicated air conditioning system adequate to accommodate all computer equipment in the CDLI/e-Learning Computer Laboratory (Refer to: Appendix D – HVAC Design Guide).
- 2.9.5 Ensure flexibility in space utilization through the use of mobile workstations and wireless capabilities. (Refer to: Appendix H – Network Infrastructure Requirement).

**2.10 Computer Laboratory: Information Communications and Learning Technologies (ICLT)**

- 2.10.1 Locate the ICLT Computer Laboratory near the Learning Resource Centre (LRC) with primary access directly from the LRC. In small schools, without a dedicated Applied Technology/Skilled Trades Planning Room, locate the ICLT Computer Laboratory adjacent to the Fabrication Room so that it can be used for computer-based design and planning.
- 2.10.2 Ensure that adequate electrical and mechanical services are provided for all equipment.
- 2.10.3 Provide a dedicated air conditioning system adequate to accommodate all computer equipment in the ICLT Computer Laboratory (Refer to: Appendix D – HVAC Design Guide).

## **2.11 Corridors**

- 2.11.1 Provide straight corridors with no alcoves or hidden spaces. Ensure that all doors swing out into the corridor.
- 2.11.2 Confirm and co-ordinate with the Department with regard to the number, location and configuration of lockers required. Provide an adequate number of ventilated lockers along the school corridors to accommodate the school population in accordance with Section 5.9 (Refer to: Appendix A - Standard Layouts and Details, Appendix D – HVAC Design Guide and the Safe and Caring Schools Policy).
- 2.11.3 Provide an amber coloured strobe emergency light in all Corridors for activation during lockdown scenarios.

## **2.12 Family Resource Centre (FRC)**

- 2.12.1 Confirm and co-ordinate with the Department with regard to the provision of a Family Resource Centre (FRC).
- 2.12.2 Locate Family Resource Center close to the main entrance for public access; if not possible, provide card access control for FRC entrance.
- 2.12.3 Provide an accessible washroom with standard sized fixtures including manual operation flush toilets within FRC.
- 2.12.4 Confirm and co-ordinate with the Department with regard to the extent and type of millwork provided in the FRC.

## 2.13 Fitness Centre

- 2.13.1 In floor plan layout locate the Fitness Centre adjacent to the Gymnasium with direct access to and visual connection to the Gymnasium through a viewing window.
- 2.13.2 Provide a ceiling height of not less than 3000mm.
- 2.13.3 Provide 1220mm tall viewing windows of laminated safety glazing for supervision from the Gymnasium. Ensure that viewing windows span the full width of the Fitness Centre with a sill at not less than 915mm above finish floor level. Ensure that the viewing window is installed such that the minimum window frame depth faces the Gymnasium side so as to not interfere with play. Provide a Fitness Room door with a top glazing unit only.
- 2.13.4 Provide double doors with a removable mullion for the movement of equipment at the entrance to the Fitness Centre.
- 2.14.1 Provide standard Gymnasium sport flooring without welded seams or seamless poured rubber (Pulastic®) flooring in the Fitness Centre.
- 2.13.5 Confirm and co-ordinate with the Department with regard to the number and types of equipment required. Provide adequate electrical power and data for all equipment (Refer to: Appendix H – Network Infrastructure Requirements).
- 2.13.6 Provide a dedicated air conditioning system adequate for the capacity and use anticipated (Refer to: Appendix D – HVAC Design Guide).
- 2.13.7 Provide an Interactive Television (ITV) installed such that it is visible from all exercise stations/equipment.
- 2.13.8 Provide adequate electrical and mechanical services for all equipment.

## **2.14 Guidance/Itinerant Teacher Suite**

- 2.13.1 Locate a Guidance Suite on the ground floor and in the vicinity of the Administration Office comprising: one office large enough to accommodate a desk, a table, a bookcase and not less than two (2) chairs, two small offices large enough to accommodate a desk and not less than two (2) chairs, a waiting area directly outside the offices large enough to accommodate a computer desk and not less than one chair per office. Ensure that the Guidance Suite has direct access to the corridor.
  
- 2.13.2 Ensure that the Guidance Suite is acoustically isolated and acoustically insulated from adjacent spaces. Acoustically seal all doorways in the Guidance Suite and that leading from the Guidance Suite to the corridor. Acoustically insulate offices from one another and from the waiting area including means to acoustically insulate above-ceiling spaces. Provide offices with lockable (from outside only) insulated metal or solid core doors with acoustic door seals on all sides including thresholds (see Appendix C – Sound Transmission Ratings).

## 2.14 Gymnasium

- 2.14.2 Confirm and Co-ordinate with the Department with regard to the Gymnasium size and specific Gymnasium court line layouts in accordance with school population and age/grade range ensuring that all court lines are visible and are clear where layouts align and overlap (using split lines). (Refer to: Appendix A- Standard Layouts and Details and Appendix G – FIBA2015 Basketball Court).
- 2.14.3 In floor plan layout, acoustically isolate the Gymnasium from other instructional spaces including the Music Room.
- 2.14.4 Locate the Gymnasium at grade level with easy public access and with access to the main entrance Lobby. Ensure that the Gymnasium and Lobby can be secured to allow public access during after-hours use without access to the remainder of the school.
- 2.14.5 Ensure that the unobstructed clearance above playing surface is not less than 6000mm for schools with Kindergarten (K) - Primary (1-3) and Elementary Grades (4-6) and not less than 7380mm for schools with Intermediate (7-9) and High School (L I-III) grades.
- 2.14.6 Ensure that there are no projections from Gymnasium walls such as columns and furring. Ensure that all electrical equipment and lights are mounted at not less than 4000mm above the playing surface. Provide low profile protective guards or cages for all electrical equipment in the Gymnasium. Ensure that all electrical conduit in the Gymnasium is concealed in walls. Ensure that all lights switches, fire pull stations, fire extinguisher cabinets etc. that are less than 4000mm above the playing surface are flush-mounted.
- 2.14.7 Ensure that wall clocks in the Gymnasium are mounted on end walls and provided with protective cages that enclose all sides including a slanted portion on top.
- 2.14.8 Provide one (1) electronic scoreboard in Kindergarten/Primary/Elementary (K-6) School Gymsnasiums; ensure that it is centrally located so that it is visible from both ends of the Gymnasium.

- 2.14.9 Provide two (2) electronic scoreboards in larger Gymnasiums for Intermediate (7-9) and High School (Level I-III) grades where tournament play is an expected use. Locate each so that they are visible from both ends of play areas created by the divider curtain.
- 2.14.10 Ensure that all exterior windows in the Gymnasium are placed at not less than 4000mm from the floor. Provide internal sun screening or glazing designed for the reduction of glare in exterior windows.
- 2.14.11 Specify standard synthetic Gymnasium flooring without welded seams or seamless poured rubber (e.g. Pulastic®) flooring in schools with Kindergarten (K) – Primary (1-3) and Elementary Grades (4-6).
- 2.14.12 Provide flooring without welded seams or seamless poured rubber (e.g. Pulastic®) flooring in the Gymnasium.
- 2.14.13 Specify hardwood gymnasium flooring in schools with Intermediate (7-9) and High School (Level I-III) grades. Ensure that the HVAC system is designed and maintained year round to prevent warping of the hardwood Gymnasium flooring. Mount additional temperature and humidity sensors at floor level as needed (Refer to: Appendix D – HVAC Design Guide).
- 2.14.14 Ensure that the ground and concrete slab-on-grade moisture content is in the acceptable range for the installation of the Gymnasium flooring as per manufacturer's specifications. Employ a vapor retarder of not less than 10mil thickness under the concrete floor slab-on-grade.
- 2.14.15 Provide retractable basketball nets controlled by an electric winch and with vertical adjustment on all main and side courts; install control switch on Gymnasium wall with clear view of retractable net operation. Provide basketball nets with acrylic or glass backstops on the main court only. Ensure that side court basketball nets in the retracted position do not interfere with play on main court.
- 2.14.16 Ensure that the basketball nets in Primary (1-3) and Elementary (4-6) School grades are adjustable to heights between 2438mm and 3048mm.



2.14.17 Ensure that the location of floor sockets for volleyball posts are clearly specified at 1m beyond court side lines.

2.14.18 Provide safety pads specifically designed for the volleyball posts supplied.

2.14.19 Specify acoustic concrete masonry units or acoustically absorbent panels for acoustical treatment on the walls of the Gymnasium at a height not less than 4000mm above the playing surface.

2.14.20 Specify acoustic block as follows:

- **Acoustical concrete block units:**  
to CAN3-A165 Series (CAN3A165.1), purpose made with skewed and sloped surfaces edged by (2) 90 degree linear profiles to provide the acoustical characteristics specified; complete with noise attenuating fillers meeting UK94HF-1.
- **Classification:**  
H/10/C/M.
- **Size:**  
Modular.
- **Acoustical characteristics:**  
Decorative design as specified and/or detailed.
- **Sound diffusion:**  
Irregular surfaces to “spray” the reflected sound energy.
- **Flutter echo:**  
Not less than of 75% skewed and sloped surfaces at not less than 0.3 to 1 ratio for non-parallel surfaces.
- **Standing wave/resonate frequencies:**  
absorption coefficient 1.2 at 1.25 Hz.
- **Absorption/Helmholtz Resonator:**  
Not less than of 90% at 100, 125 and 160Hz frequency bandwidths.

2.14.21 Confirm and co-ordinate with the Department with regard to the requirement for a Gymnasium divider and the type and size needed. Ensure that the minimum clearance

above the Gymnasium floor is maintained when divider is in the fully-raised position. Install control switch on Gymnasium wall with clear view of Gymnasium divider operation. Divider curtain must be mechanically fastened to the retractor drum and must have a visible marker to indicate maximum limit of operation. Ensure that limit switches are protected from damage. Ensure structural sign-off is acquired during commissioning for Gymnasium Divider.

- 2.14.22 Provide LED lighting in the Gymnasium; provide LED lighting fixtures that are designed for use in Gymnasiums that do not require protective guards (See Section 1.3 – Structural Commissioning).
- 2.14.23 Provide low profile, high velocity de-stratification fans in Gymnasiums. Install low profile protective cages for de-stratification fans at the Gymnasium ceiling such that the fans are fully enclosed and the cages are either sloped above the fan or are continuous to the underside of the roof deck so as not to interfere with play or sporting equipment (See Section 1.3 – Structural Commissioning).
- 2.14.24 Design all mechanical and electrical services to provide a clean and uncluttered visual appearance in the Gymnasium. Use flat, light-colored paint for exposed roof deck and all mechanical and electrical equipment at the Gymnasium ceiling.
- 2.14.25 Provide an ASSISTED listening device sound system (microphone, amplification, transmitter-receiver, personal-use headsets and speakers) in the Gymnasium and all large assembly spaces in accordance with NBCC.
- 2.14.26 Provide at least one exit directly to the outside from the Gymnasium. Ensure that the exit to the exterior has a double door with a removable mullion for the movement of equipment.
- 2.14.27 Ensure that all exits from the Gymnasium are provided with an accessible landing and ramp on the exterior.

## **2.15 Gymnasium Change Rooms**

- 2.15.1 In floor plan layout, locate separate male and female Change Rooms with direct access to the Gymnasium from each Change Room.
- 2.15.2 Provide at least one (1) private, accessible shower with an adjustable seat height and/or detachable showerhead in both the male and female Change Rooms.
- 2.15.3 Provide a dedicated, semi-private change/drying area in combination with the private, accessible shower.
- 2.15.4 Provide urinals in male Change Room.
- 2.15.5 Provide half height sized ventilated lockers in Change Rooms.
- 2.15.6 Provide fixed benches in the Gymnasium Change Rooms.

## **2.16 Gymnasium Instructor's Office**

- 2.16.1 Provide direct access to and a visual connection with the Gymnasium for supervision from the Gymnasium Instructor's Office through a viewing window.
- 2.16.2 Provide laminated safety glazing in all viewing windows.
- 2.16.3 Provide a viewing window with a sill at not less than 800mm and not more than 900mm above the finish floor level so as to not interfere with supervision by a seated instructor. Ensure that the Gymnasium Instructor's Office door has a top glazing unit only.
- 2.16.4 Ensure that the viewing window is installed such that the minimum window frame depth faces the Gymnasium side so as to not interfere with play.
- 2.16.5 Provide an accessible washroom containing a toilet and sink only (no shower) in the Gymnasium Instructor's Office.

## 2.17 Gymnasium Platform

- 2.17.1 Ensure there is adequate chair storage on the under-platform chair dollies to accommodate the maximum seating capacity for the Gymnasium. Utilize the full depth of the platform by coupling the chair dollies together end to end. Ensure that the platform height above the Gymnasium finished floor and the dolly storage door openings are adequate to accommodate the chair dollies and chair dimensions when fully loaded. Ensure the concrete slab under the platform is level with the Gymnasium finished floor to allow dollies to be pulled out onto the Gymnasium floor without obstruction; provide center track cart guides. Ensure that chair and chair dollies are included in the construction contract.
- 2.17.2 Design the sprinkler head layout, location and clearances underneath the platform such that there is no conflict between the dollies and sprinkler heads so that no sprinkler heads may be damaged by the operation of the fully loaded chair dollies. Ensure that all sprinkler heads are provided with protective cages.
- 2.17.3 Provide floor drains in chair dolly storage area sufficient to accommodate the amount of water expelled from a damaged sprinkler head; provide not less than one (1) floor drain per dolly bay. Slope concrete floor in chair dolly storage area to drain locations.
- 2.17.4 Design and commission all platform lighting, lighting bars, curtains, hoisting equipment and supports to ensure that structural sign-off is attained from the structural engineer of record. Ensure that the platform curtain and support structure is designed to account for student activities (including performance, climbing, pulling etc.) that may place structural demand upon it beyond that of normal operation and curtain weight.
- 2.17.5 Provide a folding partition at the platform proscenium with a Sound Transmission Rating (STC) of not less than 60 (Refer to: Appendix C – Sound Transmission Ratings).
- 2.17.6 Provide proscenium curtain, valance, backdrop curtain, and masking curtains for left and right sides of platform.

Confirm and design for the restrictions on the amount of drapery permitted on the platform.

- 2.17.7 Provide curtains that are inherently flame retardant (i.e. not treated with a spray-on flame retardant after manufacture); provide manufacturer's certification.
- 2.17.8 A sprinkler deluge system is NOT required.
- 2.17.9 Acoustically insulate the underside of stairs leading from Gymnasium floor to the platform if they have wood or metal treads.
- 2.17.10 Design all mechanical and electrical services to provide a clean and uncluttered visual appearance above the platform. Use flat black paint for exposed roof deck and all mechanical and electrical equipment above the Gymnasium Platform including lighting, lighting bars, catwalks, hoisting equipment and supports etc. (see Section 17.0). Use flat black paint for all walls, floors, and ceilings in the backstage of the Gymnasium Platform.
- 2.17.11 Provide a softwood floor for the Platform surface. Ensure that the hardness is sufficient for Platform surface usage.
- 2.17.12 Ensure that the Gymnasium Platform and backstage area is accessible through the use of a ramp from the Gymnasium floor that is compliant with the Universal Design Standard 2021.

## **2.18 Gymnasium Storage Room**

- 2.18.1 Provide direct access to the Gymnasium Storage Room from the Gymnasium.
- 2.18.2 Provide space for wall hooks, adjustable shelves and lockable cupboards (owner supplied).
- 2.18.3 Confirm and co-ordinate with the Department with regard to flooring and wall finishes in the storage room.

## 2.19 Home Economics

- 2.19.1 Locate Home Economics Room at ground level and in floor plan layout, acoustically isolate from other instructional spaces.
- 2.19.2 Provide a ceiling height no less than 3000mm.
- 2.19.3 Ensure that there are two exit doors for egress from the Home Economics Room.
- 2.19.4 Confirm and co-ordinate with the Department with regard to the number and location of all equipment in the Home Economics Room.
- 2.19.5 Include six (6) fully operational food preparation stations.
- 2.19.6 Include one (1) accessible textile instruction table and one (1) accessible food preparation station with a down draft range hood.
- 2.19.7 Provide accessible sinks with shallow depth, fitted with motion sensor activated faucets and chrome-plated off-set traps. Cover any exposed plumbing below the counters with vandal proof, slanted vinyl covered panels to conceal plumbing below all vanities and counters; ensure that a service panel can be removed to allow maintenance.
- 2.19.8 Provide an adjustable (tilting) ceiling-mounted demonstration mirror above the stove at a designated instructor's food preparation station.
- 2.19.9 Provide food preparation stations designed to accommodate five (5) students per station.
- 2.19.10 Ensure that there are no operable cabinets or open shelves for storage above the refrigerators, stoves or sinks in the kitchen millwork. Above stoves, provide only a millwork cover for the exhaust fan ventilation. Above sinks, provide only a millwork cover with a light valence.
- 2.19.11 Provide space for eight (8) rectangular textile instruction tables that can seat four (4) students per table.
- 2.19.12 Provide adequate electrical and mechanical services for all equipment and fixtures. Confirm and co-ordinate with the



Department with regard to the location and the electrical and mechanical requirements for all equipment and fixtures including, but not limited to: hot water supply, task lighting, tamper-proof duplex electrical power receptacles etc.

- 2.19.13 Provide a keyed manual emergency power shut-off switch near the main door into the Home Economics Room. Confirm and co-ordinate with the Department with regard to what equipment is to be connected to the keyed manual emergency shut-off switch including ranges/ovens. Ensure that refrigerators, computers, or any other essential equipment operators are not connected to the emergency power shut-off switch.
- 2.19.14 Provide an electrical cord reel with duplex electrical power receptacles with the capacity to accommodate sewing machines directly over each textile instruction table; ensure that the cord reels are attached to the above-ceiling building structure.
- 2.19.15 Provide adequate electrical and mechanical services for a domestic washer, dryer and laundry tub. Provide cabinets for storage above the washer and dryer. Provide a 15 amp, 120 volt electrical power receptacle for the washer and a 30 amp, 240 volt electrical power receptacle for the dryer to match dryer cord.
- 2.19.16 Provide not less than two (2) tamper-proof duplex electrical power receptacles per food preparation station. Design the layout of electrical power receptacles at the food preparation stations in accordance with the standards for the design of domestic kitchens (Refer to: CEC and NBCC).
- 2.19.17 Provide two (2) refrigerators placed side by side and located on the same wall as the dishwasher. Ensure that dedicated tamper-proof duplex electrical power receptacles are located behind the refrigerators.
- 2.19.18 Ensure that dedicated tamper-proof duplex electrical power receptacles are located behind all microwaves.
- 2.19.19 Provide adequate task lighting at each food preparation station.

- 2.19.20 Provide adequate task lighting at each of the textile instruction tables.
- 2.19.21 Provide space for a instructor's work area including a desk, a chair, a bookshelf, and a filing cabinet with clear sightlines to all areas of the Home Economics Room.
- 2.19.22 Ensure that all windows in the Home Economics Room are positioned above countertop and back splash height and do not interfere with upper cabinets. Ensure that all exterior windows in the Home Economics Room are provided with insect screens.
- 2.19.23 Provide storage cabinets adjacent to the textile instruction area that can accommodate fifteen (15) sewing machines, two (2) sergers, one (1) embroidery machine with a movable workstation cart, large and small pieces of sewing equipment, and textiles. Ensure that storage cabinets consist of stacked drawers and cupboards as follows: pullout drawers with low sides for ergonomic lifting to house sewing machines, drawers for smaller equipment items and upper cabinets for fabric/project storage. Provide a lower unit that houses the portable cart and embroidery machine. Provide a data port paired with a tamper-proof duplex electrical power receptacle within this cabinet. Provide a pantry style cupboard for the storage of ironing boards.
- 2.19.24 Provide a change area adjacent to the textile instruction area with a wall-mounted, full length mirror and a curtain hung from an overhead track. This change area should not be visible from the corridor through the doors to Home Economics Room.

## **2.20 Instructional Resource Room (IRR)**

- 2.20.1 Provide millwork in the Instructional Resource Room (IRR) to match that in Kindergarten (K) and Primary (1-3) grades.

## **2.21 Instructional Resource Suite (IRS)**

- 2.21.1 Provide an Instructional Resource Suite (IRS) comprising a main room, a dedicated washroom directly accessible from the main room, a quiet room, and a vestibule connecting the main room to the school corridor.
- 2.21.2 Provide heavy duty, automatic electronic door operators for accessibility on all doors in the IRS (main room, washroom, and vestibule).
- 2.21.3 Provide a lift in the IRS washroom with a motorized vertical lifting capacity of 800 lbs. and manual horizontal movement along ceiling-mounted track attached to the above-ceiling building structure as indicated in the standard layout. Provide controls and adequate electrical power supply for the operation of the student lift; install power module on wall opposite the bed to allow full range operation of the lift.
- 2.21.4 Provide a motorized change table with controls and adequate electrical power supply for its operation in the IRS washroom.
- 2.21.5 Provide keyed manual emergency power shut-off switch in the IRS main room at an easily accessible location adjacent the main exit door. Ensure that the stove and oven are connected to the emergency power shut-off switch. Do not allow emergency shut-off for refrigerators, computers or any other essential equipment operators. Confirm and co-ordinate with the Department with regard to what equipment is to be connected to the manual emergency shut-off switch.
- 2.21.6 Provide a quiet room in the IRS with vinyl covered wall surfaces and acoustic panels; provide acoustically absorbent panels on not less than 25% of the wall space of the room. Provide a viewing window in the door to the quiet room. Ensure that there is a passage set (no lockset) in the door to the quiet room.

- 2.21.7 Confirm and co-ordinate with the Department with regard to the location, size and configuration of the quiet room and the types of equipment and mechanical and electrical services required (do not install baseboard electric heaters in quiet room).
- 2.21.8 Provide a Nurse Call system in the Instructional Resource Suite and the IRS washroom.

## **2.22 Janitor's Room/Closet**

- 2.22.1 Provide plumbed eyewash stations in janitorial rooms/closets.
- 2.22.2 Provide hot and cold water and an in-floor mop sink.
- 2.22.3 Provide wall mounted faucets (hot and cold), above and in addition to the sink's faucet, for connection to chemical mixing/dispensing unit.

## 2.23 Kitchen

- 2.23.1 Confirm and co-ordinate with the Department with regard to the proposed kitchen layout. Ensure that the proposed kitchen layout is designed by a dedicated kitchen layout designer and is approved by the Department and Service NL (See Appendix A- Standard Layouts and Details).
- 2.23.2 Locate the Kitchen on the ground floor and provide a single door for access from the cafeteria eating area and double doors to outside for deliveries and waste disposal. Design for food delivery, storage and waste disposal in the kitchen layout. Confirm and co-ordinate with the Department with regard to the method for waste storage and disposal.
- 2.23.3 Confirm and co-ordinate with the Department with regard to the kitchen equipment requirements and layout.
- 2.23.4 Ensure that counter heights are coordinated with the height of the under-counter dishwasher.
- 2.23.5 Ensure that there are no operable cabinets or open shelves for storage above the refrigerators, stoves or sinks in the Kitchen. Above stoves, provide only a millwork cover for the exhaust fan ventilation. Above sinks, provide only a millwork cover with a light valence.
- 2.23.6 Provide solid acrylic counter tops throughout the Kitchen.
- 2.23.7 Provide a janitor's closet separate from the food preparation area with a janitor's sink and storage for cleaners.
- 2.23.8 Provide a staff washroom in the Kitchen that has direct access to the preparation area.
- 2.23.9 Provide a stainless steel, three compartment sink for sanitizing utensils.
- 2.23.10 Provide a workstation with a phone, data port and ground fault interrupter (GFI) electrical power receptacle.
- 2.23.11 Provide ½ lockers for the storage of staff personal items.
- 2.23.12 In Intermediate (Grades 7-9) and High School (Level I-III), provide a servery adjacent to the Kitchen that allows

students and staff to pass through in single file using a tray slide system. Display food in see-through refrigeration units that are within reach for all students.

- 2.23.13 Ensure that the Kitchen and server are separated from the adjacent Lunch/Multipurpose Room by a full-height wall that extends to the underside of the floor or roof above. Ensure that all doors including rolling overhead doors can be locked so that the Kitchen and server is secure from entry at all times when not in use.
- 2.23.14 Separate the Kitchen and serving area from Lunch/Multi-Purpose Room by the use of a lockable insulated rolling overhead door for the attenuation of sound from the Kitchen during events held in the Lunch/Multi-Purpose Room (Refer to: Appendix A – Standard Layouts and Details).
- 2.23.15 Confirm and co-ordinate with the Department with regard to the electrical requirements for all kitchen equipment including, but not limited to: hot water supply, task lighting, phone, and data ports/drops.
- 2.23.16 Confirm and co-ordinate with the Department with regard to the number and location of all tamper-proof duplex electrical power receptacles in Kitchen to service all equipment.
- 2.23.17 Provide adequate ventilation and cooling to counteract the heat generated from kitchen equipment.
- 2.23.18 Provide a recycling shed separate and detached from the school. Confirm and co-ordinate with the Department with regard to the location of the recycling shed; provide a shed on a concrete slab-on-grade with electrical power supply for one interior and one exterior light above door and an intrusion alarm. Ensure that the exterior cladding of the recycling shed matches the exterior facade of the school in terms of materials and appearance.

## **2.24 Library/Learning Resource Center (LRC)**

- 2.24.1 Locate the Learning Resource Center (LRC) on the ground floor and near the Administration Office, Lobby and main entrance. In floor plan layout, acoustically isolate from other instructional spaces and away from spaces that generate excessive noise (e.g. Applied Technology/Skilled Trades Laboratory, Music Room, Home Economics Room, and Gymnasium).
- 2.24.2 Confirm and co-ordinate with the Department with regard to exceptional circumstances (schools with small populations) where the LRC can be located adjacent to the Applied Technology/Skilled Trades and ICLT Laboratory so that computers in the LRC may be used by students for multiple purposes.
- 2.24.3 Design LRC such that it has at least one exterior wall with large windows for natural lighting. Provide internal sun screening on all exterior windows for the reduction of glare.
- 2.24.4 Confirm and co-ordinate with the Department with regard to the layout of all furniture and equipment located in the LRC.
- 2.24.5 Provide a circulation desk near the main entrance/exit door commanding a view of the entire LRC. Design the circulation area for the temporary storage of books, carts, and computers and other library equipment. Design the circulation desk to meet accessibility requirements and to accommodate the variety of student ages in the school population.
- 2.24.6 Provide space at the circulation desk to accommodate one (1) station for a computer-based automated catalogue access system for every 250 students, integrated with an automatic electronic alarm system at the entrance/exit door to indicate whether an item has been checked out properly.
- 2.24.7 Design LRC to accommodate book stacks, computer stations, reading areas, and seating for group and individual activities. Provide a separate reading area for Kindergarten/Primary/Elementary (K-6) students in the LRC in any school that includes higher grade levels.

- 2.24.8 Design LRC such that there is free wall space and/or floor space to accommodate display cases and bulletin boards.
- 2.24.9 Provide a storage room for audio visual equipment with direct access to the LRC.
- 2.24.10 Provide a media production room separate but adjacent to and with direct access to the LRC specifically designed for media production and editing, including appropriate lighting, ventilation, temperature, humidity, and acoustic specifications.
- 2.24.11 Provide a dedicated air conditioning system adequate to accommodate all computer equipment in the media production room Refer to: Appendix D – HVAC Design Guide.



## **2.25 Lobby**

- 2.25.1 Include not less than one (1) trophy case in the Lobby adjacent to the main entrance and near the Administration Office and Gymnasium entrance. Confirm and co-ordinate with the Department with regard to the number, size and location of trophy cases required. Ensure that adequate electrical power and lighting is provided in trophy cases.

## 2.26 Lunch Room

- 2.26.1 Confirm and co-ordinate with the Department with regard to the requirement in schools with small populations for the Lunch Room to be used as a Multi-Purpose Room.
- 2.26.2 Locate the Lunch Room on ground floor and provide double doors to outside for egress, delivery and waste disposal.
- 2.26.3 Confirm and co-ordinate with the Department with regard to the location of recycling collection containers and waste disposal containers in the Lunch Room.
- 2.26.4 In floor plan layout, acoustically isolate the Lunch Room from instructional spaces.
- 2.26.5 In floor plan layout, it is preferred that the Lunch Room is located adjacent to Gymnasium and Lobby for after-hours and assembly use when possible.
- 2.26.6 Provide washrooms located near the Lunch Room.
- 2.26.7 Confirm and co-ordinate with the Department with regard to the seating capacity and furniture requirements for the Lunch Room. Provide movable tables and chairs to accommodate full seating capacity including the provision of accessibility.
- 2.26.8 Provide designated areas for hydration stations, vending machines, a microwave station and a garbage/recycling station in the Lunch Room.
- 2.26.9 Provide one (1) hand washing station in the Lunch Room.
- 2.26.10 Provide adequate electrical and mechanical services for all equipment in the Lunch Room.
- 2.26.11 Ensure that adequate electrical capacity on dedicated circuits is available in the area of the Lunch Room designated for vending machines (refrigerated and non-refrigerated). Co-ordinate the number and type of vending machines and their electrical power requirements with the electrical capacity and the number of dedicated circuits required.

- 2.26.12 Ensure that dedicated tamper-proof duplex electrical power receptacles are located behind all microwaves.
- 2.26.13 Ensure that adequate tamper-proof duplex power receptacles are distributed around the perimeter of the Lunch Room in addition to those provided for microwaves and vending machines.
- 2.26.14 Ensure that there is adequate general lighting.
- 2.26.15 Ensure that the Lunch Room is ventilated to the outside.

## **2.27 Mechanical/Electrical Room**

- 2.27.1 Provide a Sound Transmission Rating (STC) of no less than 48 for walls, doors, floors and ceilings in the Mechanical/Electrical Room; refer to: Appendix C – Sound Transmission Ratings.
- 2.27.2 Locate Mechanical/Electrical rooms on ground floor; locate all hot water boilers on the ground floor. In floor plan layout, acoustically isolate the Mechanical/Electrical Room from instructional spaces. Confirm and co-ordinate with the Department with regard to the option of placing the Mechanical/Electrical Room in a rooftop penthouse.
- 2.27.3 Ensure the Mechanical/Electrical Rooms are not located adjacent to instructional spaces, the Administration Office, the Gymnasium, the Gymnasium Platform, the Music Room, the Staff/Teacher Preparation Room or other spaces where sound transmission will be an issue.
- 2.27.4 Provide adequate space in and adequate access to the Mechanical Room for the movement of the required personnel and equipment. Ensure that there is sufficient room around equipment for servicing and maintenance (e.g. space to remove heating coil from AHU).
- 2.27.5 Provide a double door with a removable mullion for access to the Mechanical Room for the movement of equipment.
- 2.27.6 Confirm and co-ordinate with the Department with regard to wall and floor finishes.

## 2.28 Music Room (Choral and Band)

- 2.28.1 Locate the Music Room on the ground floor in proximity to the Gymnasium. Provide access to the Music Room from the corridor through a double door with a removable mullion.
- 2.28.2 In floor plan layout, acoustically isolate the Music Room from other instructional spaces including the Gymnasium.
- 2.28.3 Provide a Sound Transmission Rating (STC) rating of not less than 60 in the operable partitions separating the Music Room from the Gymnasium Platform and other adjacent spaces (Refer to: Appendix C – Sound Transmission Ratings).
- 2.28.4 Acoustically seal doorways leading from the music room to main corridor. Provide insulated metal or solid core doors with acoustic door seals on all sides including thresholds.
- 2.28.5 Provide a clear ceiling height of not less than 3000mm.
- 2.28.6 Design ceilings, interior finishes and walls with an array of acoustically absorbent materials to reduce excessive reverberation (e.g. wall and/or ceiling-mounted or suspended absorptive or diffuser panels).
- 2.28.7 Provide music practice rooms adjacent to and with direct access to the main instructional space of the Music Room. Provide a visual connection to the main instructional space by the use of viewing windows in the practice room doors.
- 2.28.8 Ensure that all practice rooms are acoustically insulated from adjacent spaces and have a ceiling height of not less than 3000mm. Provide practice rooms with lockable (from outside only) doors and acoustic door seals on all sides including thresholds.
- 2.28.9 Confirm and co-ordinate with the Department with regard to the number and layout of risers for Choral groups in the Music Room.
- 2.28.10 Provide clear open space in the center of the main instructional area of Music Room with millwork and risers (Choral) confined to the perimeter walls.

- 2.28.11 Provide a free-standing accessible large, deep stainless steel clean-up sink (914 mm wide x 432 mm deep) with a wall-mounted faucet with swivel gooseneck spout, lever handles, aerated nozzle, and stainless steel basket strainer (Band).
- 2.28.12 Provide lockable millwork for the storage of large instruments along the perimeter walls of the main instructional area of the Music Room.
- 2.28.13 Provide shelving for the storage of small instruments along the perimeter walls of the main instructional area of the Music Room.
- 2.28.14 Provide visual and audible alarms for fire and life safety.
- 2.28.15 Provide consistent year-round temperature between 18-20 degrees Celsius and consistent relative humidity levels between 35 and 50 percent (Refer to: Appendix D – HVAC Design Guide).

**2.29 Science Laboratories - Intermediate (Grades 7-9)**

*Science Laboratories are provided for Intermediate (7-9) grade levels only (Kindergarten (K) - Primary (1-3) and Elementary (4-6) science curriculum is provided in classrooms).*

- 2.29.1 Refer to: Appendix A – Standard Layouts and Details.
- 2.29.2 Provide wall space for displays (e.g. posters etc.).
- 2.29.3 In classrooms used for science curriculum instruction provide not less than one (1) large, deep stainless steel clean-up sink (914mm wide x 432mm deep) with a wall-mounted faucet with swivel gooseneck spout, lever handles, aerated nozzle, and stainless steel basket strainer.
- 2.29.4 Provide not less than one (1) accessible sink.
- 2.29.5 Provide not less than one (1) bench with an accessible workspace.
- 2.29.6 Provide under-counter mounted sinks in laboratory benches.
- 2.29.7 Provide blackout blinds for all windows.
- 2.29.8 Ensure all tamper-proof duplex electrical power receptacles in Science Laboratories are ground fault interrupter (GFI) protected.
- 2.29.9 Provide a 200mm high platform for the instructor's bench.
- 2.29.10 Provide solid acrylic acid resistant counter and table tops.

### **2.30 Science Laboratories: Biology/Multi-Purpose**

*Biology Labs are provided for High School (Levels I-III) only.*

- 2.30.1 Refer to: Appendix A – Standard Layouts and Details.
- 2.30.2 In floor plan layout locate Biology and all Multi-Purpose Science Laboratories such that windows face south to facilitate plant growth.
- 2.30.3 Provide a built-in dishwasher.
- 2.30.4 Provide solid acrylic acid resistant counter and table tops.

### **2.31 Science Laboratories: Chemistry/Multi-Purpose**

*Chemistry Labs are provided for High School (Levels I-III) only.*

- 2.31.1 Refer to: Appendix A – Standard Layouts and Details.
- 2.31.2 Provide a lockable two-sided fume hood in the common wall between the Science Preparation/Storage Room and the Chemistry/Multi-Purpose Laboratory.
- 2.31.3 Provide lockable, ventilated, storage cabinets for flammable, acid and chemical materials in the Science Preparation/Storage Room.
- 2.31.4 Provide drench showers and eyewash stations.
- 2.31.5 Provide a built-in dishwasher.
- 2.31.6 Provide solid acrylic acid resistant counter and table tops.



### **2.32 Science Laboratories: Physics/Multi-Purpose**

*Physics Labs are provided for High School (Levels I-III) grade levels only.*

- 2.32.1 Refer to: Appendix A – Standard Layouts and Details.
- 2.32.2 Provide ceiling hooks attached to the above-ceiling building structure positioned above each mobile table for mounting overhead retractable tamper-proof duplex electrical power receptacle cord reels.
- 2.32.3 Provide solid acrylic acid resistant counter and table tops in all laboratories.

### **2.33 Staff/Teacher Preparation Room**

- 2.33.1 Ensure that there are no operable cabinets or open shelves for storage above refrigerators, stoves or sinks in kitchen millwork in the Staff/Teacher Preparation room. Above stoves, provide only a millwork cover for the exhaust fan ventilation. Above sinks, provide only a millwork cover with a light valence.
- 2.33.2 Design the layout of electrical power receptacles in the food preparation area in accordance with the standards for the design of domestic kitchens (Refer to: CEC and NBCC).
- 2.33.3 Provide accessible staff shower rooms.

## **2.34 Theatre/Drama**

- 2.34.1 Theatre/Drama instruction may be conducted in a designated instructional space at all grade levels. Confirm and co-ordinate with the Department with regard to the designation of a room for drama instruction.
- 2.34.2 Provide illumination dimmers in the room designated for drama instruction.
- 2.34.3 Provide fabric covered acoustic panels on not less than 25% of the wall space in the room designated for drama instruction.
- 2.34.4 Ensure that adequate electrical and mechanical services are provided for all equipment in the room designated for drama instruction. Provide pre-wiring for the installation of audiovisual equipment (computers, overhead projectors, sound equipment and speakers etc.); ensure that all overhead equipment is attached to the above-ceiling building structure.

### **2.35 Trades/Technology Education: Applied Technology Laboratory (Intermediate Grades 7-9)**

- 2.35.1 Locate the Applied Technology Laboratory on the ground floor with access to the outside through a double exterior door with a removable mullion. Ensure that the exterior doorway is located to facilitate supply delivery from parking lot and road access.
- 2.35.2 In floor plan layout, acoustically isolate the Applied Technology Laboratory from other instructional areas.
- 2.35.3 Divide the Applied Technology Laboratory into a Fabrication Room and a Planning Room as indicated in the standard layout. Planning room can be incorporated with the CDLI/e-Learning Computer Laboratory or the Learning Resource Centre as long as it is adjacent to and has a clear visual connection to the Fabrication Room for supervision.
- 2.35.4 Provide access from the corridor to Planning Room through 1200mm door. Provide access to the Fabrication Room only from the Planning Room through a 1200mm door.
- 2.35.5 Maximize the width of the viewing window between Fabrication Room and Planning Room to ensure visibility for supervision. Provide laminated safety glazing in all viewing windows.
- 2.35.6 Ensure that all exterior windows in the Applied Technology Laboratory are placed at not less than 2000mm from the floor. Provide internal sun screening on all exterior windows for the reduction of glare.
- 2.35.7 Confirm and co-ordinate with the Department with regard to the type and location of all equipment in the Applied Technology Laboratory.
- 2.35.8 Provide a manual emergency power shut-off switch at an easily accessible location on both the Fabrication Room side and the Planning Room side of the door between the two rooms. Ensure that all fabrication equipment in the Fabrication Room is connected to the emergency power shut-off switch. Ensure that all explosion-proof duplex

electrical power receptacles in the Fabrication Room are connected to the emergency power shut-off switch.

- 2.35.9 Provide one (1) fume hood in the Fabrication Room constructed of galvanized sheet steel and quality grade plywood.
- 2.35.10 Confirm and co-ordinate with the Department with regard to the electrical requirements for all equipment in the both the Fabrication Room and Planning Room of the Applied Technology Laboratory.
- 2.35.11 In the Fabrication Room, provide the following:
- explosion-proof duplex electrical power receptacles on dedicated circuits with 20 amp breakers for tool placement.
  - two (2) ceiling-mounted cord reels with explosion-proof duplex power receptacles (ensure that the cord reels are attached to the above-ceiling building structure).
  - light and heating fixture dust guards.
  - explosion-proof duplex electrical power receptacles for two (2) portable dust collectors.
- 2.35.12 Provide a dedicated air conditioning system in the Planning Room.
- 2.35.13 Provide a clear ceiling height of not less than 3000mm in the Fabrication Room. A dropped ceiling is required to prevent dust accumulation on open web steel joists, ductwork etc.
- 2.35.14 Provide adequate electrical power and controls for two (2) ceiling-mounted ambient air cleaners/dust collectors; ensure that all overhead equipment is attached to the above-ceiling building structure.
- 2.35.15 Provide painted concrete (not smooth) floors in Applied Technology Laboratory.

2.35.16 Provide visual and audible alarms for fire and life safety.

### **2.36 Trades/Technology Education: Skilled Trades Laboratory (High School - Levels I-III)**

- 2.36.1 Locate the Skilled Trades Laboratory on the ground floor with access to the outside through an insulated garage door located at the rear of the school and away from the main entrance to facilitate supply delivery. Provide a secondary door to the exterior in combination with the garage door.
- 2.36.2 In floor plan layout, acoustically isolate the Skilled Trades Laboratory from other instructional areas.
- 2.36.3 Divide the Skilled Trades Laboratory into a Fabrication Room and a Planning Room as indicated in the standard layout. Planning room can be incorporated with the CDLI/e-Learning Computer Laboratory or the Learning Resource Centre as long as it is adjacent to and has a clear visual connection to the Fabrication Room for supervision. Refer to Appendix A – Standard Layouts and Details.
- 2.36.4 Provide access from the corridor to Planning Room through 1200mm door. Provide access to the Fabrication Room only from the Planning Room through a 1200mm door.
- 2.36.5 Maximize the width of the viewing window between Fabrication Room and Planning Room to ensure visibility for supervision. Provide laminated safety glazing in all viewing windows.
- 2.36.6 Ensure that all exterior windows in the Skilled Trades Laboratory are placed at not less than 2000mm from the floor. Provide internal sun screening on all exterior windows for the reduction of glare.
- 2.36.7 Confirm and co-ordinate with the Department with regard to the type and location of all equipment in the Skilled Trades Laboratory.

- 2.36.8 Provide a manual emergency power shut-off switch at an easily accessible location on both the Fabrication Room side and the Planning Room side of the door between the two rooms. Ensure that all fabrication equipment in the Fabrication Room is connected to the emergency power shut-off switch. Ensure that all explosion-proof duplex electrical power receptacles in the Fabrication Room are connected to the emergency power shut-off switch (see Section 14.0).
- 2.36.9 Provide one (1) fume hood in the Fabrication Room constructed of galvanized sheet steel and quality grade plywood.
- 2.36.10 Confirm and co-ordinate with the Department with regard to the electrical requirements for all equipment.
- 2.36.11 In the Fabrication Room, provide the following:
- explosion-proof duplex electrical power receptacles (explosion-proof receptacle boxes) on dedicated circuits with 20 amp breakers for tool placement.
  - two (2) ceiling-mounted cord reels with explosion-proof duplex power receptacles; ensure that the cord reels are attached to the above-ceiling building structure.
  - light and heating fixture dust guards.
  - explosion-proof duplex electrical power receptacles (explosion-proof receptacle boxes) for two (2) portable dust collectors.
- 2.36.12 Provide a dedicated air conditioning system in the Planning Room.
- 2.36.13 Provide a clear ceiling height of not less than 3000mm in the Fabrication Room. A dropped ceiling is required to prevent dust accumulation on open web steel joist, ductwork etc..

- 2.36.14 Provide adequate electrical power and controls for two (2) ceiling-mounted ambient air cleaners/dust collectors; ensure that all overhead equipment is attached to the above-ceiling building structure.
- 2.36.15 Provide painted concrete (not smooth) floors in Skilled Trades Laboratory.
- 2.36.16 Provide visual and audible alarms for fire and life safety.



### **2.37 Vestibules**

- 2.37.1 Provide vestibules at all building entrances. Building exits do not require vestibules. Foot grilles are not acceptable.
- 2.37.2 Ensure that all lighting and other ceiling and wall-mounted fixtures and equipment is installed according to manufacturer's instructions and commissioned so as to accommodate sudden changes in air pressure due to door operation.
- 2.37.3 Ensure that all lighting fixtures in all vestibules, regardless of ceiling type, are attached to above-ceiling building structure by a safety chain or cable in addition to the primary mechanical fasteners and clips.

## 2.38 Washrooms

- 2.38.1 All student washrooms must be gender-neutral with full-height (2200mm) cubicle partitions attached to the above-ceiling building structure and mounted with a maximum clearance above the floor of 100mm.
- 2.38.2 Provide motion-activated electric fixtures with AC power and battery backup (not battery operated) for all student washrooms including toilets and sinks with motion sensor activated faucets.
- 2.38.3 Confirm and co-ordinate with the Department with regard to the number and location of owner supplied soap/paper towel/toilet tissue dispensers.
- 2.38.4 Provide low-flush, sensor controlled, wall-mounted toilets throughout the school.
- 2.38.5 Provide a separate drying area between the shower room and the dressing room in Gymnasium Change Rooms and staff shower rooms. This may be provided with a shower/change unit combination.
- 2.38.6 Provide door-less offset entrances/exits for all multiple-toilet student washrooms.
- 2.38.7 In floor plan layout, provide gender-neutral, multiple-toilet public washrooms located near the Lunchroom/Multi-Purpose Room, Gymnasium, and Lobby for use during after-hours activities.
- 2.38.8 Provide an accessible single toilet washroom with gender-neutral signage on the corridor near Administration Office and one near the Gymnasium in the after-hours use area.
- 2.38.9 Provide not less than one (1) accessible sink fitted with motion sensor activated faucets and chrome-plated off-set traps in all washrooms. Cover any exposed plumbing below the counters with vandal proof, slanted vinyl covered panels to conceal plumbing below all vanities and counters; ensure that a service panel can be removed to allow maintenance.

- 2.38.10 Provide vandal proof, slanted vinyl covered panels to conceal plumbing below all vanities and counters. Ensure that a service panel can be removed to allow maintenance.
- 2.38.11 Use sheet vinyl or ceramic tile flooring with integral baseboards.
- 2.38.12 Ensure that there are no exterior windows in washrooms.
- 2.38.13 Provide visual and audible alarms for fire and life safety.
- 2.38.14 Provide speakers connected to the Public Address system.
- 2.38.15 Provide sensors for environmental controls (no thermostats).
- 2.38.16 Provide motion-activated electric fixtures, toilets, and hand-dryers for all student washrooms.
- 2.38.17 Provide an amber coloured strobe emergency light for activation during lockdown scenarios.

## **3.0 SITE INFRASTRUCTURE**

### **3.1 Demolition/Abatement**

- 3.1.1 Confirm and co-ordinate with the Department with regard to the location and extent of any demolition and/or hazardous materials abatement required by construction activities. Ensure that demolition of existing structures and all associated hazardous materials abatement is included in the construction contract for all school projects.

### **3.2 Hoarding**

- 3.2.1 Confirm and co-ordinate with the Department with regard to the location and extent of any hoarding required by construction activities. Use temporary chain link security fencing for hoarding at all school construction projects. Ensure access to and from all exits and entrances at all times during construction activities. If during construction the temporary closure of an existing exit is required, ensure that the closure is coordinated with the Department and prepare an alternate egress plan in consultation with the School District and attain approval from the Office of Fire Commissioner (in conjunction with the St. John's Regional Fire Department for schools in the St. John's Region for inspection and verification) prior to the closure. Ensure that all alternate means of egress are available and operable during construction.
- 3.2.2 Confirm and co-ordinate with the Department with regard to the installation of permanent chain link fencing as hoarding that can be retained after construction is complete.

### **3.3 Landscaping**

- 3.3.1 Minimize slopes between changes in elevation on site. Do not terrace site landscaping.
- 3.3.2 Ensure that landscaping is designed to eliminate the need for grass mowing on steep slopes.

- 3.3.3 All new grass to be installed as sods (hydroseeding is not acceptable).
- 3.3.4 Do not use shrubs, bushes or small trees in landscaping design.
- 3.3.5 Ensure that all open site infrastructure (e.g. culverts) is enclosed by fencing or other suitable barriers to prevent student access.
- 3.3.6 Provide a flagpole near the main entrance to the school. Confirm and co-ordinate with the Department with regard to the type and location of the flagpole.
- 3.3.7 Ensure that landscaping, site and parking lot design accounts for snow clearing and dumping operations.
- 3.3.8 Provide a fixed seating area near the main entrance. Confirm and co-ordinate with the Department with regard to the location, type and number of seats provided.
- 3.3.9 Provide an “M” or wave style linear steel bike rack with mounting plates at the base; mount bike rack on a concrete pad located near main entrance.

#### **3.4 Playgrounds and Sports Fields**

- 3.4.1 Provide playgrounds for all new Kindergarten (K) - Primary (1-3) and Elementary (4-6) Schools. Confirm and co-ordinate with the Department with regard to the design of children’s play spaces and the selection of playground equipment (owner supplied). Design children’s play spaces and equipment in accordance with CSA-Z614.
- 3.4.2 Provide a fenced playground with gate adjacent to and with direct access from the Kindergarten (K) and Primary (1-3) Classrooms via a nearby exit. Provide roll-top chain link fencing to enclose playgrounds.
- 3.4.3 Provide poured or tiled rubber surface for all playgrounds in accordance with CSA-Z614.
- 3.4.4 Provide a sport/soccer field with permanent soccer/rugby net structures for all new schools.

3.4.5 Ensure that all new soccer field construction complies with the FIFA International Standard:

- 100m length x 64m width.
- provide a 3-5m safety zone around the perimeter.

If a FIFA International Standard field is not feasible, it is recommended to comply with FIFA's minimum standard:

- 90m length x 45m width.
- provide a 3-5m safety zone around the perimeter.

3.4.6 Ensure that all soccer fields crown longitudinally running from end-to-end along the centerline of the field and slope to the sides at a minimum grade of 1% and a maximum grade of 2% for drainage.

3.4.7 Ensure that soccer nets are installed according to manufacturer's instructions and are compliant with Appendix F – Soccer Net Anchoring Guidelines.

### **3.5 Parking and Bus Lanes**

3.5.1 Prepare a traffic study of surrounding thoroughfares prior to site design development.

3.5.2 Confirm and co-ordinate with the Department with regard to the number of busses and the configuration of bus lanes and drop-off points.

3.5.3 Provide separate parent/guardian vehicular and bus drop-off locations.

3.5.4 Locate the bus drop-off lane at the rear of the school on a one-way, two-lane, bus-only loop road and provide an adjacent bus parking area.

3.5.5 Locate the vehicular drop-off lane at the front of school near the main entrance on a one-way, two lane loop such

that the passenger side of vehicles faces the school main entrance. Ensure the vehicular drop-off lane does not impede the use of designated accessible parking spaces.

- 3.5.6 Design drop-off locations, lanes, crosswalks and sidewalks to minimize conflicts between vehicles and pedestrians.
- 3.5.7 Design bus lanes and drop-off points to minimize congestion in the school parking lot.
- 3.5.8 Design the parking lot configuration, traffic flow and street access so as to not interfere with traffic on adjacent thoroughfares.
- 3.5.9 Provide low back curbs for school parking lots to accommodate Accessibility. Ensure that raised traffic islands are kept to a minimum and are not located within the main parking lot area. Low back curbs are also required at all entrances and exits to the building.

### **3.6 Pedestrian Access and Walkability**

- 3.6.1 Ensure that an analysis of surrounding walkways, sidewalks, crosswalks, and traffic control and quiet measures is included in a traffic study conducted prior to site design development. Evaluate access to the proposed school site from the surrounding neighborhood from a pedestrian perspective and provide proposals for means to ensure safe access to the school site through the above mentioned methods.
- 3.6.2 Confirm and co-ordinate with the Department with regard to the parental responsibility zone (1.6 km radius) around a proposed school site within which bussing is not provided to students.
- 3.6.3 Ensure that all exits are provided with an accessible landing and ramp on the exterior of the building complete with tactile attention indicators.

### **3.7 Site Selection**

- 3.7.1 Refer to: Appendix B – Site Selection Criteria.
- 3.7.2 Confirm and co-ordinate with the Department with regard to planning for future school expansion. Ensure that the configuration of corridors and stairwells in the school floor plan and structural design can accommodate future expansion if required. Provide an indication on the school site plan (dashed lines) to show the anticipated possible size, extent, location and configuration of potential future building extension.
- 3.7.3 Ensure that applications are submitted and approvals attained from the Department of the Environment, Government of Newfoundland and Labrador regarding new school construction (e.g. with respect to encroachment on watershed areas and floodplain designations).



## 4.0 BUILDING ENVELOPE

### 4.1 Exterior Cladding

- 4.1.1 Provide durable masonry on the lower portion of the exterior wall to not more than the height of the second floor level (min. 2800mm above ground floor level). Confirm and co-ordinate with the Department with regard to approval for proposed alternate finishes.
- 4.1.2 Ensure that metal cladding on the upper portion of the exterior wall is not less than the height of the second floor level. Confirm and co-ordinate with regard to the proposal and approval for the use of alternate finishes.
- 4.1.3 Confirm and co-ordinate with the Department with regard to alternate finishes around the main entrance.
- 4.1.4 Insulated composite metal panels are not acceptable for exterior cladding on schools. Ensure that all metal cladding employed in the exterior wall assembly is of the uninsulated variety.
- 4.1.5 Ensure that the metal siding finish meets industry standards for silicone modified polyester paint.
- 4.1.6 Include quality assurance requirements in the specifications for masonry for the exterior wall cladding. Require mock-ups for inspection and approval for:
  - Appearance.
  - Consistency of color.
  - Thickness and face texture.
  - Uniformity of installation.
- 4.1.7 Confirm and co-ordinate with the Department with regard to the color of all materials prior to tender.

### 4.2 Exterior Wall Assemblies

- 4.2.1 Specify weather resistant sheathing panels.

- 4.2.2 Exterior wall assemblies constructed of steel stud with exterior gypsum sheathing panels are NOT acceptable in school construction. Exterior grade paperless glass fibre-faced gypsum board is acceptable in exterior wall assemblies ONLY as blocking/backing for vapour barrier/building paper at parapets and where needed to span structural elements.
- 4.2.3 Do NOT specify batt insulation in exterior wall assemblies.

### **4.3 Roofing**

- 4.3.1 Specify modified bitumen roofs.
- 4.3.2 Design flat roofs to positively drain to roof drains with sloped building structure where possible and tapered insulation where building structure cannot be sloped.
- 4.3.3 Design metal roofs to ensure that sliding snow will not present a hazard to the school occupants, pedestrians and vehicles. Provide snow and ice fences at the eaves of metal roofs installed as per manufacturers specifications.
- 4.3.4 Do NOT specify batt insulation in roof assemblies.
- 4.3.5 Ensure electrical conduit is not placed in the flutes of roof deck. Install electrical conduit not less than 100mm below roof deck.
- 4.3.6 Confirm and co-ordinate with the Department for the installation (type/number/location) of fall-arrest equipment/roof anchors (e.g. DBI-Sala Anchors).

### **4.4 Exterior Doors**

- 4.4.1 Specify thermally broken aluminum and/or hollow metal insulated exterior doors.
- 4.4.2 Design hermetically sealed argon filled glazing units with 6mm laminated glazing for use in exterior doors.
- 4.4.3 Confirm and co-ordinate with the Department with regard to the requirement for and location of solid metal exterior

doors without glazing. Use solid metal panels in the lower portion of all entrance/exit doors.

- 4.4.4 Confirm and co-ordinate with the Department with regard to door hardware requirements and locations. Ensure that all doors including specialty doors (e.g. roll up or sliding shutters) have cylinders that accept Best® cores.
- 4.4.5 Provide powered strikes (no powered rails) for doors where applicable. Do not employ vertical rod hardware on doors in schools.
- 4.4.6 Provide a core drilled door bollard anchored into concrete slab outside the door in areas with potential high winds.
- 4.4.7 Ensure that all exterior doors are lockable and/or equipped with alarms and are monitored to control access to the school. Confirm and co-ordinate with the Department with regard to doors that require card access control and those that do not require hardware on the exterior.
- 4.4.8 Provide an intrusion alarm system that:
  - is activated by motion and contact sensors when motion or unauthorized entry is detected;
  - is integrated with the fire alarm system;
  - is monitored by an exterior monitoring agency that can notify local authorities in the event of activation.
- 4.4.9 Provide a monitoring/control system that allows Administration Office staff to monitor and authorize access to the school at the main entrance by employing an exterior intercom system, camera and manual access control linked to the card access system.

## **4.5 Windows**

- 4.5.1 Refer to: Appendix A- Standard Layouts and Details for typical window details.
- 4.5.2 Design windows to have a bottom fixed section and an operable top hopper ventilator section. Where an operable bottom section is required to serve as a means of egress,

use only casement units with the required identifying decals and indicate handles on interior frame.

- 4.5.3 Provide one window-opening pole per classroom/space for all top hopper ventilator sections (provide an additional 5% of school total for replacements).
- 4.5.4 Ensure hardware is compatible with and integral (not surface mounted) to the operable top hopper ventilator section; provide through-frame lock hardware that is not installed after manufacture.
- 4.5.5 Provide laminated glazing for all glazing units except for the egress windows. Provide tempered glazing for egress windows.
- 4.5.6 Provide frosted glazing or film in all top section glazing units (operable and fixed) for the reduction of glare.
- 4.5.7 Design window trims and sills to eliminate sharp corners through the use of bullnose profiles.
- 4.5.8 Employ air barrier flaps fastened to the entire perimeter of the window frame and sealed to the air barrier in the exterior wall assembly.
- 4.5.9 Provide blinds for all windows in exterior walls and any clerestory/borrowed light windows in interior walls. Ensure that the blinds are mounted such that they do not conflict with the operation of the top hopper units when in the full open position.
- 4.5.10 Confirm and co-ordinate with the Department with regard to the location and type of window blinds used (provide black-out blinds in IRR/IRS). Ensure that shades meet the following standards of acceptance:
- Bacterial and fungal resistant.
  - Greenguard Gold certified (or equivalent).
  - Screen Shades:
    - 1 % Openess Factor. E.g. Weave Pro-S Series.
    - Minimum 15.04 oz/yd.
  - Blackout Shades
    - 0% Openess Factor. E.g. Weave Pro-M Series.
    - Minimum 14.46 oz/yd.

- 4.5.11 Provide frosted glazing or film on all top window lites. Ensure that glare is minimized through the use of screen shade (1% light infiltration) and/or black-out shades (0% light infiltration) roller blinds at all windows.
- 4.5.12 Ensure that all blind/curtain valences are mechanically fastened (hinges or screws) to the mounting frame (not snapped in place). Ensure all hardware (including valences) is compatible with and integral to the blind/curtain supplied (i.e. not installed after manufacture).
- 4.5.13 Provide window screens for all windows to assist with pest control.

#### **4.6 Foundation/Slab (Radon)**

- 4.6.1 Provide an active sub-slab depressurization system to control the entry of radon and soil gases into the building in all concrete basement and slab-on-grade floors. Provide an active Radon exhaust system employing an exhaust fan(s) located above the roof of the building:
  - Ensure that the pipes of this system are of a different colour than those used for building plumbing/mechanical systems for clear identification.
  - do not tie radon fan on/off controls into energy management system, but have amperage monitored to alert on fan failure
  - ensure sub-slab communication exists to permit comprehensive depressurization (i.e. multiple fans or other method of ensuring footings etc. do not interfere with full sub-slab communication). Final sign off of the radon system will not be provided until successful results are received from a 3 month winter-period test.
  - ensure radon fans configured with water bypass configuration
  - ensure radon fans appropriately supported to withstand anticipated local high wind velocity.

## **FIT-UP AND FINISHES**

### **4.7 Mold Resistant Materials**

- 4.7.1 Ensure that all materials used in school projects are free from components that support the growth of mold.
- 4.7.2 Confirm and co-ordinate with the Department with regard to the extent and location of paperless gypsum; limit use to select areas: Administration Office, Guidance Suite, Staff/Preparation Room. Ensure that only paperless, impact resistant or Very High Impact (VHI) gypsum board is used in these areas.
- 4.7.3 Ensure that all gypsum wallboards are paperless and contain mold inhibitors. Ensure that gypsum wallboards are not used for walls or ceilings in Washrooms, Change Rooms, Staff Shower rooms or other areas that are subject to high humidity conditions.
- 4.7.4 Confirm and co-ordinate with the Department with regard to the acceptability of wood in school settings. Where necessary for use as blocking or backing, use only wood preserved with a fungicide and insecticide applied with a water-repellent semi-vapor-permeable film to prevent moisture penetration.

### **4.8 Spray-on Fire Resistant Material (SFRM)**

- 4.8.1 Ensure that only cementitious spray-on fire resistant material (SFRM) products are used in schools. SFRM products shall be a mixture of gypsum and/or cement based materials with lightweight aggregates mixed with water to form slurry for conveyance and application. Mineral fibre-based products are not permitted.

### **4.9 Interior Finishes**

- 4.9.1 Provide recommended finishes for each room or type of room in the Design Development Report for review and acceptance by the Department.

- 4.9.2 Use painted concrete masonry units for all interior walls with the limited exceptions noted above in Section 4.7 and as approved by the Department.
- 4.9.3 Specify bull-nosed concrete masonry units on all corners.
- 4.9.4 Identify final finishes for exposed concrete.
- 4.9.5 Design all mechanical and electrical services to present a clean and uncluttered visual appearance in rooms where no suspended ceilings are provided. Use flat paint for exposed ceiling and all exposed mechanical and electrical equipment.
- 4.9.6 Confirm and co-ordinate with the Department with regard to the selection of flooring types, their location and durability and maintenance requirements. Ensure flooring is suitable for long-term regular cleaning using a scrubber.
- 4.9.7 Provide flooring without welded seams or seamless poured rubber (e.g. Pulastic®) flooring in the Gymnasium and Fitness Center.
- 4.9.8 Carpet and/or linoleum is NOT an acceptable flooring type for use in schools.

#### **4.10 Exposed Interior Structure**

- 4.10.1 Use flat paint for exposed building structure in interior spaces.

#### **4.11 Sound Ratings**

- 4.11.1 Provide sound transmittance ratings (STC) between rooms and adjacent spaces in accordance with Appendix C – Sound Transmission Ratings and ANSI S12.60-2002 Acoustical Performance Criteria, Design Requirements and Guidelines for Schools.
- 4.11.2 Include sound transmittance ratings (STC) for all partitions and or critical assemblies including operable partitions in the tender documents.

## 4.12 Interior Doors

- 4.12.1 All interior doors must be lockable from the inside and swing out into the corridor.
- 4.12.2 Specify solid core wood or hollow metal as required to meet fire resistance ratings and functional requirements.
- 4.12.3 Specify doors with high density particle board cores with exterior paint or stain grade veneers and solid hardwood rails, stiles and hinge and lockset blocks for solid core wood doors with a fire rating of 20 minutes or less.
- 4.12.4 Specify doors with high density mineral core with exterior paint or stain grade veneers and solid hardwood rails, stiles and hinge and lockset blocks for solid core wood doors with fire ratings between 20 and 60 minutes. Provide through bolts on all hinges and closer hardware.
- 4.12.5 Provide doors without glazing paired with sidelights employing internal mini blinds between laminated safety glazing for viewing into instructional spaces and offices.
- 4.12.6 Provide sidelights incorporating internal mini blinds between laminated safety glazing with a control knob on the inside of the room. Ensure that internal mini blinds are integral to the glazing unit (i.e. installed by manufacturer during fabrication not installed after manufacture). Ensure that interior doors without sidelights have laminated safety glazing units in the top half of the door only. Washrooms and Utility / Janitor's rooms have doors without glazing.
- 4.12.7 Coordinate overall door thickness and frame profile to accommodate glazing thickness.
- 4.12.8 Ensure that all doors including specialty doors (e.g. roll up or sliding shutters) have cylinders that accept Best® cores. Provide "intruder function" locksets for doors in all instructional spaces employing universal keying that is the same for all spaces. Provide "office function" locksets for all office spaces.
- 4.12.9 Ensure that the Gymnasium is accessible from the exterior for after-hours usage through the Main Entrance Lobby and that the classroom wings can be secured from access from the Lobby and Gymnasium during this time. Ensure



egress requirements are met throughout school during all hours.

#### **4.13 Millwork**

- 4.13.1 Provide millwork where required throughout the school except in Intermediate Classrooms (Grades 7-9) or in High School Classrooms (Levels I-III). Refer to: Appendix A – Standard Layouts and Details and TI Master Specifications regarding specific requirements.
- 4.13.2 Ensure that all cabinets in millwork are lockable.
- 4.13.3 Ensure that there are no operable cabinets or open shelves for storage above the refrigerators, stoves or sinks in the kitchen millwork. Above stoves, provide only a millwork cover for the exhaust fan ventilation. Above sinks, provide only a millwork cover with a light valence.

#### **4.14 Communication Panel-chase**

- 4.14.1 Provide a Clock/Intercom panel-chase at the front of each instructional space next to the main entrance. Provide a Data/Communications panel-chase for the control of the ITV adjacent the instructor's desk in the corner opposite the main entrance mirroring the Clock/Intercom panel-chase (Refer to: Appendix A - Standard Layouts and Details: CL 1.01-1.03 and Appendix H – Network Infrastructure Requirements).
- 4.14.2 Ensure that all data and communication for the control of the ITV and paired tamper-proof duplex electrical outlets are designed in accordance with Appendix H – Network Infrastructure Requirements.

#### **4.15 Lockers**

- 4.15.1 Provide lockers in the following quantities:
  - Kindergarten (K):  
No Lockers.

- Primary (1-3), Elementary (4-6), Intermediate (7-9) and High School (Level I-III):  
1 locker per student.
- Gymnasium Locker rooms:  
1 half locker per student based on class size (not more than 30 lockers).

- 4.15.2 Confirm and co-ordinate with the Department with regard to the numbers, types, sizes, allocation and location of lockers.
- 4.15.3 Mount lockers on metal bases; wood bases are not acceptable.
- 4.15.4 Provide lockers with integral poly vinyl chloride (PVC) drip trays (metal boot trays are not acceptable).
- 4.15.5 Mechanically ventilate lockers to control moisture. Provide lockers with perforated tops and shelves and/or a gap of approximately 25mm between the shelf and the locker door to facilitate air circulation.
- 4.15.6 Enclose top of lockers with bulkheads incorporating the return plenums for the ventilation system.

#### **4.16 Hydration Stations**

- 4.16.1 Provide not less than one (1) accessible hydration station per floor in proximity to classrooms on each floor of the school. Confirm and co-ordinate with the Department with regard to the location and travel distances to hydration stations from instructional spaces, Gymnasium, Library and after-hours use areas.
- 4.16.2 Provide an accessible hydration station near the Gymnasium, Music Room, and Lobby/Main Entrance and ensure that access to the hydration station is maintained during after-hours use without having to enter other parts of the school.
- 4.16.3 Ensure that all hydration stations are recessed in the corridor wall or located such that they do not impede or

interfere with traffic flow in the corridor but remain accessible.

#### **4.17 Interior Glazing**

4.17.1 Provide laminated safety glazing throughout the school except in windows designated for egress (use tempered glazing in all egress windows).

4.17.2 Do NOT use wired glass in schools.

4.17.3 Polycarbonate glass is not acceptable for use in schools.

## **5.0 FOOD SERVICES**

### **5.1 Equipment**

- 5.1.1 Confirm and co-ordinate with the Department with regard to food service equipment requirements and layouts.

## **6.0 CONVEYING SYSTEMS**

### **6.1 Elevators**

- 6.1.1 In multi-story buildings provide accessibility in accordance with the current editions of the NBCC, NLBAA/NLBAR, the Universal Design Standard 2021 and in accordance with CAN/CSA B651-12 Accessible Design for the Built Environment.
- 6.1.2 Provide keyed operation subject to Service NL inspection and approval.
- 6.1.3 Include interior finishes for the elevator in the Room Finish Schedule if different from those generally provided by the elevator supplier.
- 6.1.4 Provide an hydraulic passenger elevator to access all levels of the school. Provide an elevator machine room on the first floor level. Ensure that electronic monitoring is employed at all elevator pits for oil or water leaks/accumulation.

### **6.2 Stair Lifts**

- 6.2.1 Stair lifts may be considered where elevator installation in existing schools is not practical.

### **6.3 Stairs**

- 6.3.1 Ensure that all stair treads have an integral high-visibility/high-contrast strip (not tape) at the nosing.
- 6.3.2 Ensure that all stair landings incorporate tactile attention indicators in accordance with CSA B651-12.
- 6.3.3 Ensure that all stair handrails terminate in a post that extends to the floor where it is securely mounted.

## **6.4 Wheelchair Lifts**

- 6.4.1 Ensure that the entire Gymnasium Platform area can be reached by the use of an accessible ramp that wraps around the perimeter of the platform area.

## **7.0 MECHANICAL / SPRINKLERS**

### **7.1 Mechanical**

- 7.1.1 Locate all hot water boilers on the ground floor; ensure that electronic monitoring is employed for hot water boilers for leaks/accumulation.
- 7.1.2 Consider local water quality and water treatment requirements when selecting piping material.
- 7.1.3 Ensure that the water temperature in the hot water storage tank is maintained at a minimum of 60C.
- 7.1.4 Provide re-circulation pumps in the system to maintain hot water supply temperature in the event that run times become excessive.
- 7.1.5 Ensure that the maximum temperature at all lavatory tap outlets does not exceed 40C except in the Kitchen and at janitor/utility sinks. Maintain a lavatory tap outlet temperature in the range 38°C to 40°C achieved using either thermostatic mixing valves integrated into the fixture or near the fixture location.
- 7.1.6 Ensure that the mixing valves are easily accessible for maintenance.
- 7.1.7 Ensure that shower and sink hot water outlet temperatures are verified during the commissioning process.
- 7.1.8 Confirm and co-ordinate with the Department with regard to the requirement for booster pumps in locations where domestic water pressure is inconsistent or insufficient for school operation and fire protection requirements.
- 7.1.9 Provide an in-floor mop sink in the janitor's closet.

### **7.2 Sprinklers**

- 7.2.1 Ensure that flexible heads are used for the connection of all sprinklers.

### **7.3 HVAC**

- 7.3.1 Design in accordance with Appendix D – HVAC Design Guide 2023.
- 7.3.2 Ensure that all diffusers are connected to ductwork by a safety chain or cable as well as by the primary mechanical fasteners.

### **7.4 Controls**

- 7.4.1 Design in accordance with the TI HVAC Design Guide; refer to Appendix D – School HVAC Design Guide.
- 7.4.2 Provide separate thermostat and CO2 sensors (not integrated double-function control/sensor units).
- 7.4.3 Provide sensors for environmental control in washrooms (no thermostats).



## **8.0 ELECTRICAL DISTRIBUTION**

### **8.1 Performance Monitoring, Measurement and Verification**

- 8.1.1 Confirm and co-ordinate with the Department with regard to the requirement for a performance monitoring and display system utilizing input from systems meters. Ensure that the system allows input data to be provided in an interactive display at the school.
- 8.1.2 Confirm and co-ordinate with the Department with regard to the requirement for LEED Measurement and Verification. Ensure that, if required, all systems are verified and commissioned in conjunction with the building control management system (BCMS).

### **8.2 Building Power Service**

- 8.2.1 Provide 3 Phase Wye 120/208V or 347/600V building power by either overhead or underground feeds.

### **8.3 Underground Service**

- 8.3.1 Provide power via an underground utility service from an exterior pad mount transformer or by a pole-mounted distribution transformer bank supplied and installed by the electric power utility.
- 8.3.2 Provide the building electrical power service from the electrical utility transformer(s) via either pole-mounted steel conduits or directly to a duct bank from the pad mount transformer to the electrical service entrance equipment located in the main electrical room.
- 8.3.3 Ensure that the pad mount transformer is installed at a lower elevation than the electrical room to prevent water infiltration through the underground ducts.
- 8.3.4 Ensure that transformers are located so as to minimize the length of secondary conductor runs to the building and to reduce the visual impact on the site.

- 8.3.5 Ensure that the pad mount transformer, high voltage wire or cable and high voltage duct bank is supplied and installed by the electric power utility. Design the concrete pad for pad mount transformer, low voltage wire and cable, ducts, conduits, grounding, concrete and civil works to meet the requirements of the electric power utility.
- 8.3.6 Provide a high voltage underground duct bank. Ensure that the high voltage duct bank runs from a termination pole to the pad mount transformer. Provide concrete encased high voltage conductors and communications service in the high voltage duct bank.
- 8.3.7 Provide a low voltage duct bank that runs from the pad-mount transformer to the electrical room to feed the switchboard and includes provision for low voltage conductors and communication services. Ensure that the communication services ducts bypass the transformer.
- 8.3.8 Ensure that duct banks, wiring and conduits are sized in accordance with the latest edition of the Canadian Electrical Code (CEC) and provide suitable drainage.
- 8.3.9 Ensure that underground ducts are lower than interior floor level.
- 8.3.10 Ensure that underground ducts slope away from switchgear.
- 8.3.11 Provide bollards around all electrical transformers (chain-link fence enclosures are not acceptable).

#### **8.4 Dry-Type Transformers**

- 8.4.1 Provide step-down 120/208 V transformers to service receptacles and for general power requirements. Ensure that transformers have high efficiency at low loads and have a minimum K7 harmonic current capacity.
- 8.4.2 Ensure that main transformers are energy efficient as per NL Master Specification with a payback for premium extra cost in less than five years.

## **8.5 Pad-Mount Distribution Transformers**

- 8.5.1 Ensure that design provides for the installation of a pad-mount transformer supplied by the electric power utility. Locate the transformer as close as possible to the building while maintaining the required clearances. Ensure that the transformer location is lower than the main electrical room in order to prevent water entry through the service conduits.

## **8.6 Lightning Arrestor/Surge Suppression**

- 8.6.1 Provide Transient Voltage Surge Protection (TVSS) at the main switchboard and elsewhere if required.
- 8.6.2 Analyze environmental conditions and provide lightning protection where required.

## **8.7 Overhead Service**

- 8.7.1 Coordinate the location of poles and overhead service to the building with the electric power utility.

## **8.8 Service Entrance Equipment**

- 8.8.1 For schools with service entrance requirements of 120/240V, 400amp or greater, ensure that the service entrance consists of a double section service entrance switchboard incorporating a main breaker rated according to building needs, a utility metering compartment, owner's metering and circuit breaker style distribution sections.
- 8.8.2 For schools with electrical service entrance requirements of less than 120/240V, 400amp provide a proposed layout for review and approval by the Department.
- 8.8.3 Provide power monitoring through the building control system in accordance with LEED requirements. Ensure that short circuit current is calculated and the electrical power entrance equipment is rated to suit.

## **8.9 Motor Control Systems**

- 8.9.1 Provide combination motor starters for mechanical equipment as means of disconnection, performance and sequence of operation. Ensure that the electrical power supply for motor starters is not supplied from the lighting panel boards.
- 8.9.2 Provide a “Hand-Off-Auto” selector switch where a manual-automatic operation is required.
- 8.9.3 Ensure that motor starters are Electrical Equipment Manufacturers Association of Canada (EEMAC) rated and sprinkler-proof. Motor starters may be variable frequency drive if required for mechanical systems or control.
- 8.9.4 Ensure that the mechanical design includes starter size and controls for motor systems.
- 8.9.5 Group starters in Motor Control Centers (MCC) where quantity of starters justifies use of MCC.

## **8.10 Disconnect/Safety Switches**

- 8.10.1 Provide disconnect switches with following characteristics for disconnecting mechanical loads:
  - CSA Type 1 enclosure, sized as required.
  - Provision to padlock in on-off position.
  - Mechanically interlocked door.
  - Quick-make, quick-break action.
- 8.10.2 Provide general Type 1 enclosures unless indicated otherwise. Ensure that all enclosures are sprinkler/water proof and are rated as required (e.g. outdoor enclosures).
- 8.10.3 Provide a manual emergency power shut-off switch feeding a dedicated branch panel board in the Fabrication Room

and Planning Room of the Applied Technology and Skilled Trades Laboratories. Ensure that all fabrication equipment in the Fabrication Room is connected to the branch panel board. Ensure that all tamper-proof duplex electrical power receptacles in the Fabrication Room are connected to the branch panel.

8.10.4 Provide dust tight rating for electrical devices located in the Fabrication Room.

## **8.11 Equipment Enclosure**

8.11.1 Where equipment enclosures/cabinets are used, they must consist of the following:

- For Type E – sheet steel cabinet, with hinged door and return flange overlapping sides, handle, lock and catch, for surface mounting.
- For Type F – sheet cabinet, with hinged door, latch, lock, 2 keys, containing 19 mm fir plywood for surface mounting.

## **8.12 Building Wiring**

8.12.1 Provide minimum No.12AWG wire size for power or lighting circuits with minimum No.14 AWG bonding conductors.

8.12.2 Provide copper wire type with RW90 XLPE insulation.

8.12.3 Provide insulation ratings at a minimum of 600V for 347/600V AC circuits and 300 C for 120/208V circuits.

8.12.4 Provide copper or aluminum alloy conductors for feeders and branch circuits 6 AWG and larger.

8.12.5 Provide copper conductors for all service entrance feeders.

### **8.13 Junction Boxes**

- 8.13.1 Ensure that all junction boxes consist of welded steel construction with screw-on flat covers for surface mounting. Provide covers with 25mm minimum extension all around for flush-mounted pull and junction boxes.

### **8.14 Wiring Devices**

- 8.14.1 Provide adequate power for all equipment in accordance with CEC and all applicable codes. Provide tamper-proof duplex electrical outlets flush-mounted in walls throughout the school.
- 8.14.2 Provide specification grade ivory-colored wiring devices throughout the school with stainless steel cover plates.
- 8.14.3 Provide GFI receptacles or GFI breakers where ground fault protection is required.
- 8.14.4 Provide different colour electrical power receptacles for identification purposes for computers. Ensure that branch circuit neutrals are not shared for computer receptacles.
- 8.14.5 Provide a combination of occupancy sensing devices and lighting level sensors throughout the school. Ensure that these devices have the same color and grade characteristics as other wiring devices.
- 8.14.6 Provide not less than one (1) 15A, 120V circuit for every two (2) classrooms for the general electrical power receptacle layout.
- 8.14.7 Ensure that the total number of lights per circuit does not exceed the total for three (3) classrooms. Include voltage drop considerations during design layout.
- 8.14.8 Provide circuits exclusively dedicated for Gymnasium lighting only.

## **8.15 Circuit Breakers**

- 8.15.1 Provide bolt-on molded case breakers in all distribution panels. Ensure that multiple breakers have a single handle and that tie-bars are not used.
- 8.15.2 Provide a solid-state molded case circuit breaker operated by means of solid-state trip with associated current ITV and single phase protection for the main service-entrance circuit breaker.
- 8.15.3 Provide a lock on devices for essential circuit breakers (e.g. emergency and exit lighting).

## **8.16 Conduits**

- 8.16.1 Provide conduit not less than 19mm in diameter unless otherwise indicated in the NL Master Specification.
- 8.16.2 Provide thin wall EMT for above ground conduit where used.
- 8.16.3 Provide Polyvinyl Chloride (PVC) conduit for all underground and in-slab conduit (in-slab conduit may be flexible PVC).
- 8.16.4 Ensure that where feeder conduits are grouped, all feeders are in separate conduits.
- 8.16.5 Ensure electrical conduit is not placed in the flutes of roof deck. Place electrical conduits 100mm below roof deck.

## **8.17 Grounding**

- 8.17.1 Provide ground conductors and equipment that include the following:
  - Copper ground bus in the main electrical room and second floor electrical room.
  - Compression type ground bus connections.

- Copper ground conductors.
- Communications ground bus at the incoming communication service location and in each communication distribution location.
- A separate ground wire for all conduits.

Ensure that the electrical service is grounded to the building ground.

8.17.2 Provide rod electrodes for main ground. Provide a single main ground to the building with a neutral conductor grounded to the main ground only.

8.17.3 Ensure that the main ground is connected to the building structural steel and to the street side of the metallic water main if available.

## **8.18 Heating**

8.18.1 The method of heating shall be the dependent on the location and type of school. Confirm and co-ordinate with the Department with regard to the type and method of heating selected for individual new school projects and ensure that approval is attained for the design of any and all heating systems employed in schools. Design heating systems in accordance with the BBB.

## **8.19 Electric Heaters**

8.19.1 Provide commercial grade electric heaters installed in such a way so as to discourage standing or sitting on them. Ensure that electric heaters are manufactured of a durable metal gauge to resist damage due to scratching or denting.

## **8.20 Heat Pumps**

8.20.1 If chosen as the method of heating, design the heat pump system to supply heat to the building for the majority of the



heating cycle. Provide electric heaters to provide the necessary makeup heating in peak demand periods when supplemental heating is required.

- 8.20.2 Provide heating controls, power supply and control wiring as required.

## **8.21 Snow Melt Cables / Heat Trace**

- 8.21.1 Confirm and co-ordinate with the Department with regard to the requirement for the installation and location of snow melt cables and heat tracing at canopies, roofs, gutters, down spouts, rainwater leaders and any other locations where ice may accumulate.

## 9.0 ELECTRICAL LIGHTING

### 9.1 Lighting

- 9.1.1 Provide motion activated fixtures and/or tamper resistant switches (in stairway and corridors) for all lights throughout schools.
- 9.1.2 Ensure that glare is minimized through the use of diffuser louvers on the ceiling-mounted lighting fixtures
- 9.1.3 Provide recessed light emitting diode (LED) lighting units in T-bar ceilings throughout the school (with the exception of high-ceiling spaces such as stair wells, atria and the Gymnasium). Provide high performance lamps with electrical drivers to match.
- 9.1.4 Confirm and co-ordinate with the Department with regard to the number, type and location of occupancy and daylight photo sensors for the control of the illumination system.
- 9.1.5 Provide wall-mounted lighting fixtures in high-ceilinged areas such as atria and stairwells at not less than 2500mm above floor level to avoid tampering and not more than of 3000mm above floor level for ease of servicing. Ensure that wall-mounted lighting fixtures do not provide a deep horizontal ledge that can be tampered with or that has a tendency to collect dust.
- 9.1.6 Provide light-emitting diode (LED) exterior building and site lighting. Ensure that sufficient building-mounted and pole-mounted exterior LED lighting is provided to illuminate parking areas, access routes and selected walkways. Ensure that all exterior lighting is controlled via the building control management system (BCMS) or by daylight photo sensors with the provision for manual override or a time clock.
- 9.1.7 Provide LED lighting for all School Gymnasium Platforms. (Refer to: Appendix A- Standard Layouts and Detail). Co-ordinate supports with tie-back to building structure and ensure sign-off by the structural engineer of record is attained.

- 9.1.8 Provide LED lighting in the Gymnasium that does not require protective cages: minimum 14 ga. thick aluminum housing w/ powder coat finish; Polycarbonate diffused, clear acrylic lens (no glass in housing or lenses); c/w protective lens with minimum lumen rating of 18,000.
- 9.1.9 Design all lighting to the BBB/LEED Guidelines to minimize energy requirements and environmental impact.
- 9.1.10 Ensure that all lighting diffuser grilles are connected to the lighting fixture by a safety chain or cable as well as by the primary mechanical fasteners. Ensure that lighting fixtures in T-bar ceiling grids are secured with fastening clips.
- 9.1.11 Ensure that all lighting fixtures, regardless of ceiling type, are attached to above-ceiling building structure by a safety chain or cable in addition to the primary mechanical fasteners and clips including in main entrance vestibule and all secondary vestibules.

## **10.0 ELECTRICAL EMERGENCY POWER**

### **10.1 Emergency Backup Power**

- 10.1.1 Confirm and co-ordinate with the Department with regard to the requirement for emergency back-up power in rural locations.

## 11.0 COMMUNICATIONS, DATA AND SECURITY

### 11.1 Intercom System

- 11.1.1 Provide an integrated Intercom/Public-address/Clock/Program Bell System throughout all schools. Ensure the system includes the following components:
- Microprocessor based master controller located in the Administration Office with readily available access by office staff.
  - Head end equipment and controls for the intercom/clock/program bell system and background input devices.
  - Intercom stations with speaker and talk-back capability-mounted in instructional spaces and all areas where talk-back/paging is required.
- 11.1.2 Provide a secondary intercom call button in classrooms (wireless option is acceptable).
- 11.1.3 Provide an integrated Intercom/Public Address/Clock-Program Bell System panel-chase in all instructional spaces adjacent to the main exit door (mirroring an identical chase on the same wall in the opposite corner adjacent the instructor's desk for data and power outlets). Refer to: Appendix A- Standard Layouts and Details: CL 1.01-1.03.

### 11.2 Public Address System

- 11.2.1 Provide a public address system throughout all occupied spaces in schools with paging speakers mounted in the corridors and washrooms as part of the integrated Intercom/Public Address that is controlled from the Administration Office.
- 11.2.2 Provide a separate public address system in the Gymnasium including an amplifier and mixer with background music source inputs and microphones.

Ensure that the microphone inputs are located in the gymnasium walls. Ensure that the Gymnasium public address system is integrated with the Intercom/Public Address system throughout the school so that both systems can be used for total building mass notification.

- 11.2.3 Ensure that the public address system is integrated with an ASSISTED listening device sound system in the Gymnasium and all large assembly spaces in accordance with NBCC.
- 11.2.4 Ensure that all wiring and cabling for the Intercom/Public Address system is installed in conduit. Ensure that all systems cabling is designed and installed in accordance with system manufacturer's specifications.
- 11.2.5 Provide speakers connected to the Public Address system and visual and audible alarms for fire and life safety in all washrooms.

### **11.3 Central Clock System**

- 11.3.1 Provide a programmable clock and bell system as part of the integrated Intercom/Public Address system throughout the school with exterior bells for program signals and program signals inside the school via system speakers. Provide clocks in each instructional space, classroom, corridor, the Lunch Room and the Gymnasium. Ensure that all clocks are synchronized and controlled by master clock in the master controller at the Administration Office.
- 11.3.2 Locate clocks in an integrated Intercom/Public Address/Clock-Program Bell System panel-chase in each instructional space adjacent to the main exit door.
- 11.3.3 Provide digital clocks throughout the school at all grade levels.

### **11.4 Television System**

- 11.4.1 Confirm and co-ordinate with the Department with regard to the requirement for the provision of television service in schools. Ensure that television cable service enters the building underground and is routed in conduit to a

distribution panel-mounted on a plywood backboard located in close proximity to the telephone service entrance. Ensure that the system is routed to individual power outlets in instructional spaces and selected work areas.

11.4.2 Provide fire-rated TV cable run in ceiling spaces and neatly bundled and supported. Ensure that cable is run in conduit from ceiling directly to outlet box or data port/drop at the instructor's computer location.

11.4.3 Provide a video display system with monitors placed in all Corridors and the Lobby for the display of school announcements, video messages etc. Ensure that all video display monitors are interactive and able to be controlled from inputs from the Administration Office and are linked to the main cable TV system. Ensure that all video display monitors are installed on adjustable mounting systems. Confirm and co-ordinate with the Department with regard to the number and location of video display monitors to be provided in the corridors. Provide video display monitors of the designated size in the following locations:

All Corridors and Lobby - 812mm (32");  
Lunch/Multipurpose Room - 812mm (32");  
Staff/Teacher Preparation Room - 560mm (22").

## **11.5 Security System**

11.5.1 Provide a card access reader throughout the school in accordance with Appendix I – Card Access Control System).

11.5.2 Supply a Closed Circuit Television system throughout the school in accordance with Appendix J – Closed Caption Television System. Ensure that the CCTV system capable of being monitored from the Administration Office.

11.5.3 Provide a Security System at the main doors, bus drop-off doors, dumpster door, playground door, and fitness room door.

- 11.5.4 Provide an intrusion alarm system including motion sensors on the main floor hallways, door contacts, alarm sirens and keypad control units. Motion sensors are not required in upper level hallways nor in any classrooms; glass breakage sensors are not required.
- 11.5.5 Ensure that the intrusion alarm system is zoned and partitioned to permit after-hours use and that it is possible to disable the intrusion alarms for the Gymnasium and any other identified after-hours use areas separately from the remainder of the school. Provide a separate security keypad for Gymnasium/after-hours use areas.
- 11.5.6 Provide remote monitoring of the intrusion and fire alarm system through a contract with a monitoring agency.

## **11.6 Data System**

- 11.6.1 Provide a fully operational data system in accordance with Appendix H – Network Infrastructure Requirements.
- 11.6.2 Confirm and co-ordinate with the Department with regard to the numbers and locations of in-class computers and Interactive Televisions (ITV) including those computers at stations in the center of instructional spaces e.g. science labs etc.. Refer to: Appendix A – Standard Layouts and Details.
- 11.6.3 Coordinate the height of electrical and data connections with the location of wall-mounted video display monitors, Interactive Television (ITV) speakers, cameras and other electric equipment.
- 11.6.4 Provide tamper-proof duplex electrical power receptacles paired with all data ports/drops.

## **11.7 Wireless Access Points**

- 11.7.1 Provide wireless access points as to provide full coverage to all areas of the school. Refer to: Appendix H – Network Infrastructure Requirements.



## **11.8 Interactive Televisions**

- 11.8.1 All instructional spaces shall be designed to include an Interactive Television (ITV); see Section 2.0).
- 11.8.2 Design for the installation of the Interactive Television at the front and center of all instructional spaces such that windows are not directly behind the students but are flanking the right side of the desk orientation. Provide adequate clear wall space for the installation of the ITV between other wall-mounted items e.g. white boards and tack boards. Ensure that the ITVs are visible from all student locations and that interference due to glare is minimized.
- 11.8.3 Refer to Appendix H – Network Infrastructure Requirements for technical requirements for connections, mounting heights, data, electrical, etc.

## **11.9 Gymnasium Sound System**

- 11.9.1 Confirm and co-ordinate with the Department with regard to the type of performances that are anticipated to occur on the Gymnasium Platform and ensure that the sound system for the Gymnasium and Gymnasium Platform is compatible with and suitable for the intended use.

## **11.10 Gymnasium Platform Lighting**

- 11.10.1 Provide a theatrical style lighting system for the Gymnasium Platform. Provide LED and dimmable spotlight type down-lights directly over the Platform. Provide LED and dimmable spotlights in the ceiling of the Gymnasium aimed at the Platform.
- 11.10.2 Provide a single lighting bar with two portable spotlights for the Platform in Kindergarten (K) - Primary (1-3) and Elementary (4-6) Schools.
- 11.10.3 Provide two lighting bars - one at the front and one at center of the Platform in Intermediate (7-9) and High Schools (Level I-III).

- 11.10.4 Ensure that all lighting for the stage is capable of being controlled from the Gymnasium Platform or with a remote controller that can plug into the system at strategic points in the gym. Provide house lights to illuminate the Platform when it is not in use for performances.

## 11.11 Telephone Systems

- 11.11.1 Provide telephone outlets at the following locations:

Principal's Office (desk)  
Vice Principal's office (desk)  
Administration Office (reception desk + two desk locations)  
Staff/Teacher Preparation (wall-mounted)  
Instructional Resource Suite (wall-mounted)  
Mechanical Room (wall-mounted)  
Gymnasium Instructor's Office (desk)  
Lunch Room (wall-mounted)  
Kitchen (wall-mounted)  
Library (circulation desk)

- 11.11.2 Provide fax outlets at one location in the Administration Office.

- 11.11.3 Ensure that the telephone system is installed in accordance with the requirements of the local communications utility service provider. Ensure that the telephone system includes the following:

- Telephone service entrance conduit run underground from termination structure to a distribution panel on wall-mounted plywood backboard in the Main Electrical Room.
- Electrical power receptacles for telephone equipment in the Main Electrical Room.
- Outlet boxes and telephone power outlets.
- Conduit system and all telephone wiring.

- Ground bus for telephone installer's use adjacent to telephone service entrance area inclusive of #6AWG ground wire from the ground bus to the main system ground.
- Bonding of all telephone conduits to the ground bus.

11.11.4 Provide both landline and network communication connections for all security systems.

### **11.12 Assisted/Enhanced Listening Systems**

11.12.1 Provide an ASSISTED listening device sound system (microphone, amplification, transmitter-receiver, personal – use headsets and speakers) in the Gymnasium and all large assembly spaces in accordance with NBCC.

11.12.2 Provide an ENHANCED listening sound system (microphone, amplification and speakers) in all instructional spaces; see Section 2.0).

### **11.13 Uninterruptible Power Supply**

11.13.1 Provide an uninterruptible power supply (UPS) and network switches for the Intercom/Public Address system and all direct digital control (DDC) components for the energy management system in schools.

## **12.0 LEED**

- 12.1.1 Establish all targeted LEED Credits during the Pre-design Phase of the project and design to achieve the identified credits.

## 13.0 COMMISSIONING

### 13.1 Structural Commissioning

- 13.1.1 Design and commission all supports, connections and mounting conditions to ensure structural sign-off is attained from the structural engineer of record for all equipment including but not limited to:

- Stage lighting bars.
- Stage curtain and supports.
- Stage hoisting equipment.
- Basketball nets and backstops.
- Gymnasium divider curtains.
- Fall-arrest/roof anchor system.

Ensure that structural testing is included as part of the Commissioning process. Ensure that a second structural testing of basketball net systems is scheduled to be conducted 1 month after school opening.

- 13.1.2 Ensure that all overhead equipment is attached to above-ceiling building structure.
- 13.1.3 Ensure that all lighting fixtures, regardless of ceiling type, are attached to above-ceiling building structure by a safety chain or cable in addition to the primary mechanical fasteners. Ensure that all lighting diffuser grilles are connected to the lighting fixture by a safety chain or cable as well as by the primary mechanical fasteners. Ensure that lighting fixtures in T-bar ceiling grids are secured with fastening clips.
- 13.1.4 Ensure that all HVAC system diffusers are connected to ductwork by a safety chain or cable as well as by the primary mechanical fasteners.

### 13.2 Training Schedules

- 13.2.1 Confirm and co-ordinate with the Department with regard to the scheduling of training sessions during Commissioning. Ensure that A MINIMUM OF 48 HOURS OF ADVANCE NOTICE is provided to prior to the

scheduling of training sessions conducted during  
Commissioning.

## **14.0 FURNITURE & EQUIPMENT**

### **14.1 Owner Supplied Furniture and Equipment**

- 14.1.1 Confirm and co-ordinate with the Department with regard to all owner- supplied furniture and equipment requirements.
- 14.1.2 Confirm and co-ordinate with the Department with regard to the space and service requirements of all owner-supplied furniture and equipment.
- 14.1.3 Confirm and co-ordinate with the Department with regard to the installation of Interactive Televisions (ITV) in all instructional spaces (Refer to: Appendix H – Network Infrastructure Requirements).

### **14.2 Contractor Supplied and Installed Furniture and Equipment**

- 14.2.1 Confirm and co-ordinate with the Department with regard to all contractor supplied furniture and equipment requirements.
- 14.2.2 Confirm and co-ordinate with the Department for space and service requirements of all contractor supplied furniture and equipment.
- 14.2.3 Include catalogue cuts in an appendix to the tender documents for all furniture and equipment included in the construction contract.
- 14.2.4 Confirm and co-ordinate with the Department with regard to the seating capacity requirement and the number and dimensions of chairs requiring storage underneath the Gymnasium Platform. Ensure that there is adequate capacity on dollies underneath the Gymnasium Platform to accommodate the maximum seating capacity for the Gymnasium as determined by the fire regulations.
- 14.2.5 Supply an itemized listing of each room and what furniture and equipment therein will be contractor supplied.

## **APPENDICES**









## **APPENDIX A – STANDARD LAYOUTS AND DETAILS**

A100 – Legend  
A101 – Coat Rack  
A102 – Art Room - Elevation  
A103 – Canteen - Plan & Elevation  
A104 – Classroom - Elevation - Data/Comm. Panel  
A105 – Classroom - Elevations - Data/Comm. Panel  
A106 – Home Economics - Plan  
A107 – Home Economics - Plan  
A108 – Home Economics - Plan  
A109 – Home Economics - Plan  
A110 – Home Economics - Plan  
A111 – Home Economics - Plan  
A112 – IRS - Plan – Washroom  
A113 – IRS - Elevation  
A114 – Kindergarten Classroom - Plan  
A115 – Kindergarten Classroom - Elevation  
A116 – Kitchen/Servery - Plan  
A117 – Kitchen/Servery - Plan  
A118 – Kitchen/Servery - Plan  
A119 – Kitchen/Servery - Plan  
A120 – Music Room - Elevation  
A121 – Primary 1 to 3 Classroom - Plan & Elevation  
A122 – Elementary 4 to 6 Classroom - Plan & Elevation  
A123 – Science Lab & Preparation - Plan  
A124 – Science Lab & Preparation - Plan  
A125 – Science Lab & Preparation - Elev.  
A126 – Science Lab & Preparation - Elev.  
A127 – Staff/Teacher Preparation - Plan & Elevation  
A128 – Staff/Teacher Preparation - Plan & Elevation  
A129 – Staff/Teacher Preparation - Plan & Elevation  
A130 – Staff/Teacher Preparation - Plan - Wash. /Shower  
A131 – Skilled Trades - Plan  
A132 – Skilled Trades - Elevation  
A133 – Skilled Trades - Elevation  
A134 – Section - Millwork  
A135 – Section - Millwork  
A136 – Section - Millwork  
A137 – Section - Millwork  
A138 – Section - Millwork  
A139 – Section - Millwork  
A140 – Section - Millwork  
A141 – Section - Millwork  
A142 – Section - Millwork  
A143 – Section - Millwork  
A144 – Section - Millwork

- A145 – Section - Millwork
- A146 – Section - Millwork
- A147 – Section - Millwork
- A148 – Section - Millwork
- A149 – Section - Millwork
- A150 – Section - Millwork
- A151 – Section - Millwork
- A152 – Section - Millwork
- A153 – Section - Millwork
- A154 – Section - Millwork
- A155 – Classroom - Details - Data/Comm. Panel
- A156 – Window - Elevation
- A157 – Window - Egress - Elevation
- A158 – Window - Egress - Decal

## LEGEND

GB1 GRAB BAR TYPE 1  
 GB2 GRAB BAR TYPE 2  
 GB3 GRAB BAR TYPE 3  
 TB TOWEL BAR  
 M MIRROR  
 PTD PAPER TOWEL DISPENSER  
 SD SOAP DISH  
 RH ROBE HOOK  
 FSS FOLDING SHOWER SEAT  
 WB WASTE BASKET  
 TTD TOILET TISSUE DISPENSER  
 SND SANITARY NAPKIN DISPOSAL  
 LSD LIQUID SOAP DISPENSER  
 S SHELVING  
 CT CURTAIN TRACK  
 SC SHOWER CURTAIN AND ROD

 RECEPTACLE  
 C  RECEPTACLE (CEILING MOUNTED)  
 F  RECEPTACLE (FLOOR MOUNTED)  
 P  RECEPTACLE (PEDESTAL MOUNTED)  
 DATA OUTLET  
 SWITCH  
 WBD WHITEBOARD  
 TBD TACKBOARD  
 FE FIRE EXTINGUISHER

	<b>project</b> SCHOOL PLANNING MANUAL	<b>date</b> 22/12/16
	<b>title</b> LEGEND	<b>drawing no.</b> A100 Rev. 1

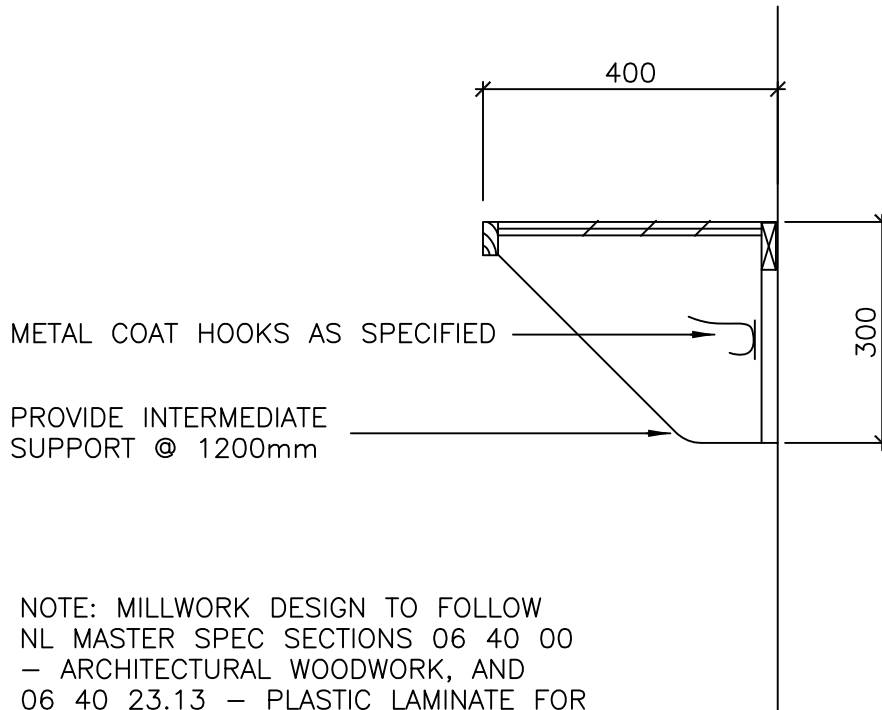

NOTE: MILLWORK DESIGN TO FOLLOW  
 NL MASTER SPEC SECTIONS 06 40 00  
 – ARCHITECTURAL WOODWORK, AND  
 06 40 23.13 – PLASTIC LAMINATE FOR  
 INTERIOR ARCHITECTURAL WOODWORK

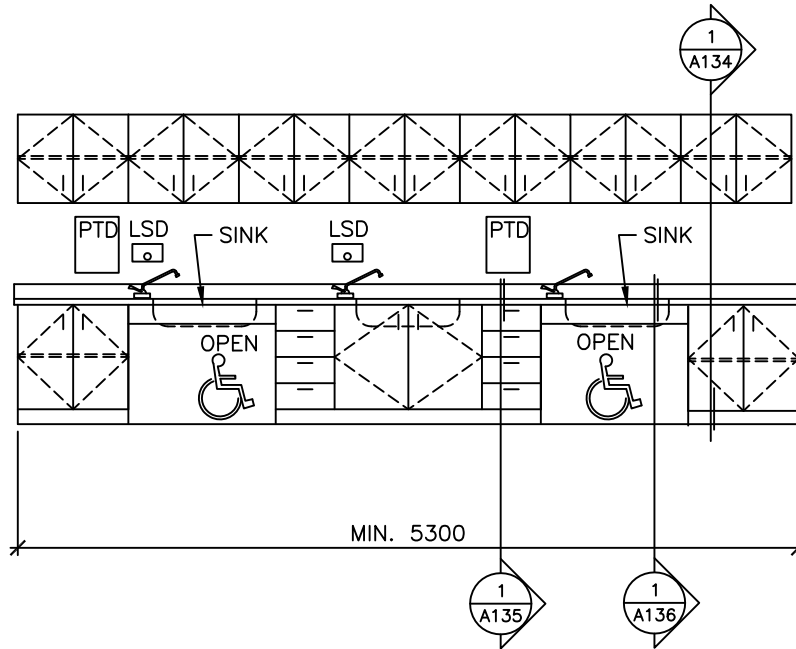

NOTES:

1. ALL CABINET DOOR AND DRAWERS TO HAVE LOCKS (TYP.)
2. ALL SINKS TO HAVE OFFSET TRAPS.

ELEVATION – CABINETS

SCALE 1 : 50

1  
A102

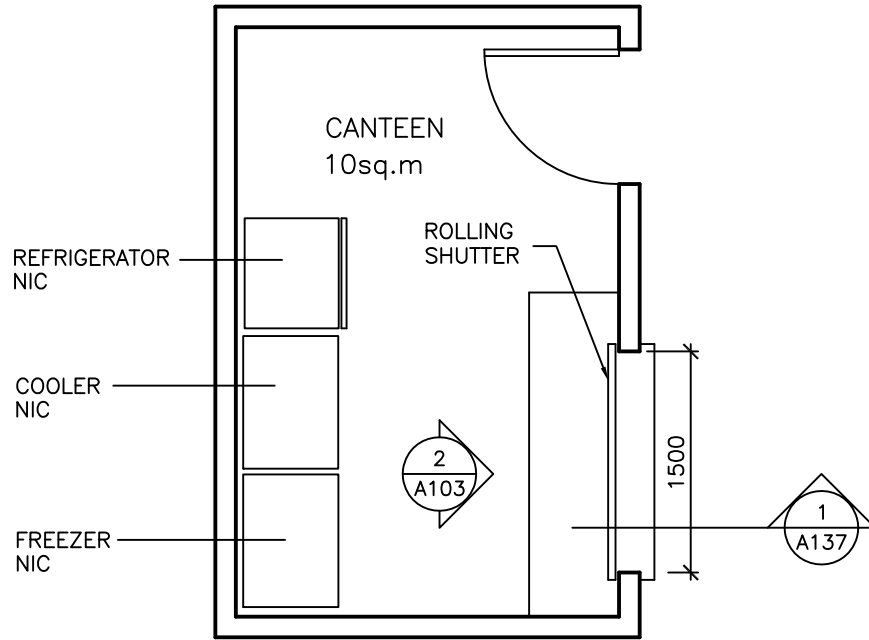

**PLAN-LAYOUT**

SCALE 1: 50

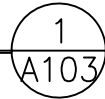

ALL CABINET DOOR AND DRAWERS TO  
HAVE LOCKS (TYP.)

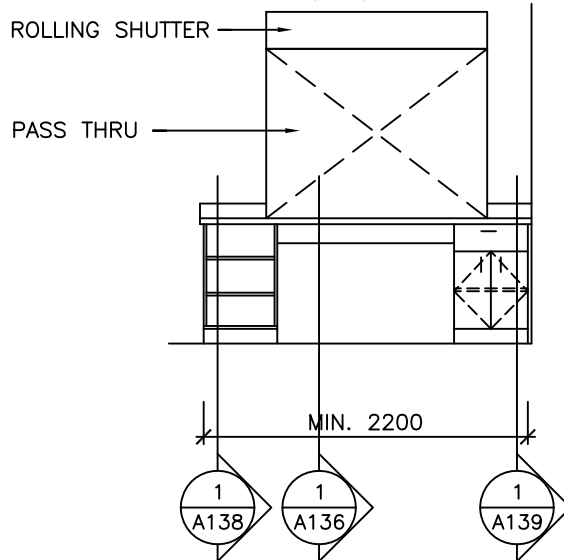

**ELEVATION - CABINETS**

SCALE 1 : 50

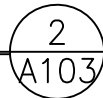

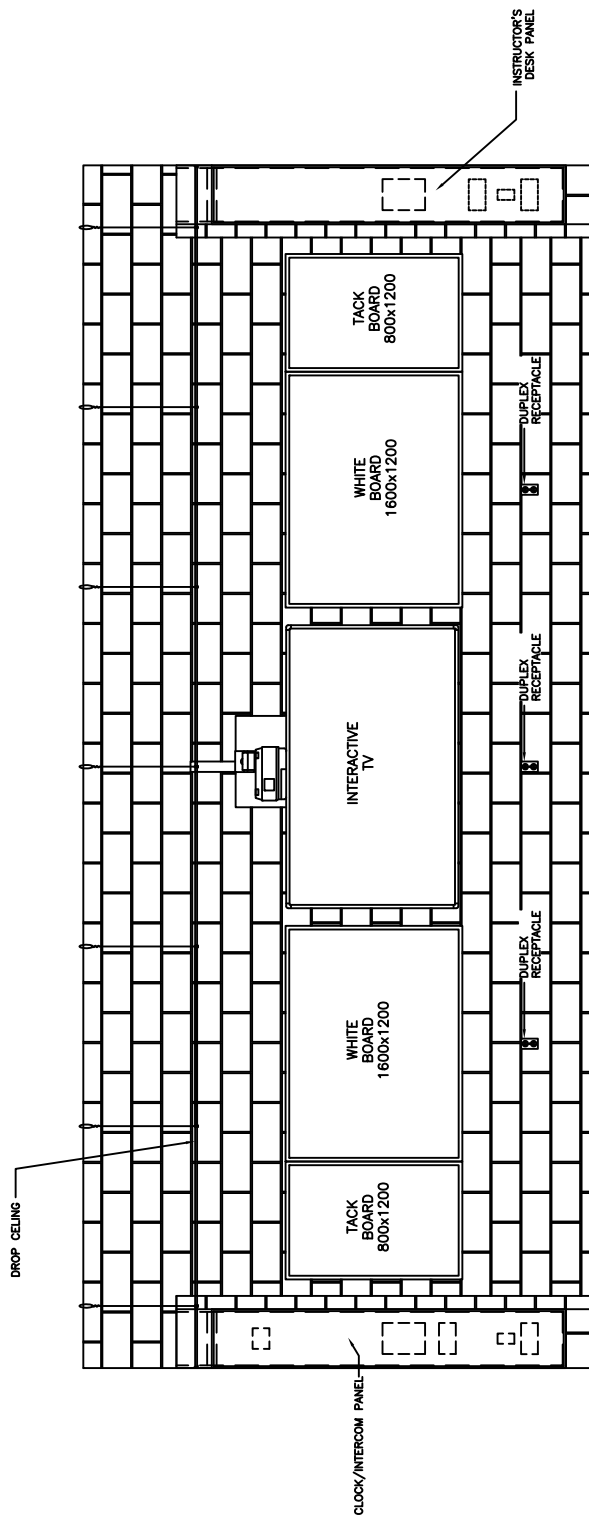

1  
A104

ELEVATION – PANELS

SCALE 1 : 50

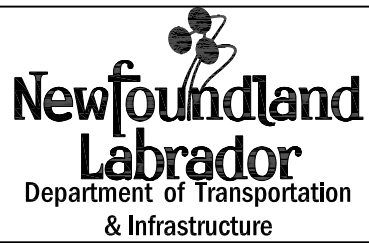

project  
SCHOOL PLANNING MANUAL

title  
ELEVATION  
CLASSROOM DATA/COMM. PANEL

date  
2022/12/16

drawing no.  
A104



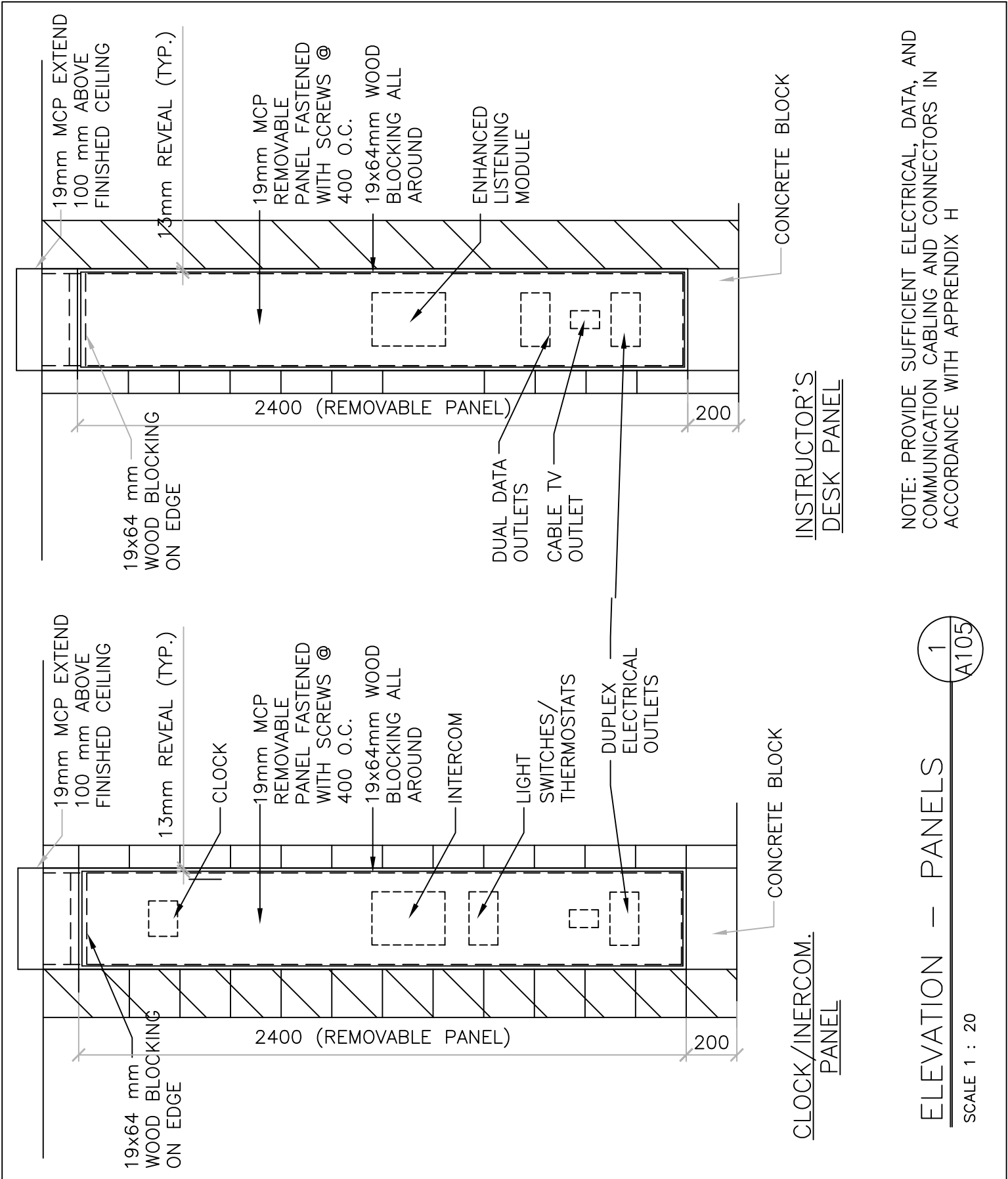

NOTE: PROVIDE SUFFICIENT ELECTRICAL, DATA, AND COMMUNICATION CABLING AND CONNECTORS IN ACCORDANCE WITH APPENDIX H

1  
A105

ELEVATION -- PANELS

SCALE 1 : 20

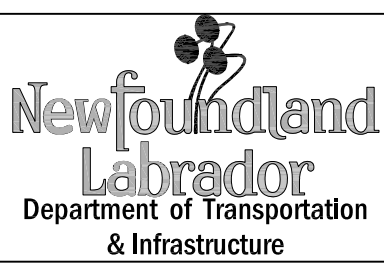

project  
SCHOOL PLANNING MANUAL

title  
ELEVATIONS  
CLASSROOM DATA/COMM. PANEL

date  
2022/12/16

drawing no.  
A105

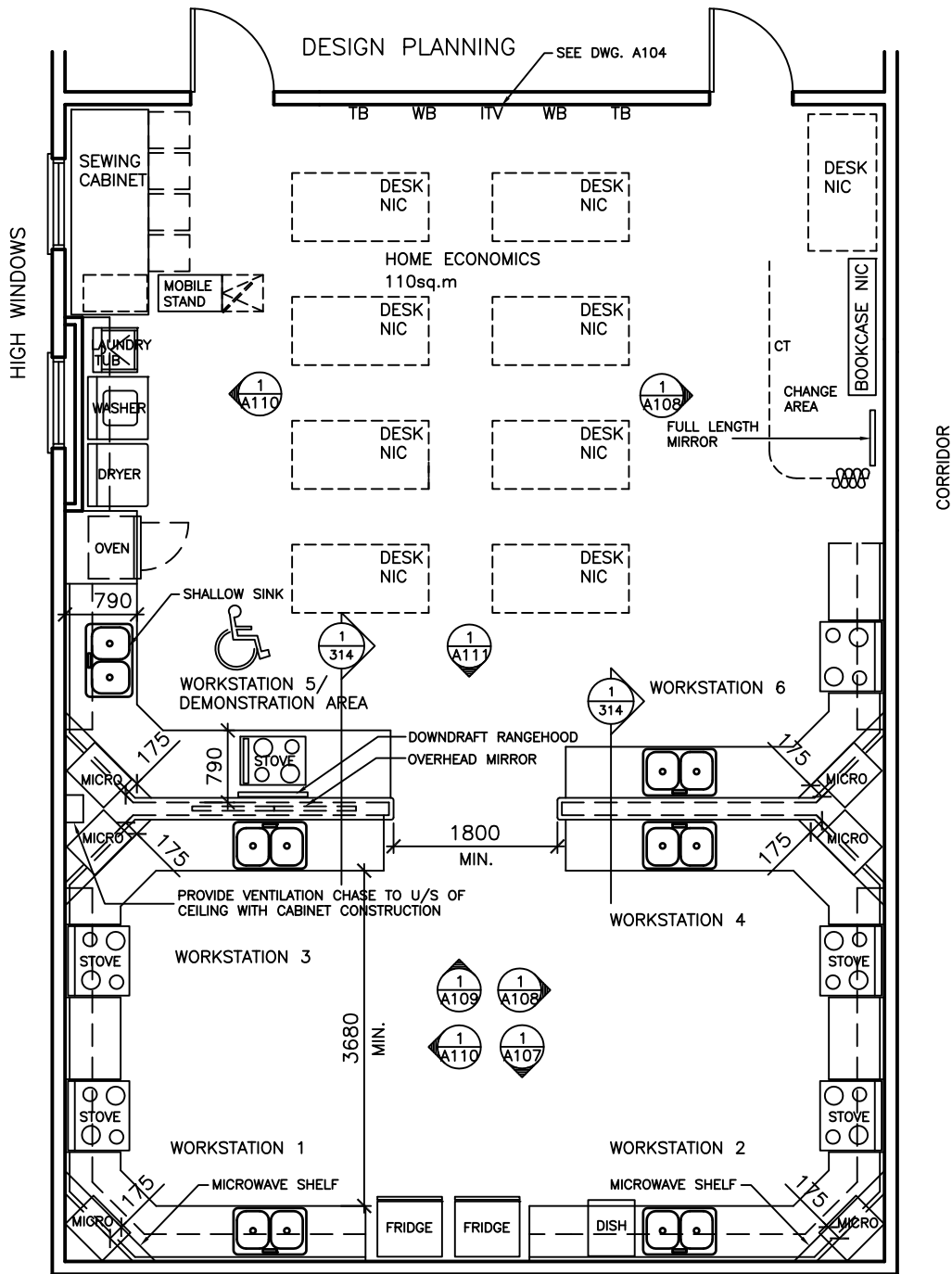

PLAN-LAYOUT

SCALE 1: 75

1  
A106

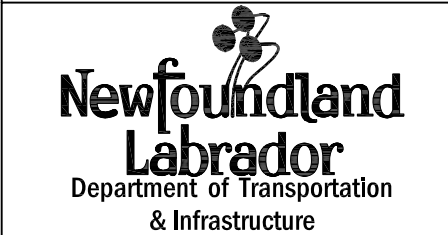

project  
SCHOOL PLANNING MANUAL

date  
2022/12/16

title  
PLAN - HOME ECONOMICS

drawing no.  
A106  
Rev. 4

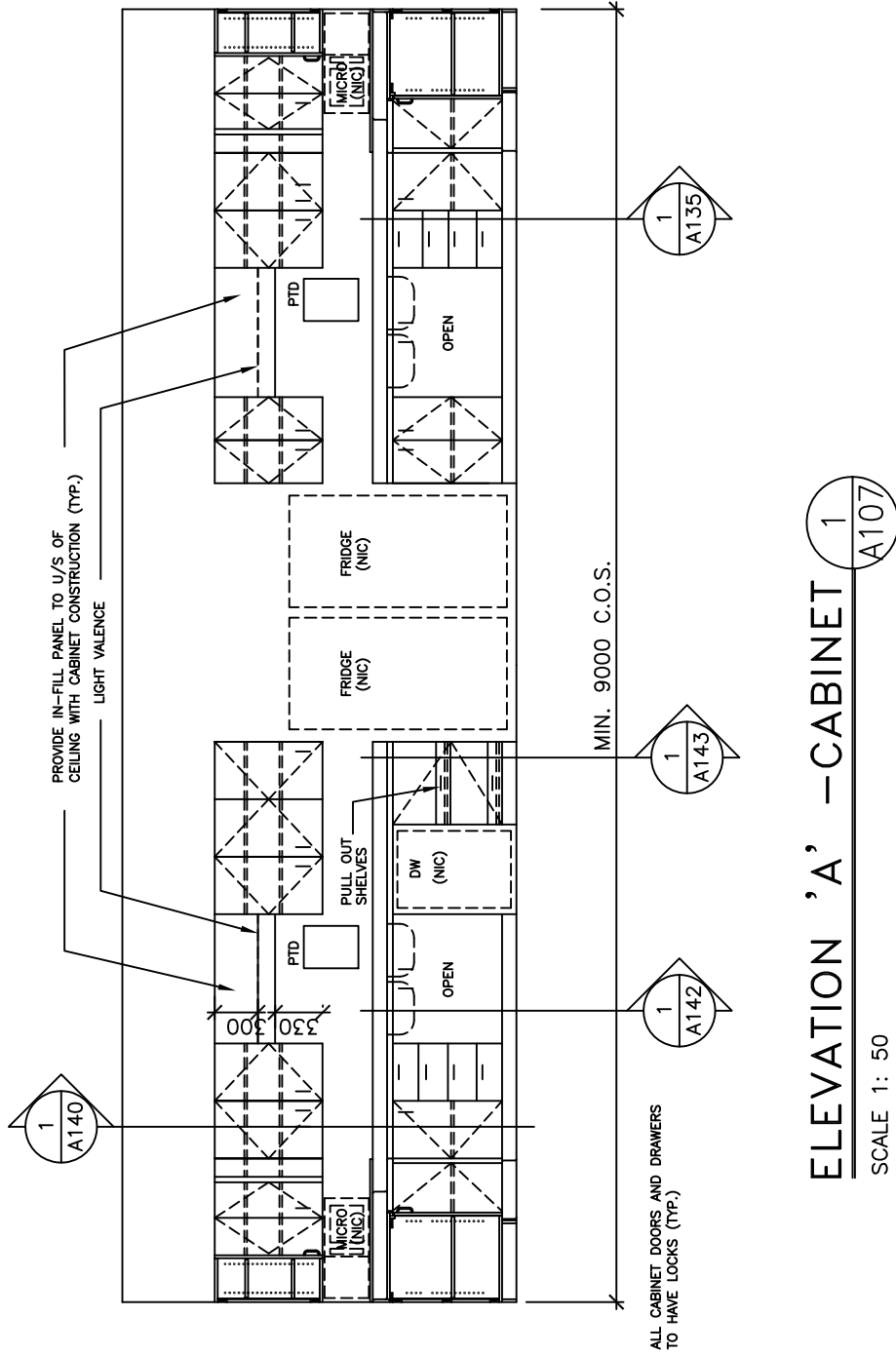

ELEVATION 'A' - CABINET  
SCALE 1: 50



project  
SCHOOL PLANNING MANUAL

date  
2022/12/16

title  
ELEVATION -  
HOME ECONOMICS

drawing no.  
A107  
Rev. 4

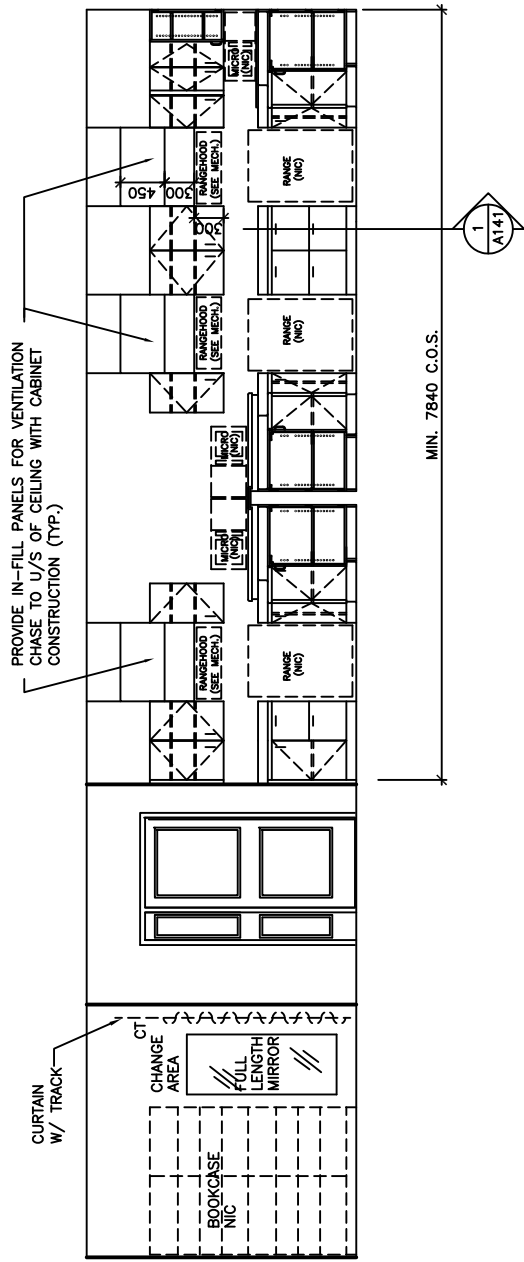

ELEVATION 'B' - CABINET

SCALE 1: 75

1  
A108

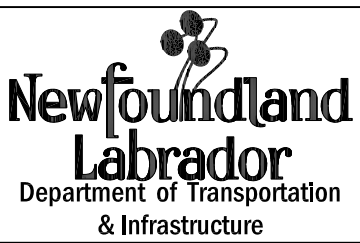

project  
SCHOOL PLANNING MANUAL

title  
ELEVATION -  
HOME ECONOMICS

date  
2022/12/16

drawing no.  
A108  
Rev. 3

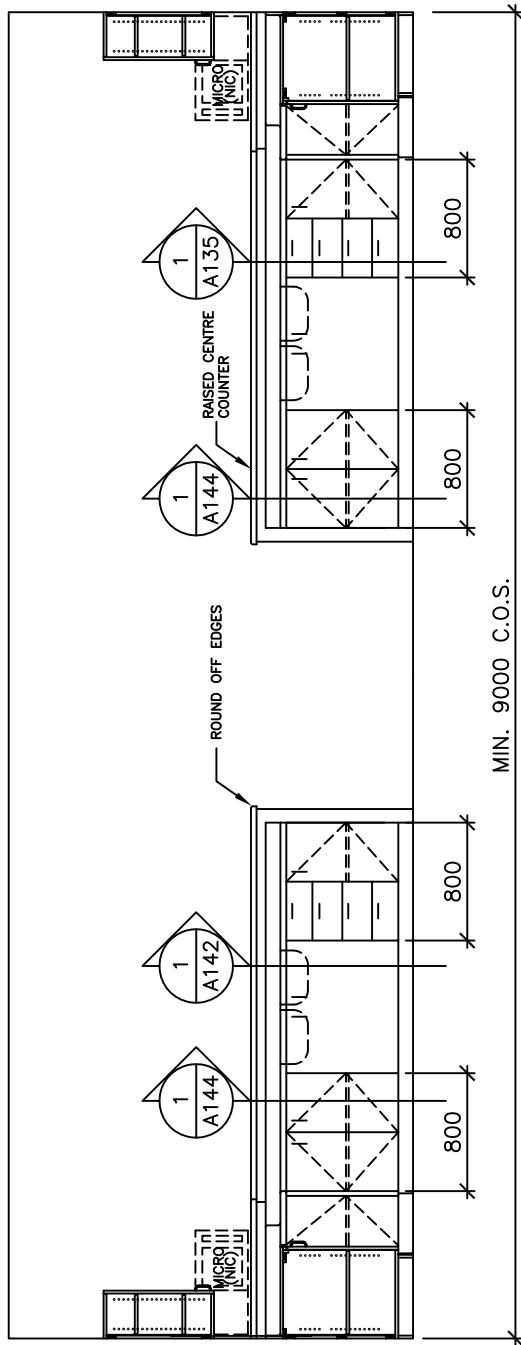

ELEVATION 'C' - CABINET 1  
A109

SCALE 1: 50



project  
 SCHOOL PLANNING MANUAL

date  
 2022/12/16

title  
 ELEVATION -  
 HOME ECONOMICS

drawing no.  
 A109  
 Rev. 3

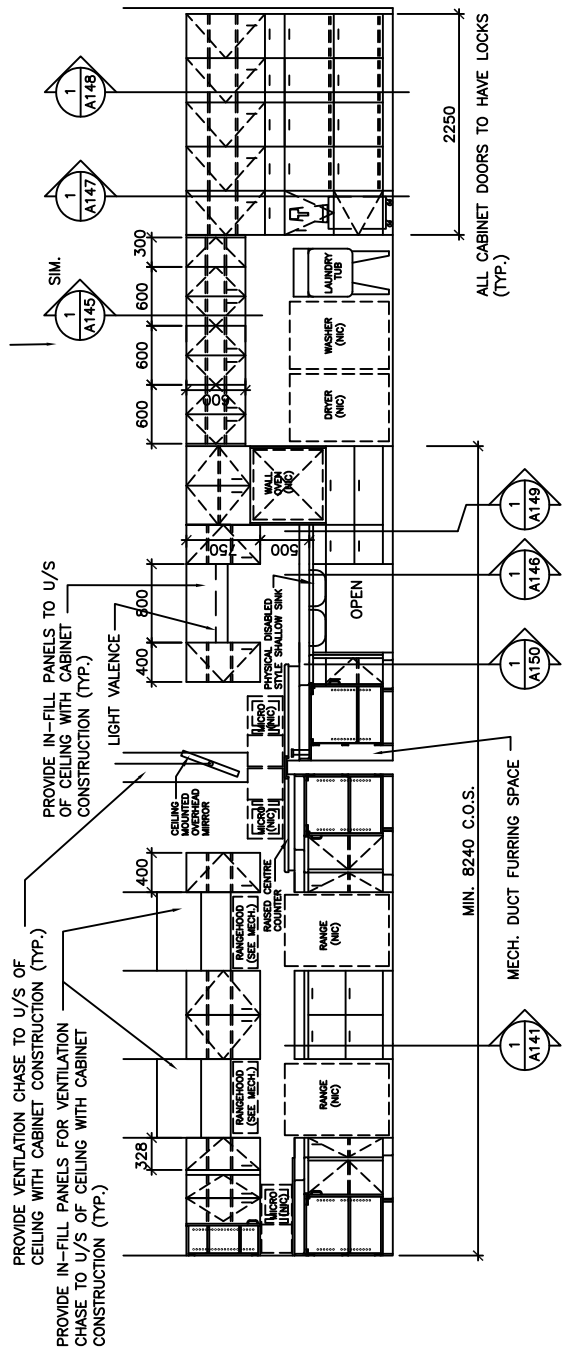

ELEVATION 'D' – CABINET 1  
A110

SCALE 1: 50

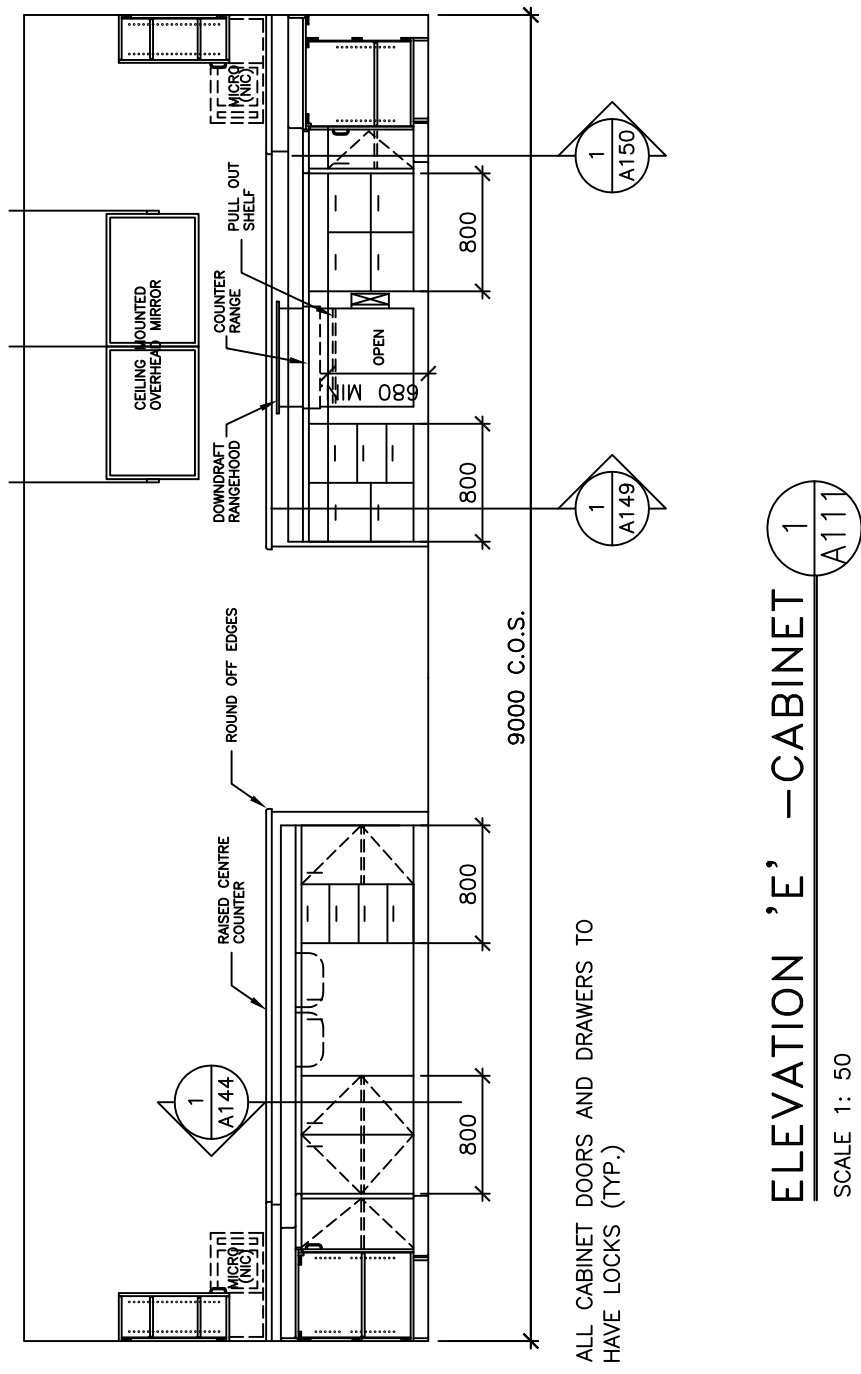

ALL CABINET DOORS AND DRAWERS TO HAVE LOCKS (TYP.)

ELEVATION 'E' - CABINET

SCALE 1: 50

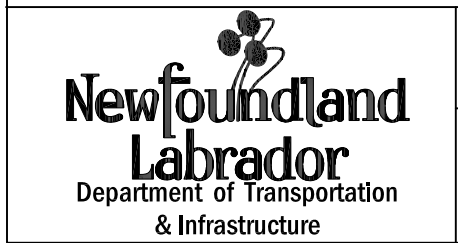

project  
SCHOOL PLANNING MANUAL

title  
ELEVATION - HOME ECONOMICS

date  
2022/12/16

drawing no.  
A111  
Rev. 3

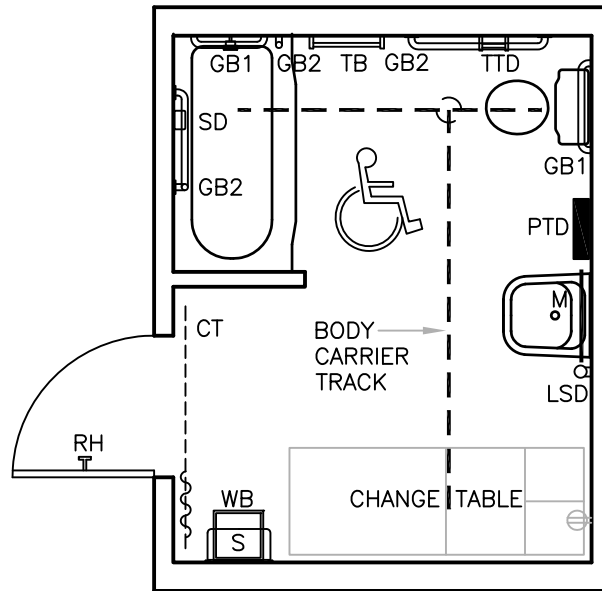

PLAN-LAYOUT-OPTION A

SCALE 1: 50

1  
A112

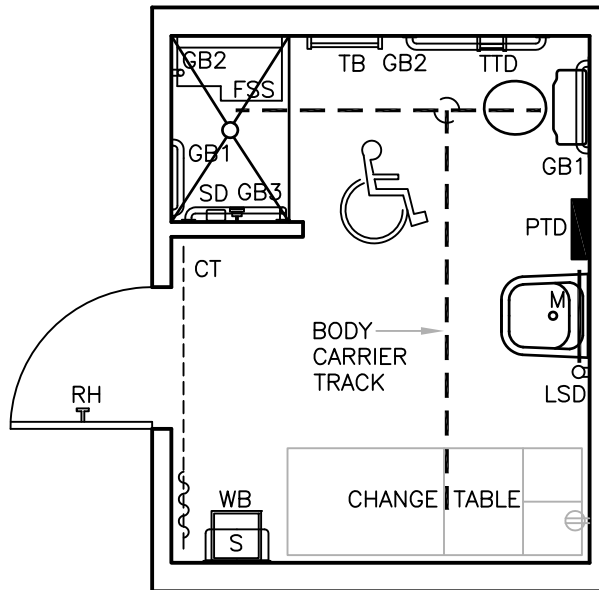

PLAN-LAYOUT-OPTION B

SCALE 1: 50

2  
A112



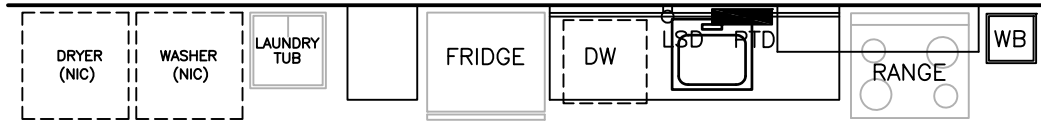

# PLAN-LAYOUT

SCALE 1: 50

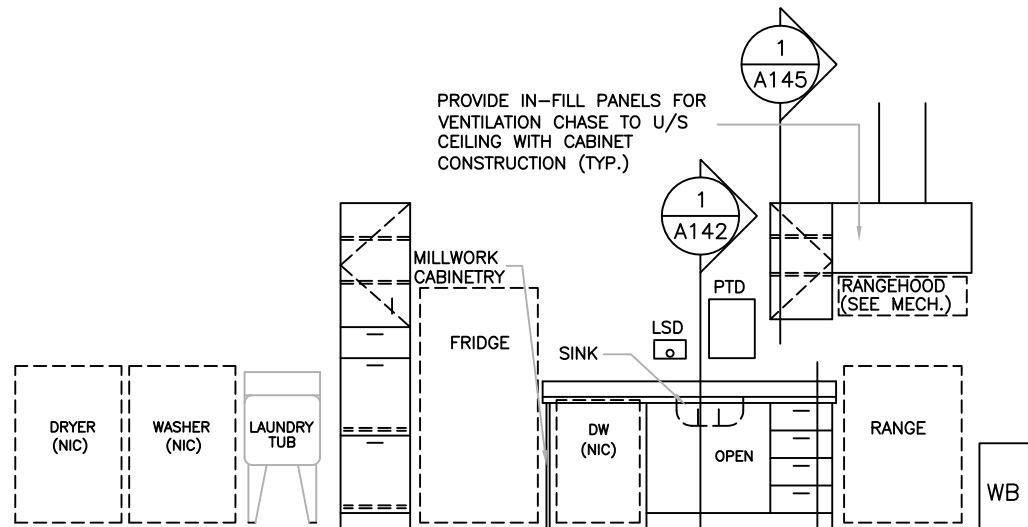
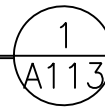

ALL CABINET DOOR AND DRAWERS TO HAVE LOCKS (TYP.)

# ELEVATION - CABINET

SCALE 1: 50

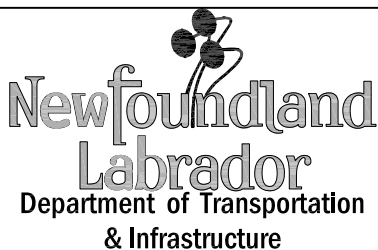

project  
SCHOOL PLANNING MANUAL

title  
PLAN - ELEVATION  
INSTRUCTIONAL RESOURCE SUITE

date  
2022/12/16

drawing no.  
A113  
Rev. 1

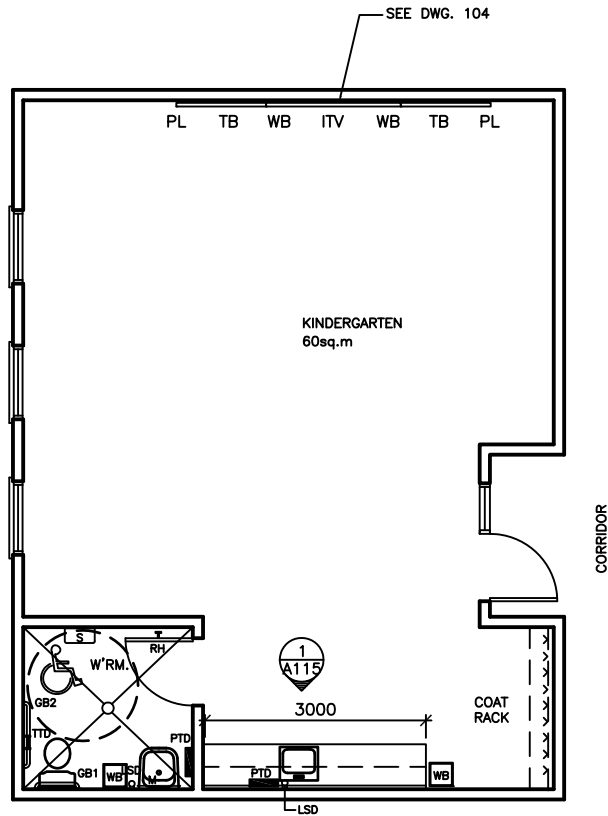

PLAN-LAYOUT

SCALE 1: 100

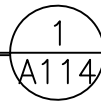

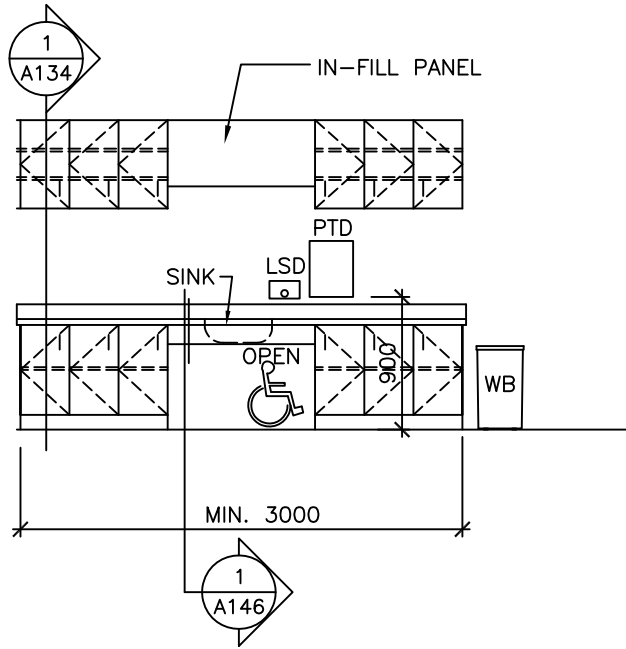



ALL CABINET DOOR AND DRAWERS  
TO HAVE LOCKS (TYP.)

## ELEVATION — CABINETS

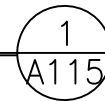
SCALE 1 : 50



	<b>project</b> SCHOOL PLANNING MANUAL	<b>date</b> 2022/12/16
	<b>title</b> ELEVATION KINDERGARTEN CLASSROOM	<b>drawing no.</b> A115 Rev. 3

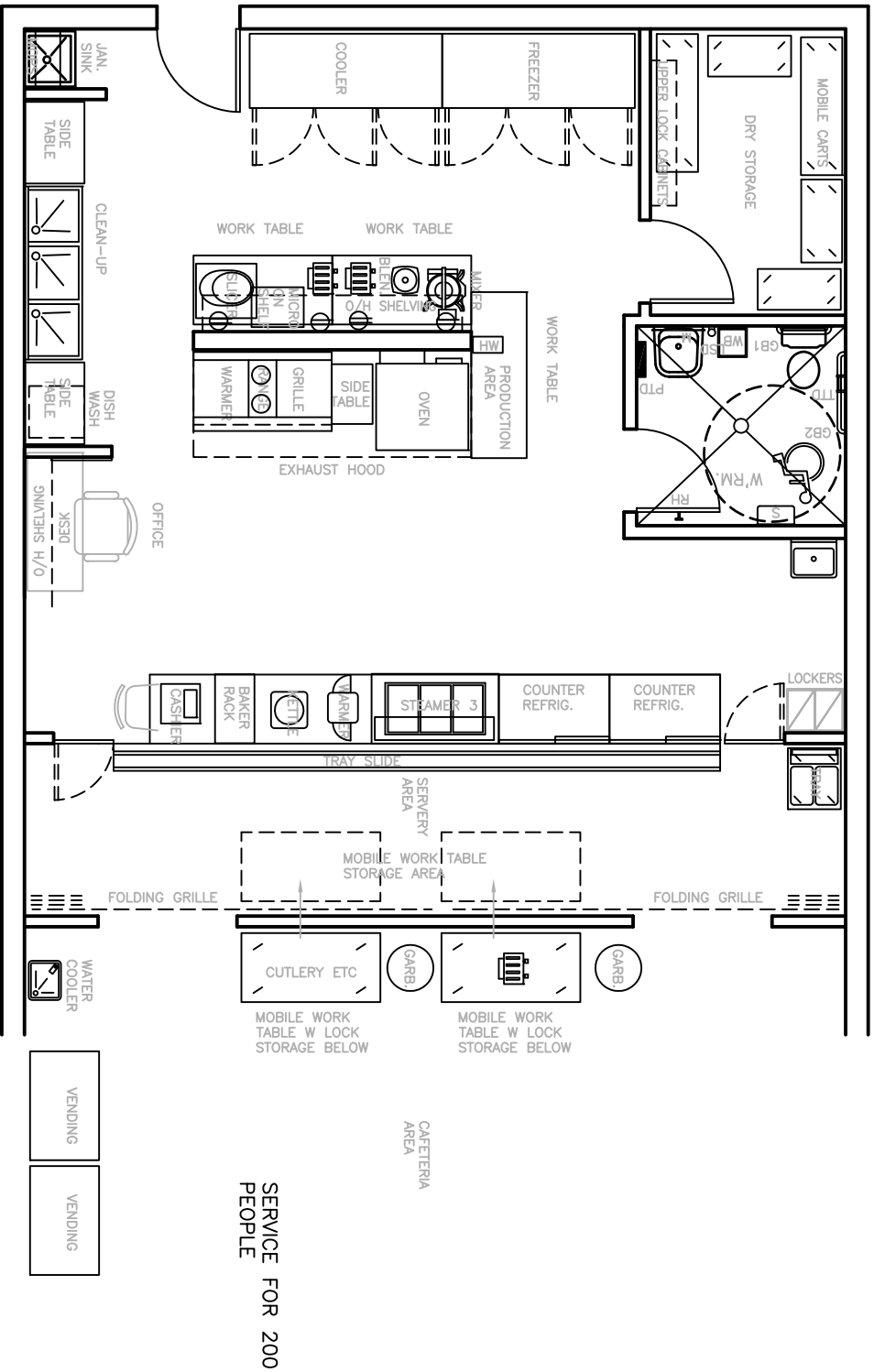

	<b>project</b>	SCHOOL PLANNING MANUAL	<b>date</b>	2022/12/16
	<b>title</b>	PLAN – KITCHEN/SERVERY	<b>drawn</b>	
			<b>drawing no.</b>	A116



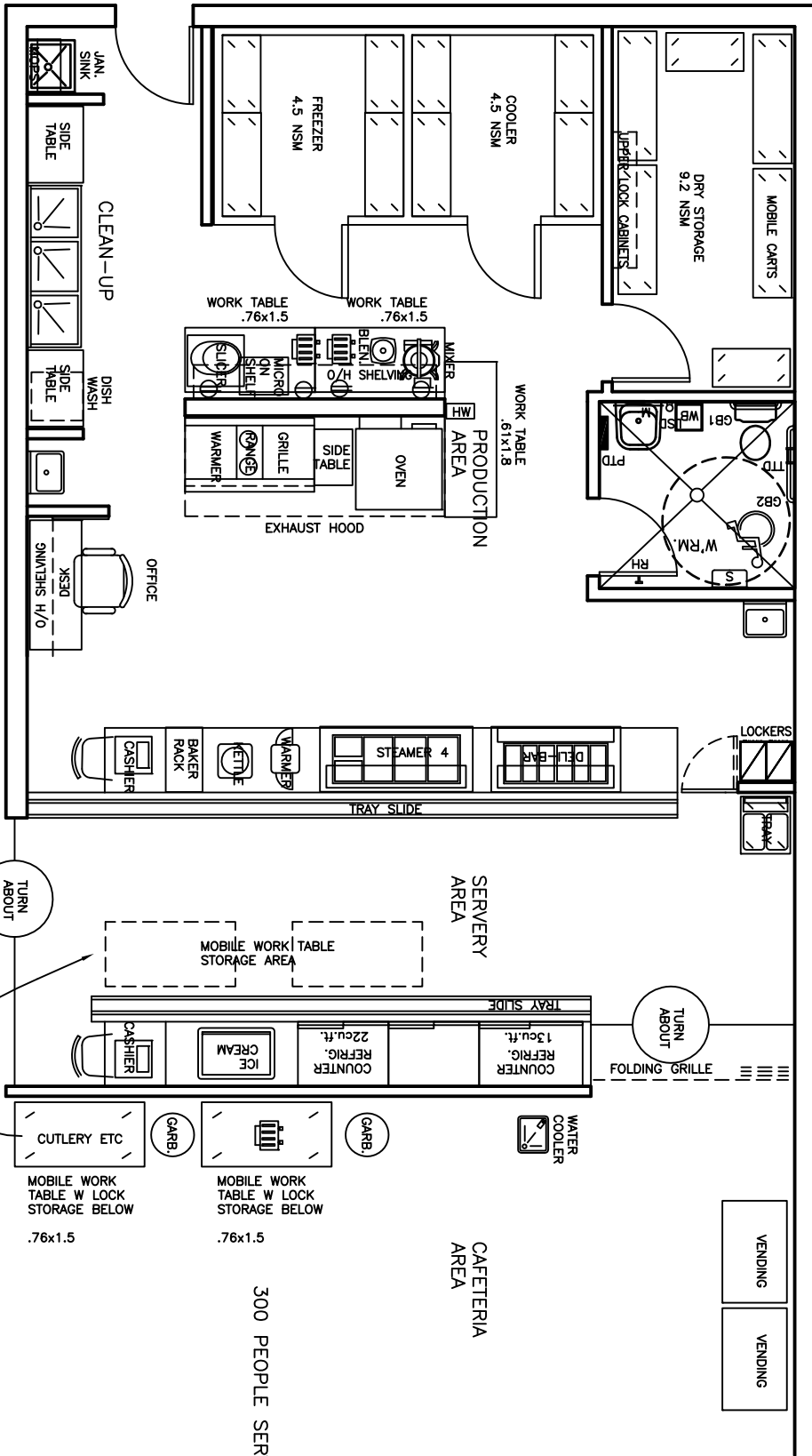

**Newfoundland**  
**Labrador**  
 Department of Transportation  
 & Infrastructure

project  
 SCHOOL PLANNING MANUAL

title  
 PLAN - KITCHEN/SERVERY

date  
 2.07.2012/12/16

drawing no.  
 A118

300 PEOPLE SERVICE

CAFETERIA AREA

SERVERY AREA

- MOBILE WORK TABLE W LOCK STORAGE BELOW .76x1.5
- MOBILE WORK TABLE W LOCK STORAGE BELOW .76x1.5

VENDING VENDING

TURN ABOUT

TURN ABOUT

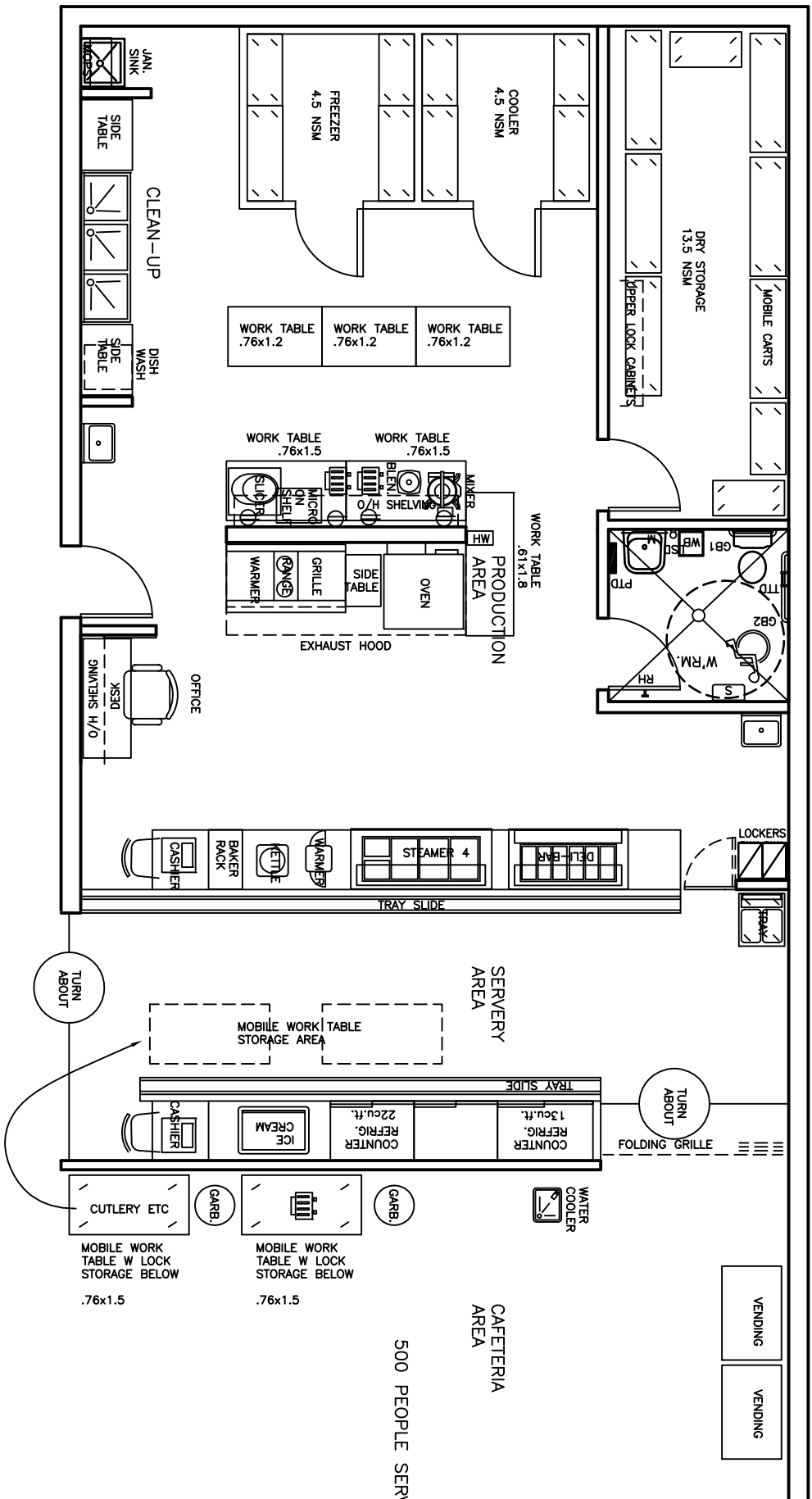

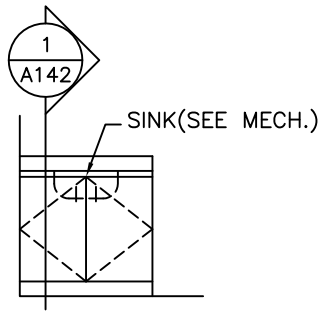

## ELEVATION – CABINETS

SCALE 1 : 50

1  
A120

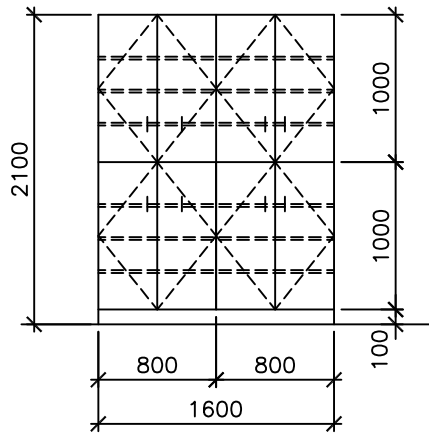

ALL CABINET DOORS TO HAVE LOCKS (TYP.)

## ELEVATION – CABINETS

SCALE 1 : 50

2  
A120



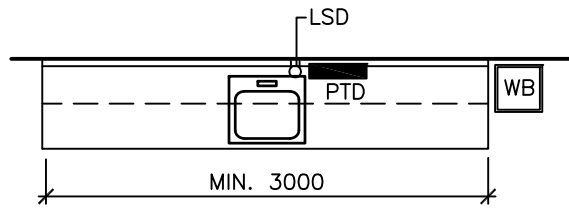

**PLAN – CABINETS**

SCALE 1: 50

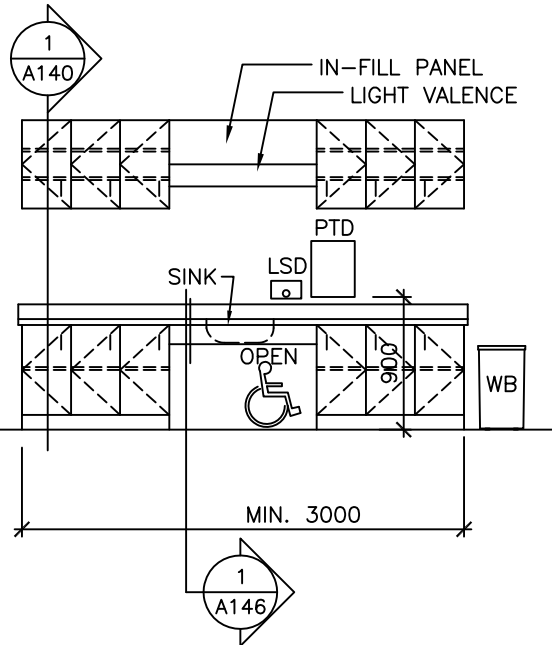
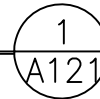

ALL CABINET DOOR AND DRAWERS  
TO HAVE LOCKS (TYP.)

**ELEVATION – CABINETS**

SCALE 1: 50

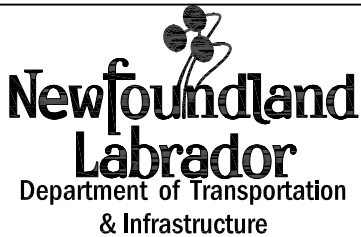
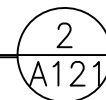

project  
SCHOOL PLANNING MANUAL

date  
2022/12/16

title  
PLAN & ELEVATION  
PRIMARY 1 to 3 CLASSROOM

drawing no.  
A121  
Rev. 3

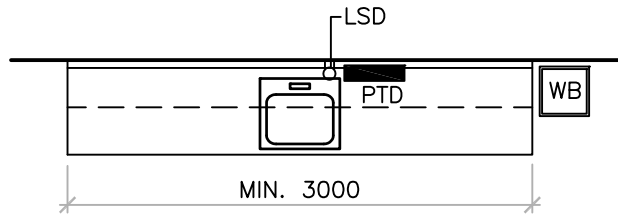

# PLAN – CABINETS

SCALE 1: 50

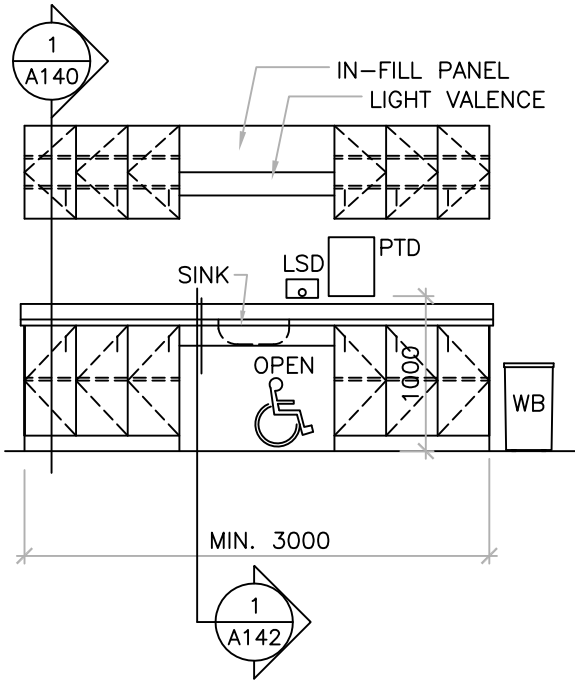
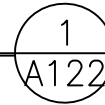

ALL CABINET DOOR AND DRAWERS TO HAVE LOCKS (TYP.)

# ELEVATION – CABINETS

SCALE 1: 50

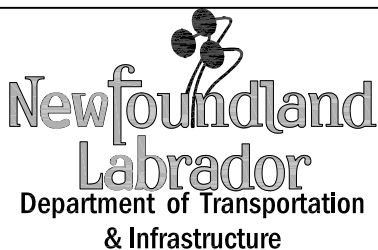
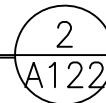

project  
SCHOOL PLANNING MANUAL

title  
PLAN & ELEVATION  
ELEMENTARY 4 to 6 CLASSROOM

date  
2022/12/16

drawing no.  
A122  
Rev. 2



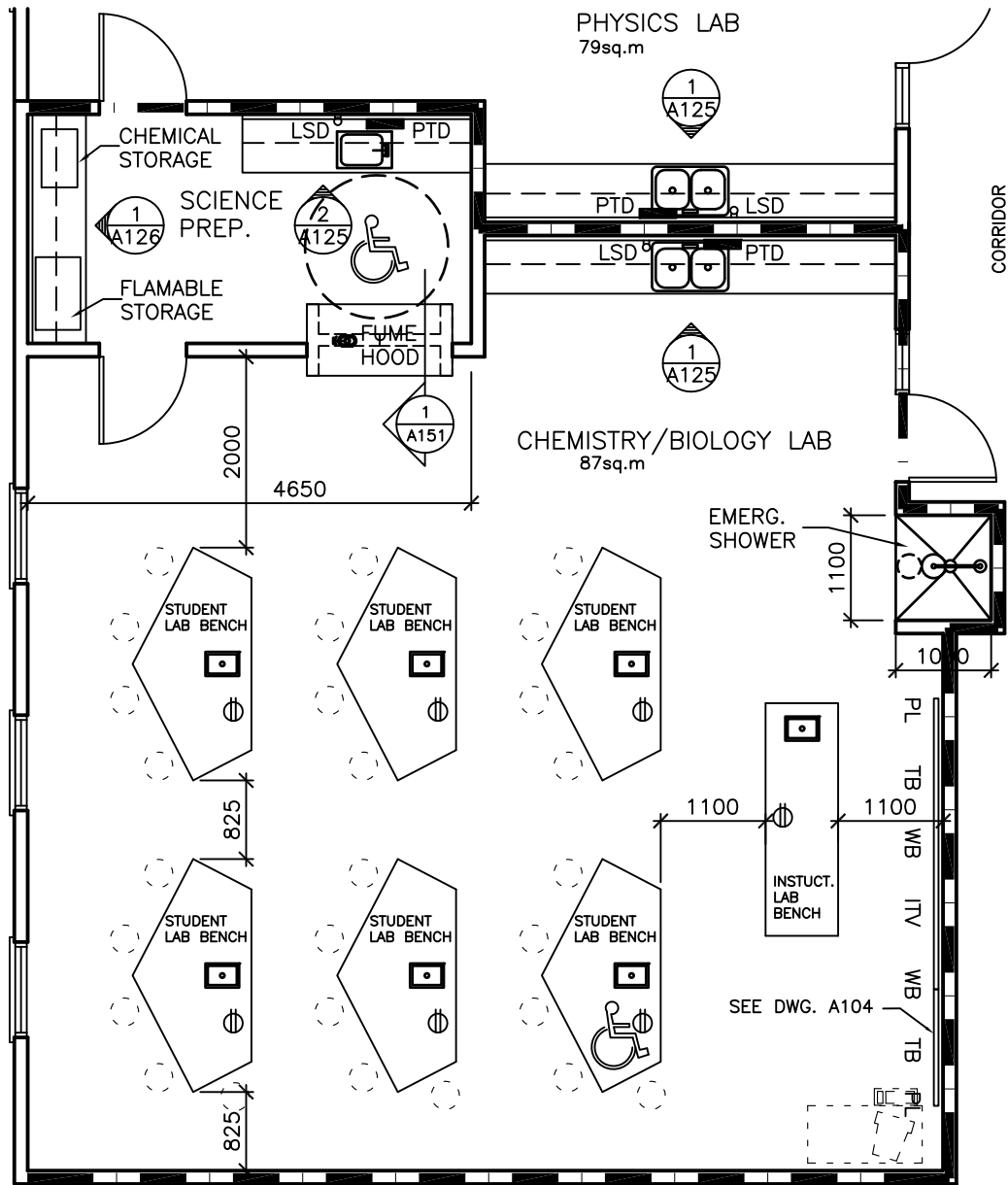

— | — FIRE SEPARATION

## PLAN-LAYOUT

SCALE 1: 75

1  
A124

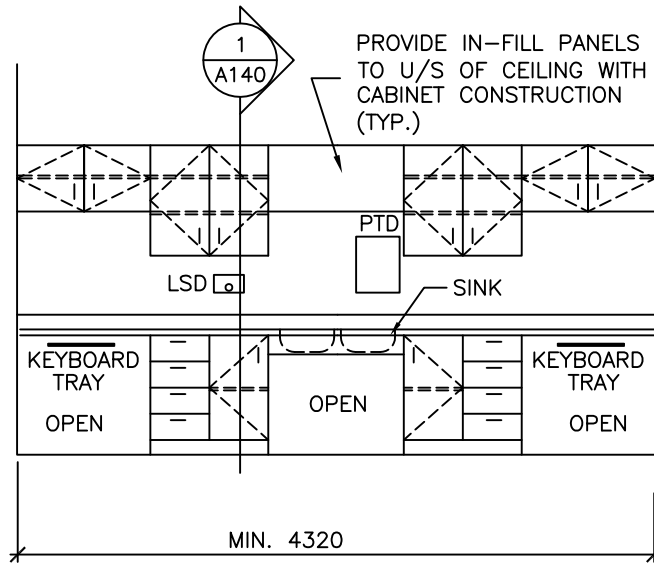

ALL CABINET DOOR AND DRAWERS  
TO HAVE LOCKS (TYP.)

### ELEVATION – CABINET

SCALE 1: 50

1  
A125

ALL CABINET DOOR AND DRAWERS  
TO HAVE LOCKS (TYP.)

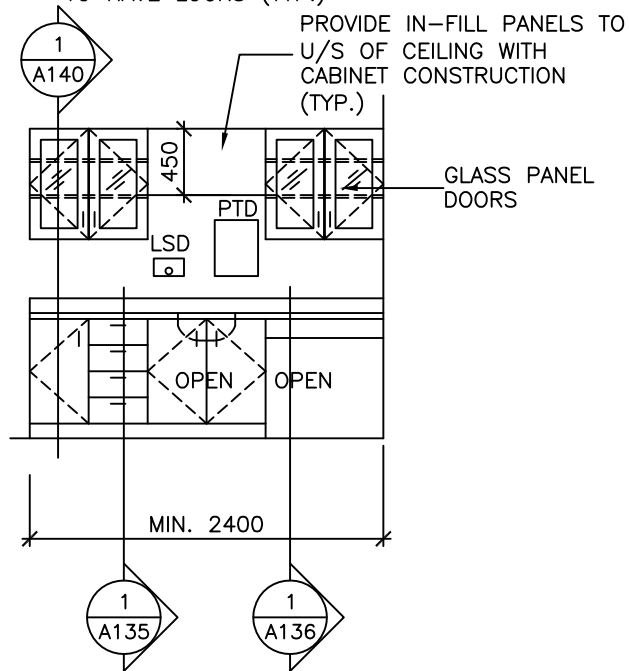

### ELEVATION – CABINET

SCALE 1: 50

2  
A125

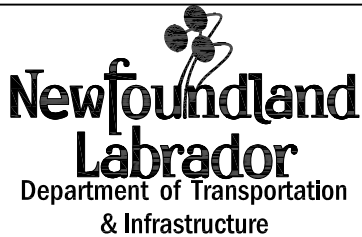

project  
SCHOOL PLANNING MANUAL

date  
2022/12/16

title  
ELEV. – SCIENCE LAB  
AND PREPARATION

drawing no.  
A125  
Rev. 0

ALL CABINET DOORS TO HAVE LOCKS (TYP.)

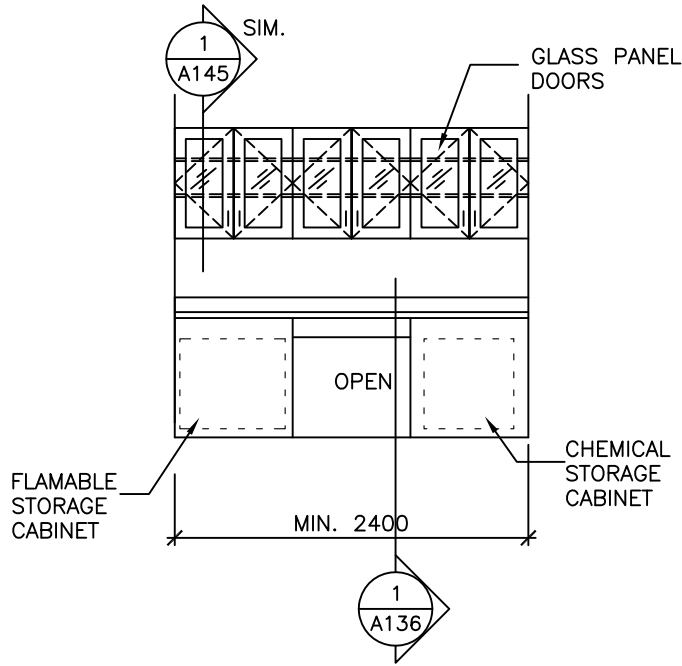

ELEVATION—CABINET

SCALE 1: 50

1  
A126

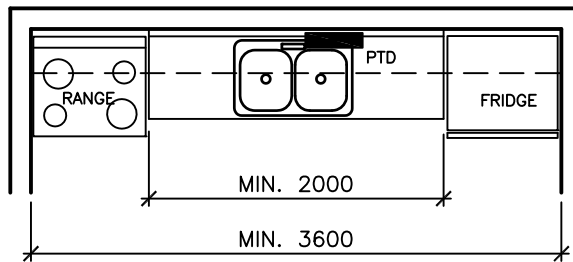

2  
A127

PLAN-LAYOUT

1  
A127

SCALE 1: 50

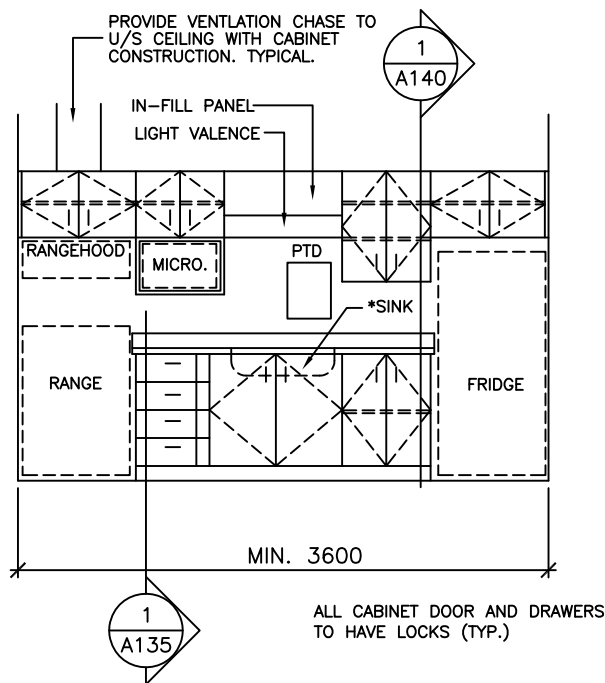

ELEVATION - CABINETS

2  
A127

SCALE 1 : 50

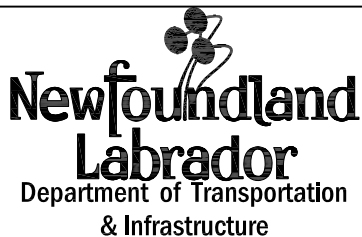

project  
SCHOOL PLANNING MANUAL

date  
2022/12/16

title  
PLAN & ELEVATION  
STAFF/TEACHER PREPARATION

drawing no.  
A127  
Rev. 0

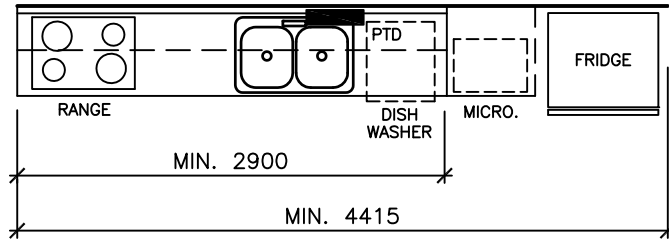

2  
A128

PLAN-LAYOUT

1  
A128

SCALE 1: 50

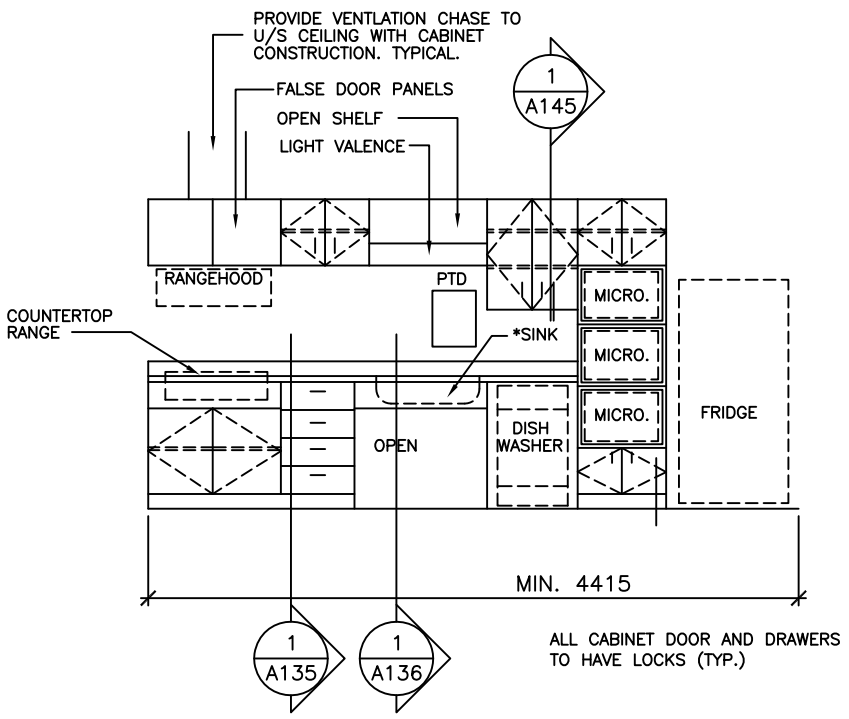

ELEVATION - CABINETS

2  
A128

SCALE 1 : 50

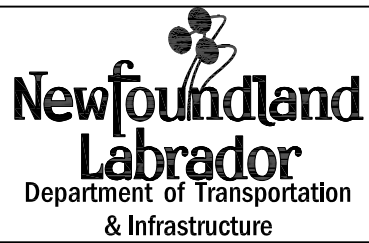

project  
SCHOOL PLANNING MANUAL

title  
PLAN & ELEVATION  
STAFF/TEACHER PREPARATION

date  
2022/12/16

drawing no.  
A128  
Rev. 3



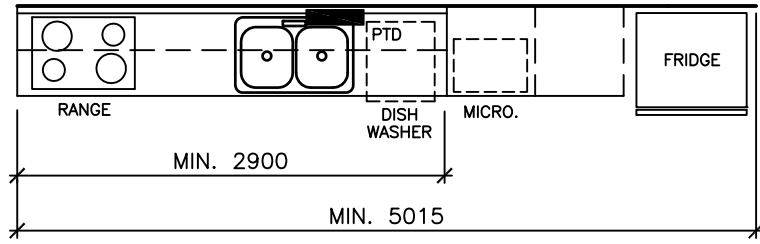

2  
A129

**PLAN-LAYOUT**

1  
A129

SCALE 1: 50

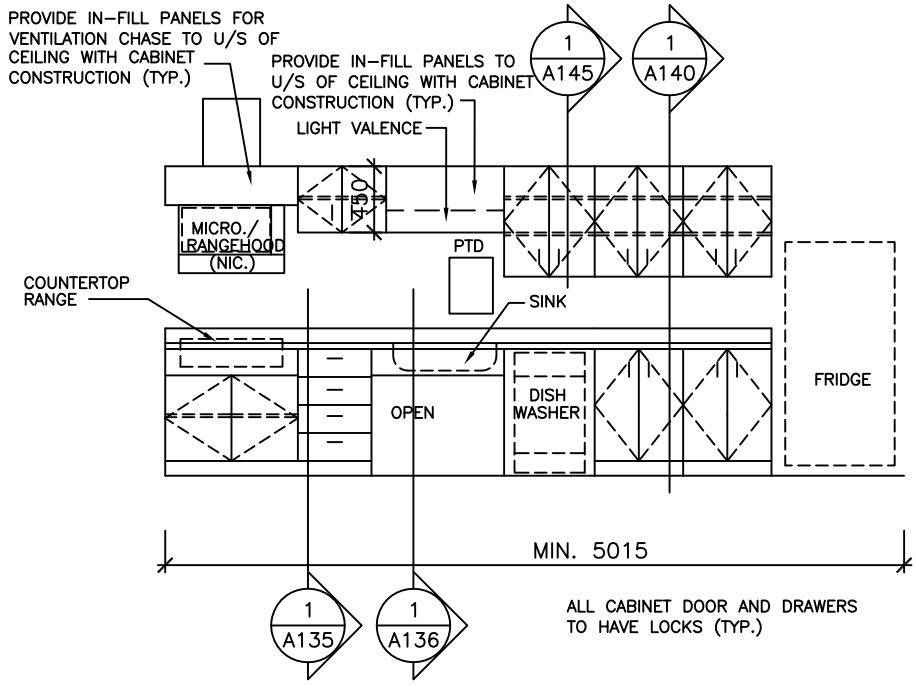

**ELEVATION - CABINETS**

2  
A129

SCALE 1 : 50

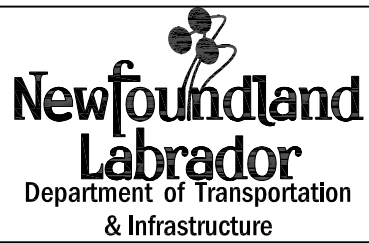

project	SCHOOL PLANNING MANUAL
title	PLAN & ELEVATION STAFF/TEACHER PREPARATION

date	2022/12/16
drawing no.	A129 Rev. 3

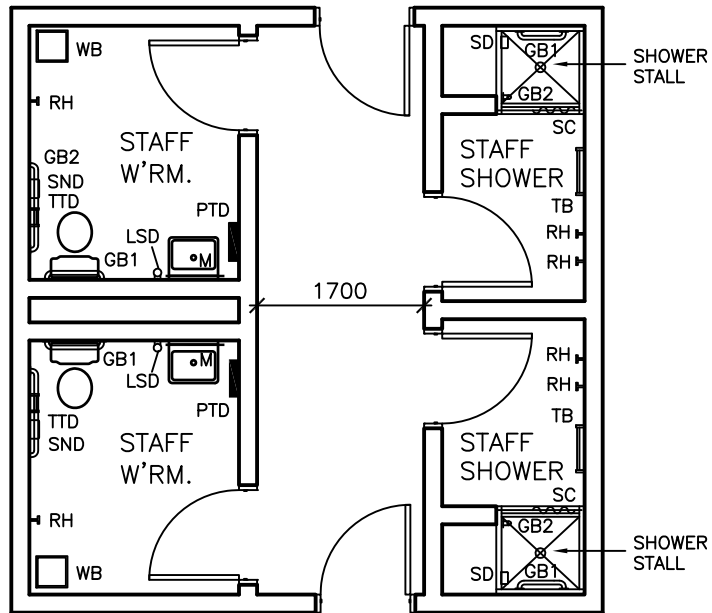

PLAN-LAYOUT

SCALE 1: 75

1  
A130

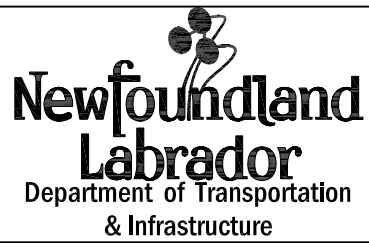

project	SCHOOL PLANNING MANUAL
title	PLAN-WASHROOM/SHOWER STAFF/TEACHER PREPARATION

date	2022/12/16
drawing no.	A130 Rev. 0



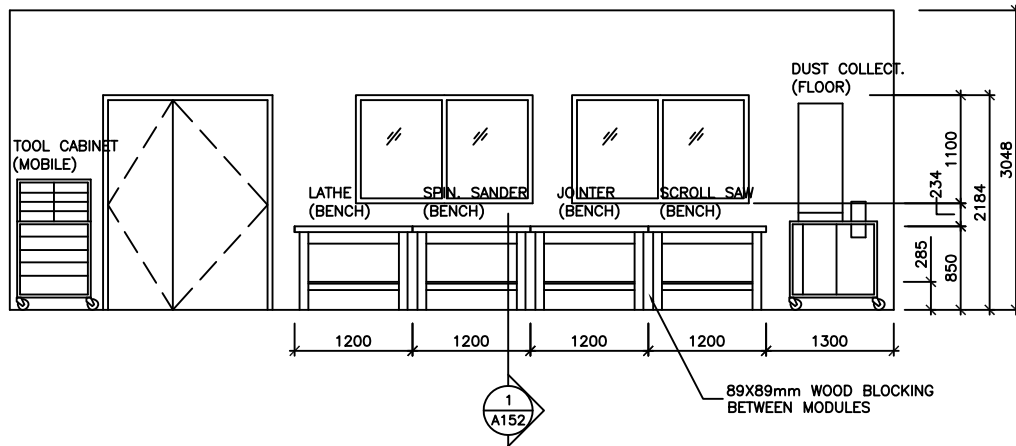

### ELEVATION 'A'

1  
A132

SCALE 1: 75

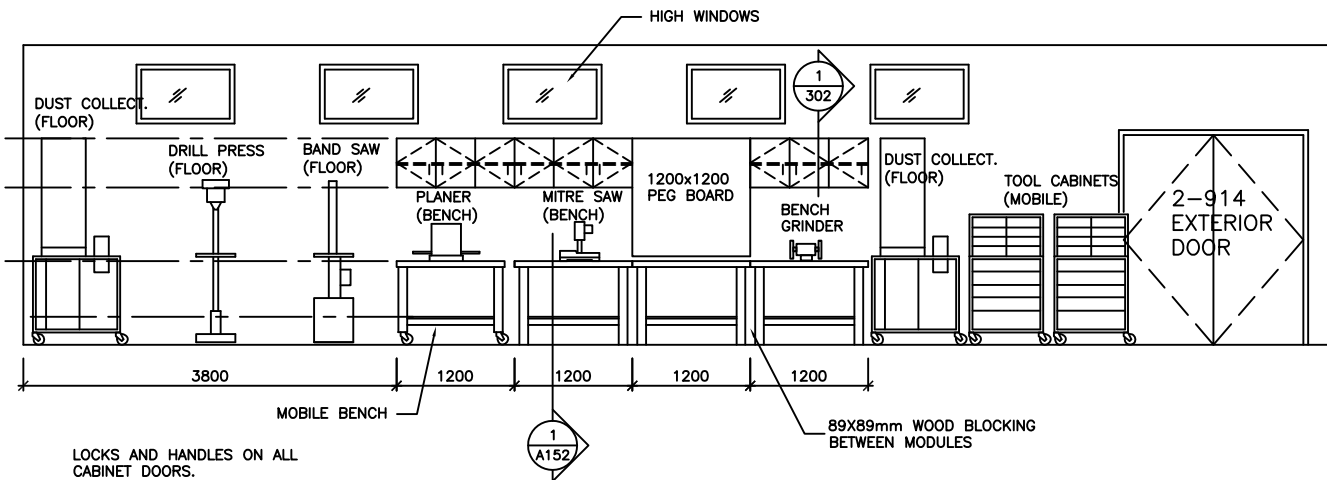

### ELEVATION 'B'

2  
A132

SCALE 1: 75

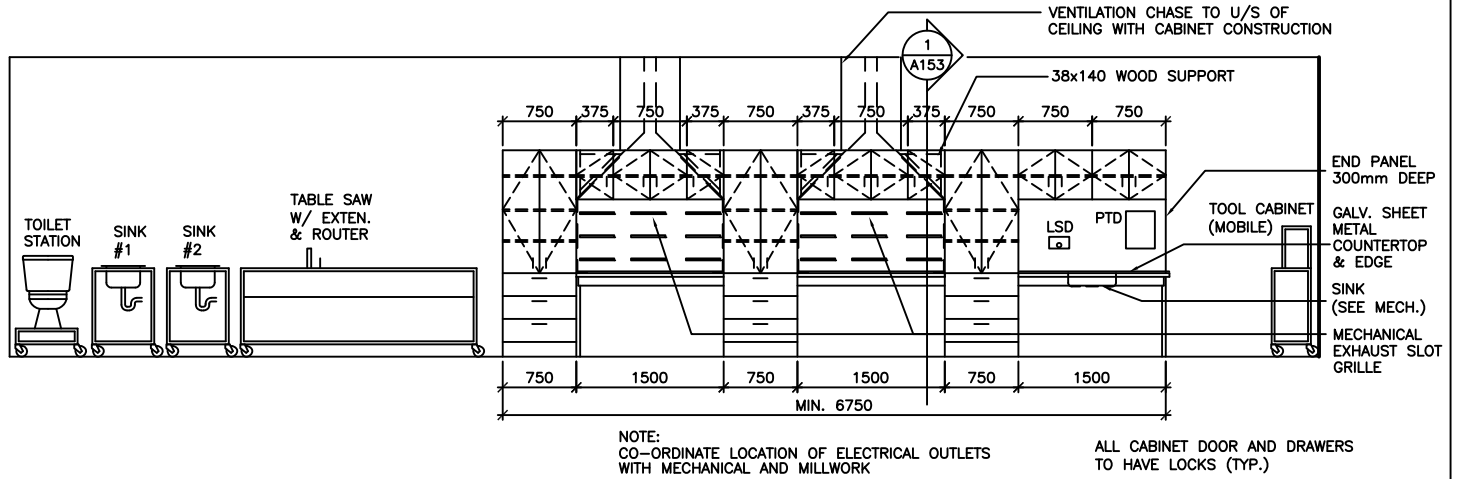

**ELEVATION 'C'** 1  
A133

SCALE 1: 75

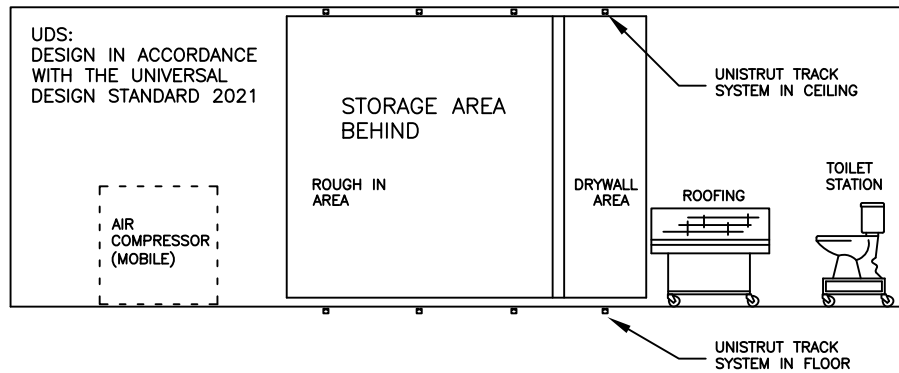

**ELEVATION 'D'** 2  
A133



project  
SCHOOL PLANNING MANUAL

title  
ELEVATION –  
SKILLED TRADES

date  
2022/12/16

drawing no.  
A133  
Rev. 3

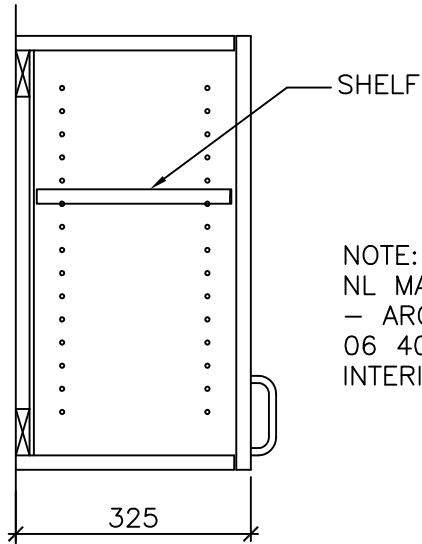

NOTE: MILLWORK DESIGN TO FOLLOW  
 NL MASTER SPEC SECTIONS 06 40 00  
 – ARCHITECTURAL WOODWORK, AND  
 06 40 23.13 – PLASTIC LAMINATE FOR  
 INTERIOR ARCHITECTURAL WOODWORK

## SECTION – CABINET

SCALE 1 : 10

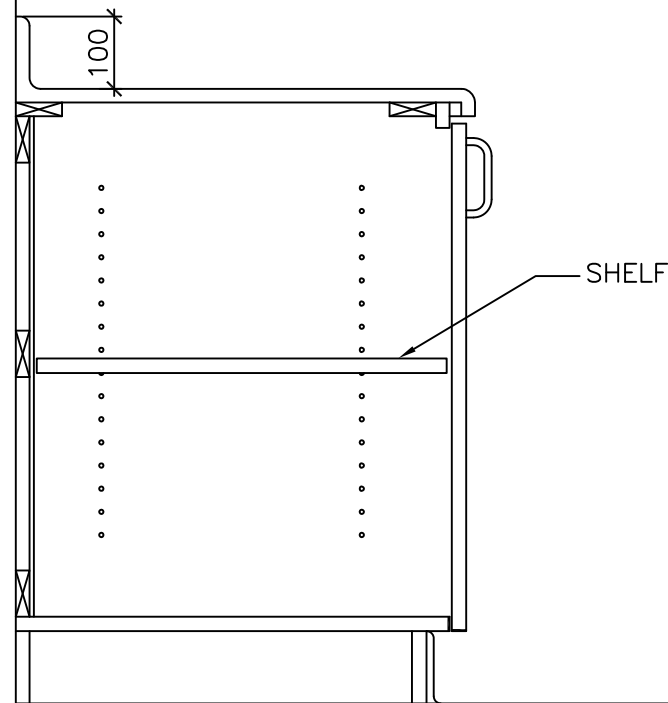

NOTE: MILLWORK DESIGN TO FOLLOW  
 NL MASTER SPEC SECTIONS 06 40 00  
 – ARCHITECTURAL WOODWORK, AND  
 06 40 23.13 – PLASTIC LAMINATE FOR  
 INTERIOR ARCHITECTURAL WOODWORK

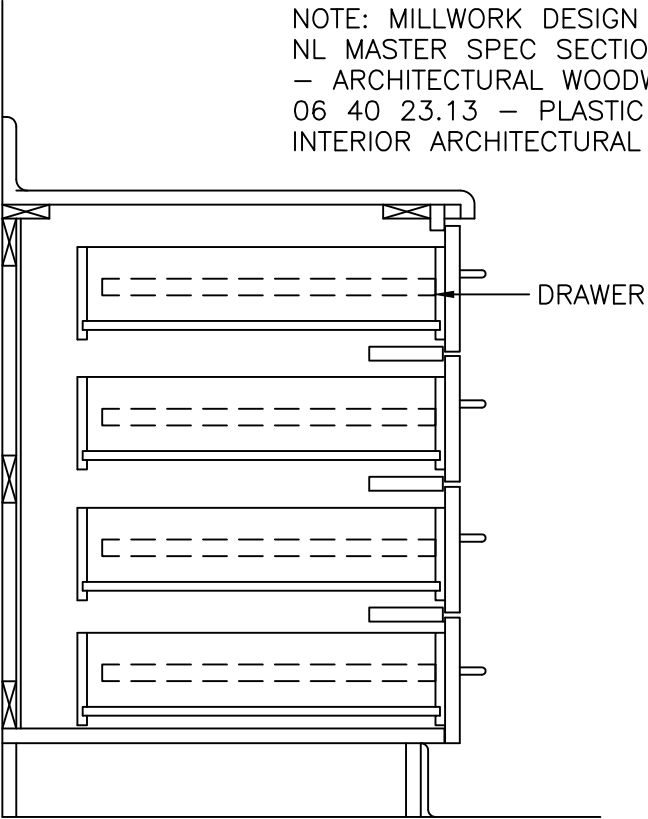

**SECTION – CABINETS**

SCALE 1 : 10

	project SCHOOL PLANNING MANUAL	date 2022/12/16
	title SECTION – MILLWORK	drawing no. A135 Rev. 0

NOTE: MILLWORK DESIGN TO FOLLOW  
 NL MASTER SPEC SECTIONS 06 40 00  
 – ARCHITECTURAL WOODWORK, AND  
 06 40 23.13 – PLASTIC LAMINATE FOR  
 INTERIOR ARCHITECTURAL WOODWORK

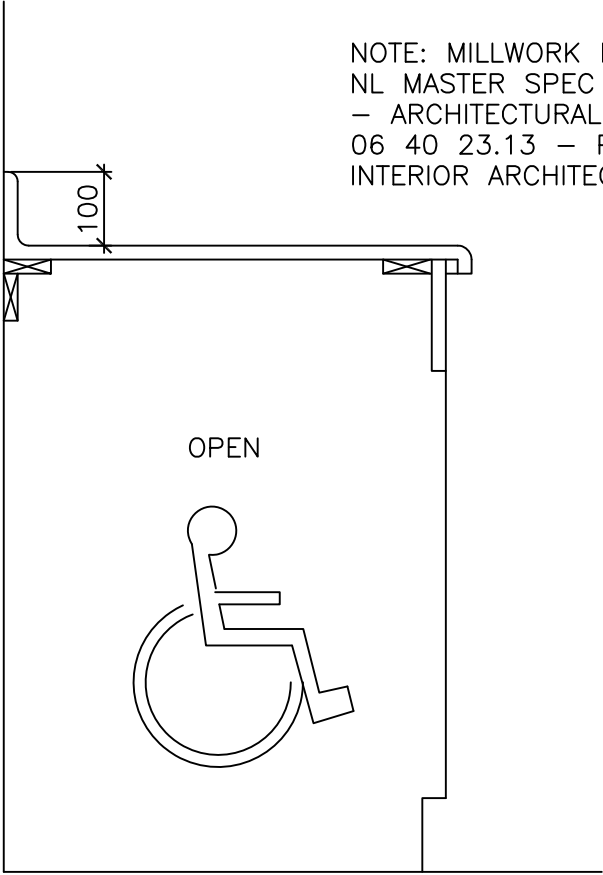

**SECTION – CABINETS**

SCALE 1 : 10

	<b>project</b> SCHOOL PLANNING MANUAL	<b>date</b> 2022/12/16
	<b>title</b> SECTION – MILLWORK	<b>drawing no.</b> A136 Rev. 1



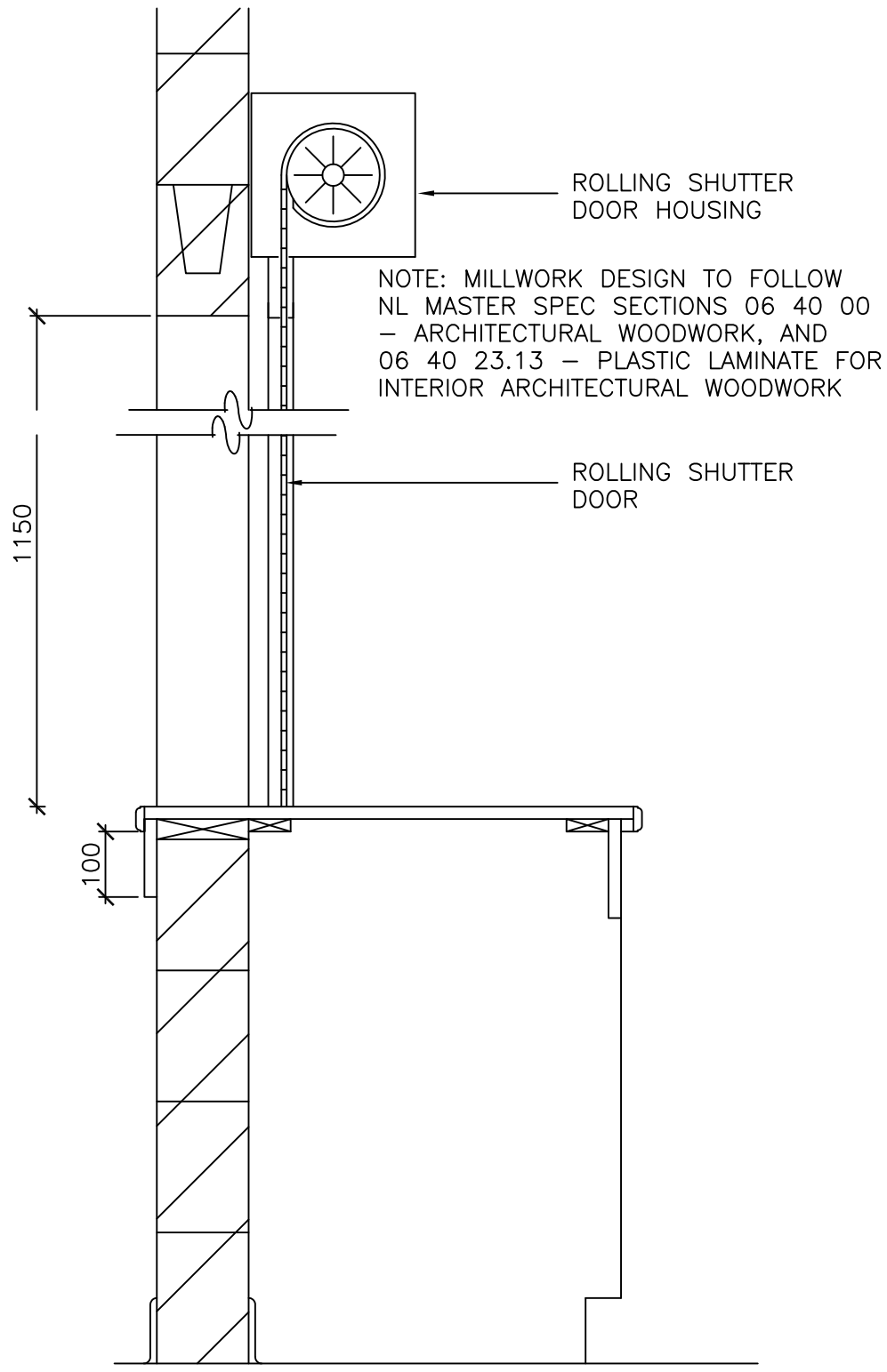

## SECTION – CABINETS

SCALE 1 : 10

NOTE: MILLWORK DESIGN TO FOLLOW  
 NL MASTER SPEC SECTIONS 06 40 00  
 – ARCHITECTURAL WOODWORK, AND  
 06 40 23.13 – PLASTIC LAMINATE FOR  
 INTERIOR ARCHITECTURAL WOODWORK

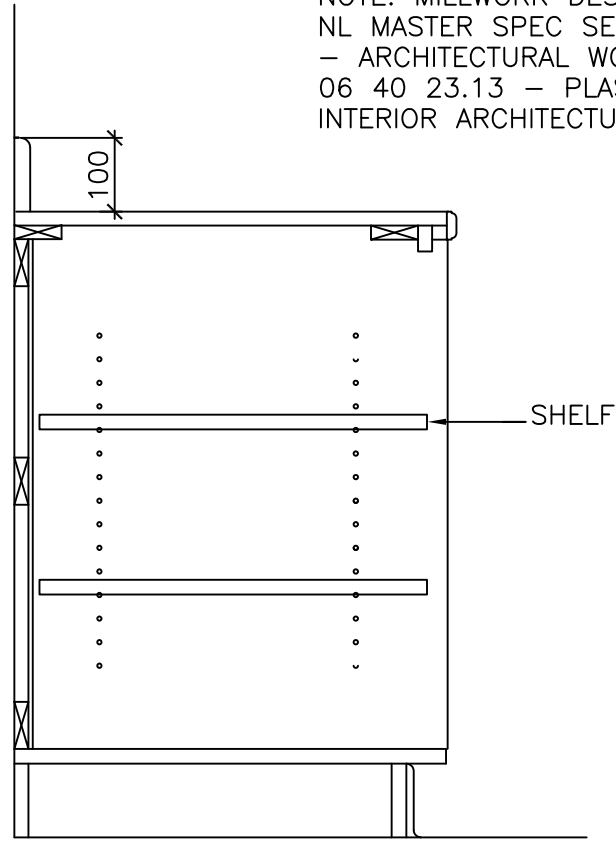

## SECTION – CABINETS

SCALE 1 : 10

NOTE: MILLWORK DESIGN TO FOLLOW  
 NL MASTER SPEC SECTIONS 06 40 00  
 – ARCHITECTURAL WOODWORK, AND  
 06 40 23.13 – PLASTIC LAMINATE FOR  
 INTERIOR ARCHITECTURAL WOODWORK

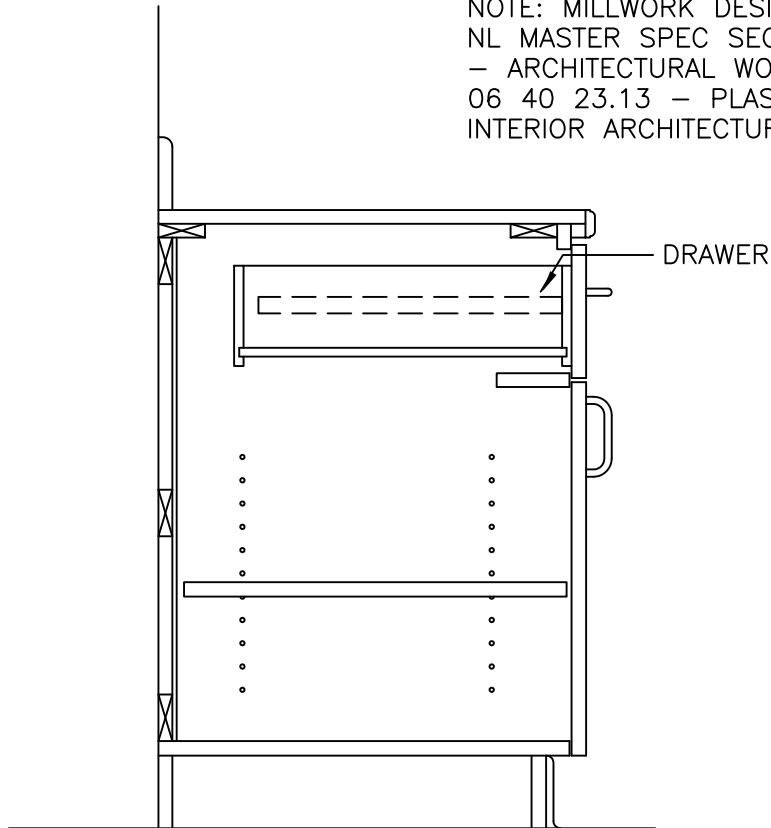

## SECTION – CABINETS

SCALE 1 : 10

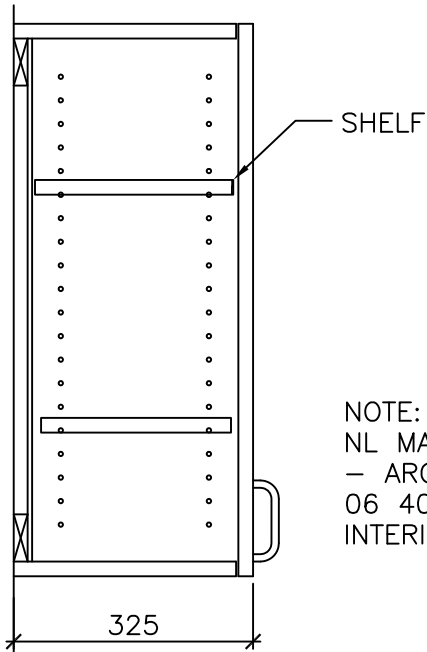

NOTE: MILLWORK DESIGN TO FOLLOW  
 NL MASTER SPEC SECTIONS 06 40 00  
 – ARCHITECTURAL WOODWORK, AND  
 06 40 23.13 – PLASTIC LAMINATE FOR  
 INTERIOR ARCHITECTURAL WOODWORK

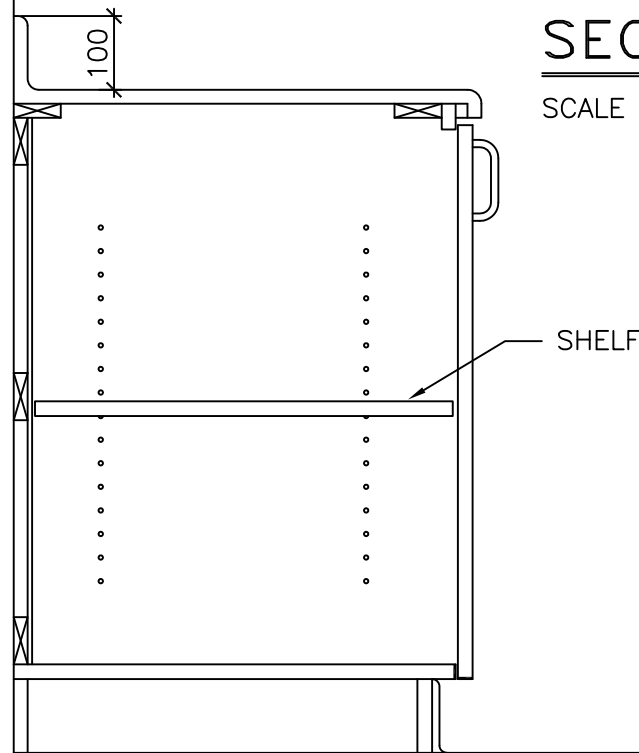

## SECTION – CABINET

SCALE 1 : 10

 <p><b>Newfoundland Labrador</b> Department of Transportation &amp; Infrastructure</p>	<p>project SCHOOL PLANNING MANUAL</p>	<p>date 2022/12/16</p>
	<p>title SECTION – MILLWORK</p>	<p>drawing no. A140 Rev. 0</p>

NOTE: MILLWORK DESIGN TO FOLLOW  
 NL MASTER SPEC SECTIONS 06 40 00  
 – ARCHITECTURAL WOODWORK, AND  
 06 40 23.13 – PLASTIC LAMINATE FOR  
 INTERIOR ARCHITECTURAL WOODWORK

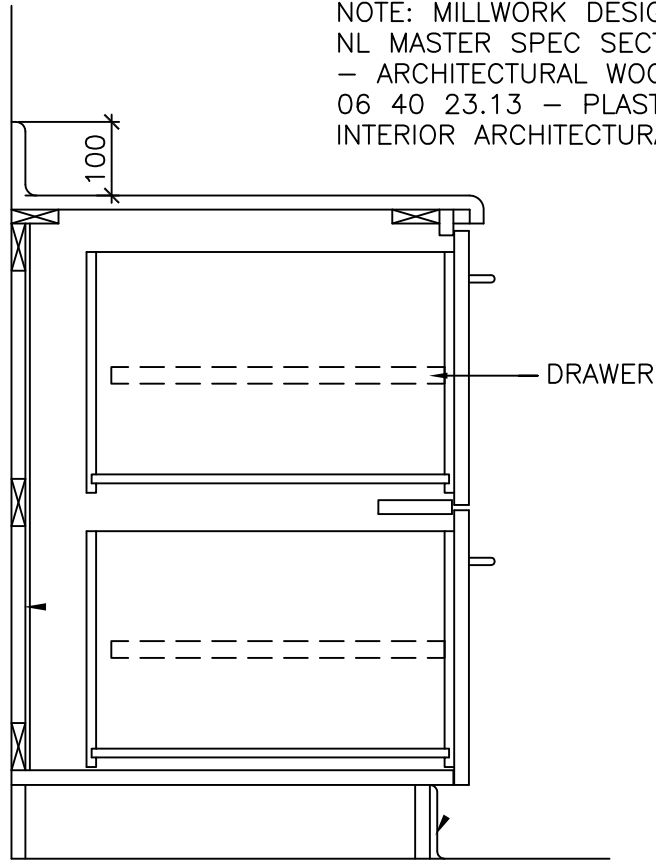

## SECTION – CABINETS

SCALE 1 : 10

	project SCHOOL PLANNING MANUAL	date 2022/12/16
	title SECTION – MILLWORK	drawing no. A141 Rev. 0

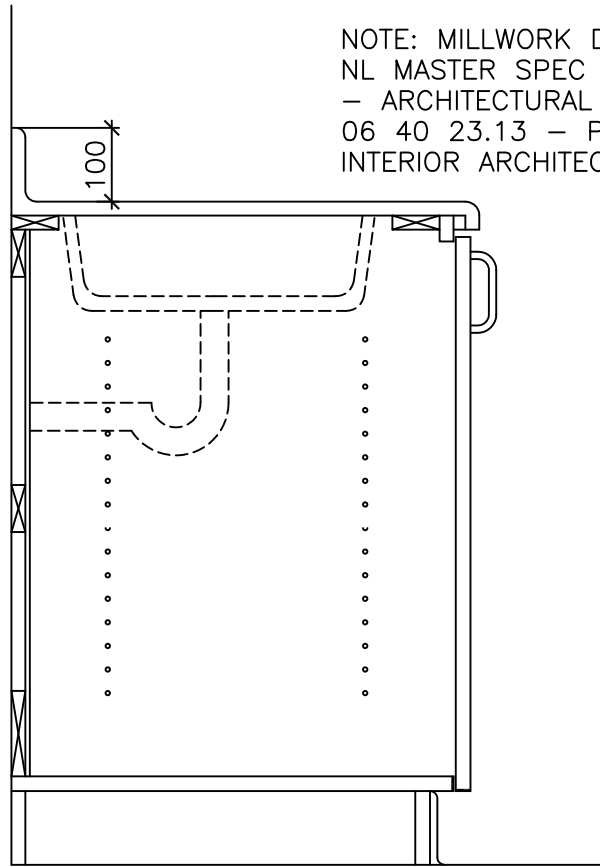

NOTE: MILLWORK DESIGN TO FOLLOW  
 NL MASTER SPEC SECTIONS 06 40 00  
 – ARCHITECTURAL WOODWORK, AND  
 06 40 23.13 – PLASTIC LAMINATE FOR  
 INTERIOR ARCHITECTURAL WOODWORK

## SECTION – CABINETS

SCALE 1 : 10

	<b>project</b> SCHOOL PLANNING MANUAL	<b>date</b> 2022/12/16
	<b>title</b> SECTION – MILLWORK	<b>drawing no.</b> A142 Rev. 0

NOTE: MILLWORK DESIGN TO FOLLOW  
 NL MASTER SPEC SECTIONS 06 40 00  
 – ARCHITECTURAL WOODWORK, AND  
 06 40 23.13 – PLASTIC LAMINATE FOR  
 INTERIOR ARCHITECTURAL WOODWORK

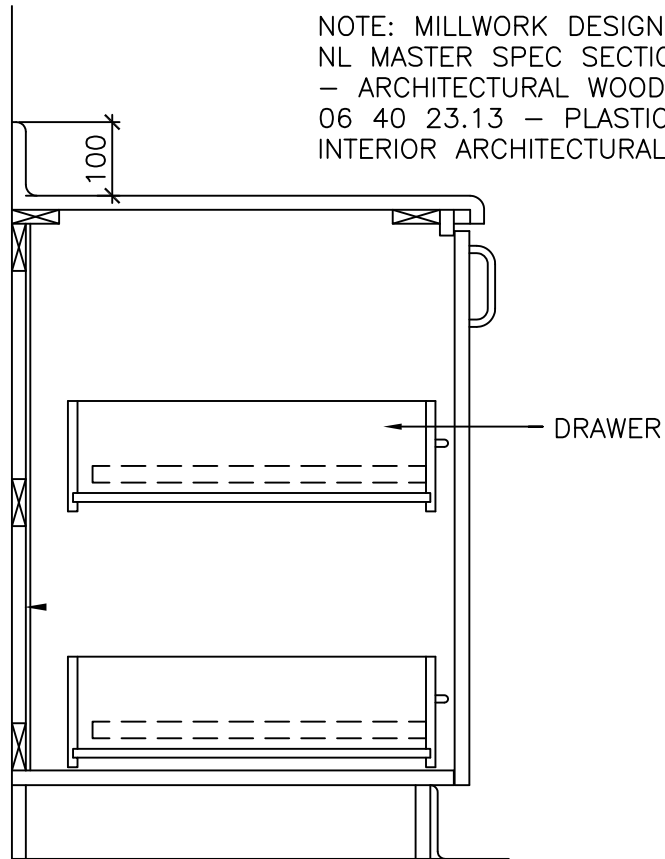

## SECTION – CABINET

SCALE 1 : 10

	project SCHOOL PLANNING MANUAL	date 2022/12/16
	title SECTION – MILLWORK	drawing no. A143 Rev. 0

NOTE: MILLWORK DESIGN TO FOLLOW  
 NL MASTER SPEC SECTIONS 06 40 00  
 - ARCHITECTURAL WOODWORK, AND  
 06 40 23.13 - PLASTIC LAMINATE FOR  
 INTERIOR ARCHITECTURAL WOODWORK

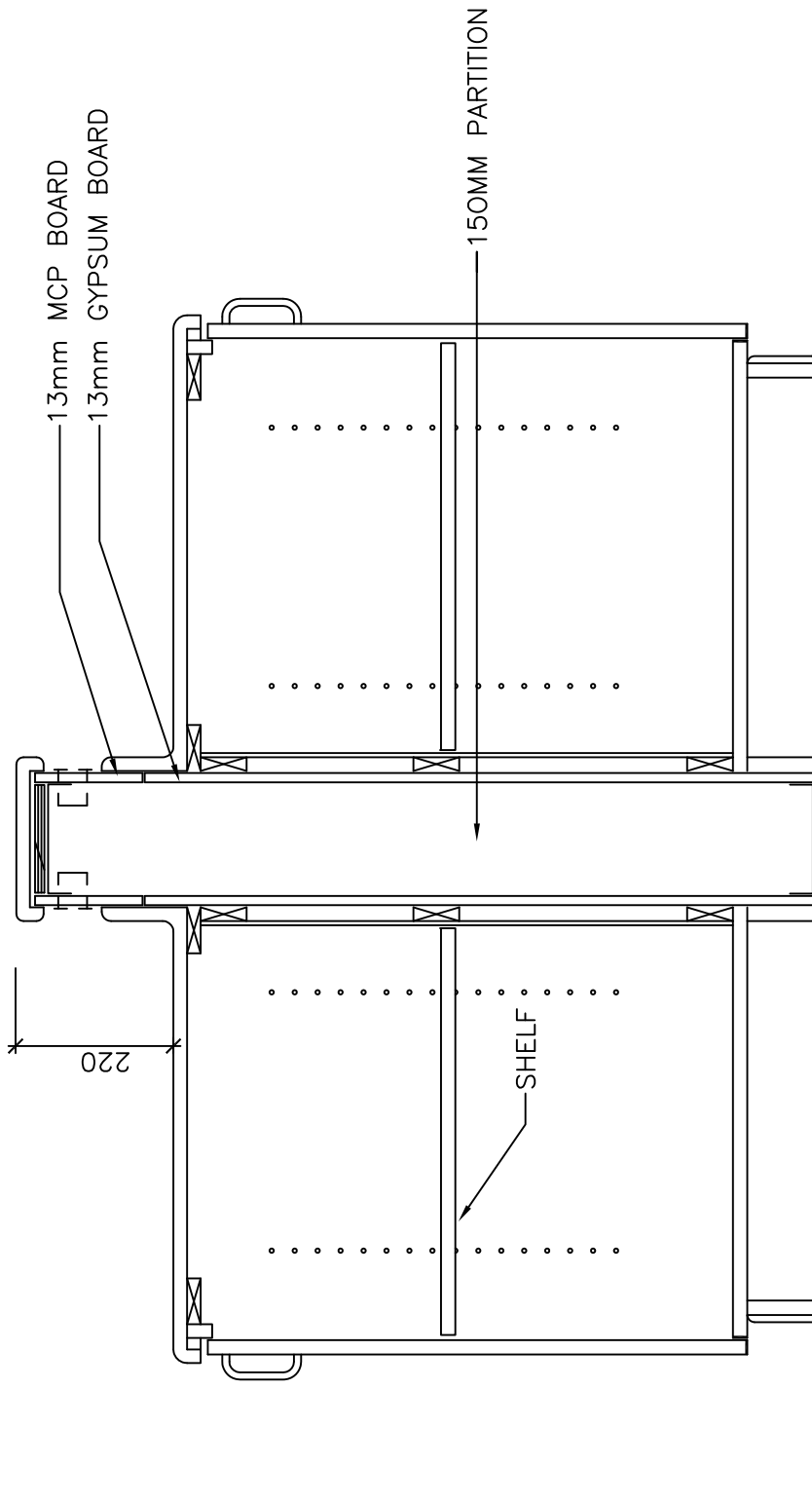

# SECTION - CABINETS

SCALE 1 : 10



NOTE: MILLWORK DESIGN TO FOLLOW  
 NL MASTER SPEC SECTIONS 06 40 00  
 – ARCHITECTURAL WOODWORK, AND  
 06 40 23.13 – PLASTIC LAMINATE FOR  
 INTERIOR ARCHITECTURAL WOODWORK

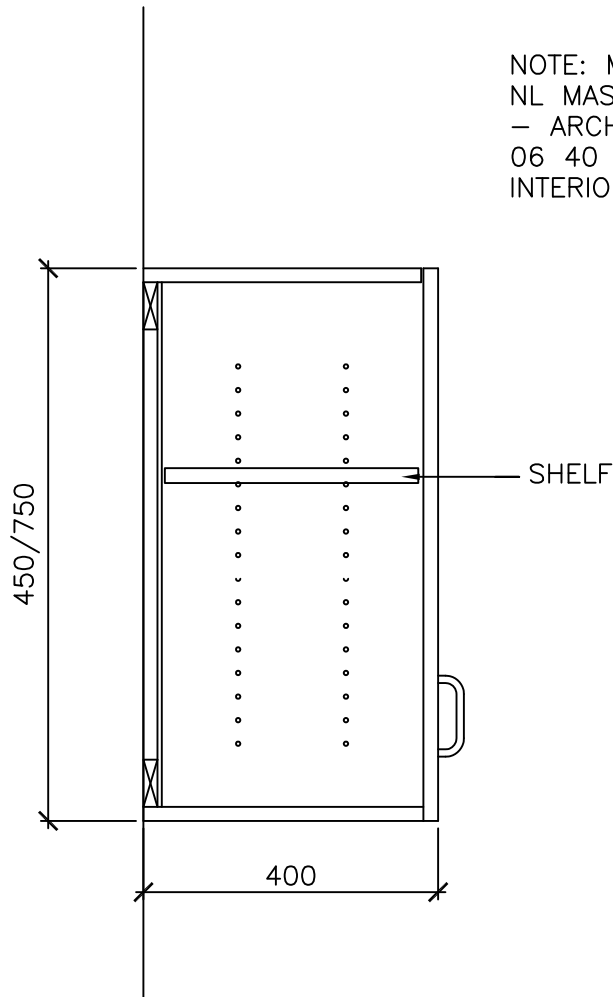

## SECTION – CABINETS

SCALE 1 : 10

NOTE: MILLWORK DESIGN TO FOLLOW  
NL MASTER SPEC SECTIONS 06 40 00  
- ARCHITECTURAL WOODWORK, AND  
06 40 23.13 - PLASTIC LAMINATE FOR  
INTERIOR ARCHITECTURAL WOODWORK

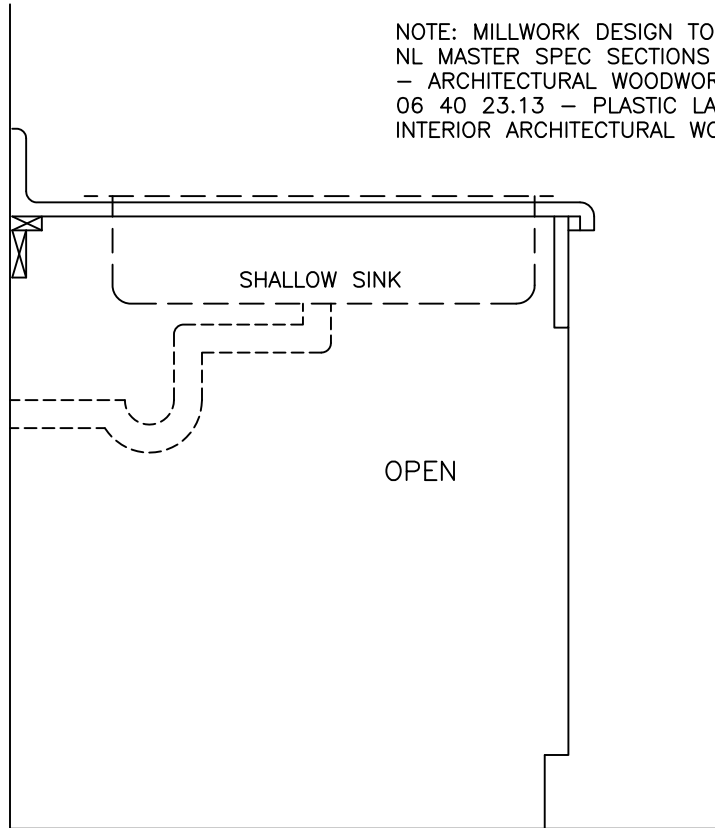

## SECTION – CABINETS

SCALE 1 : 10

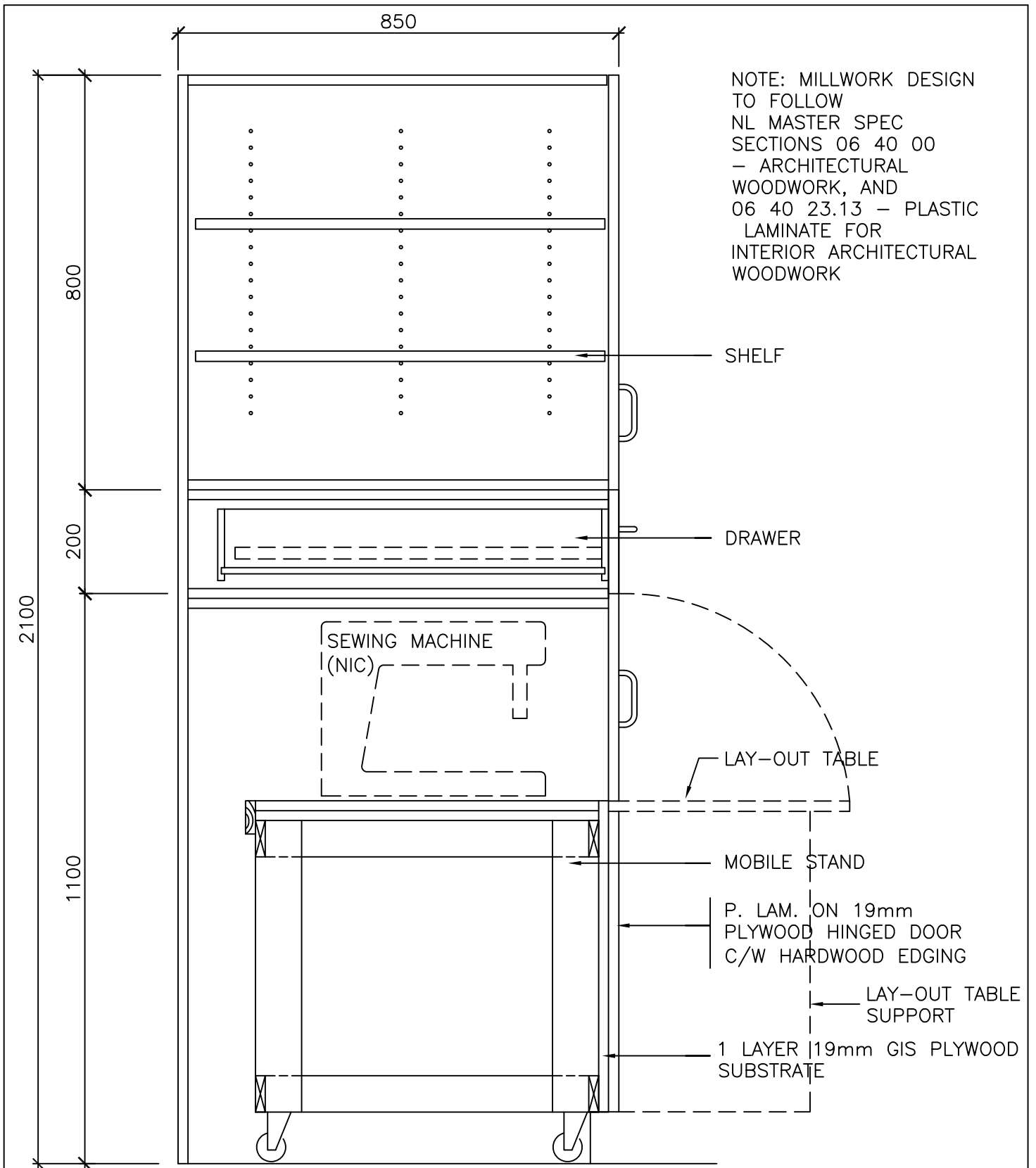

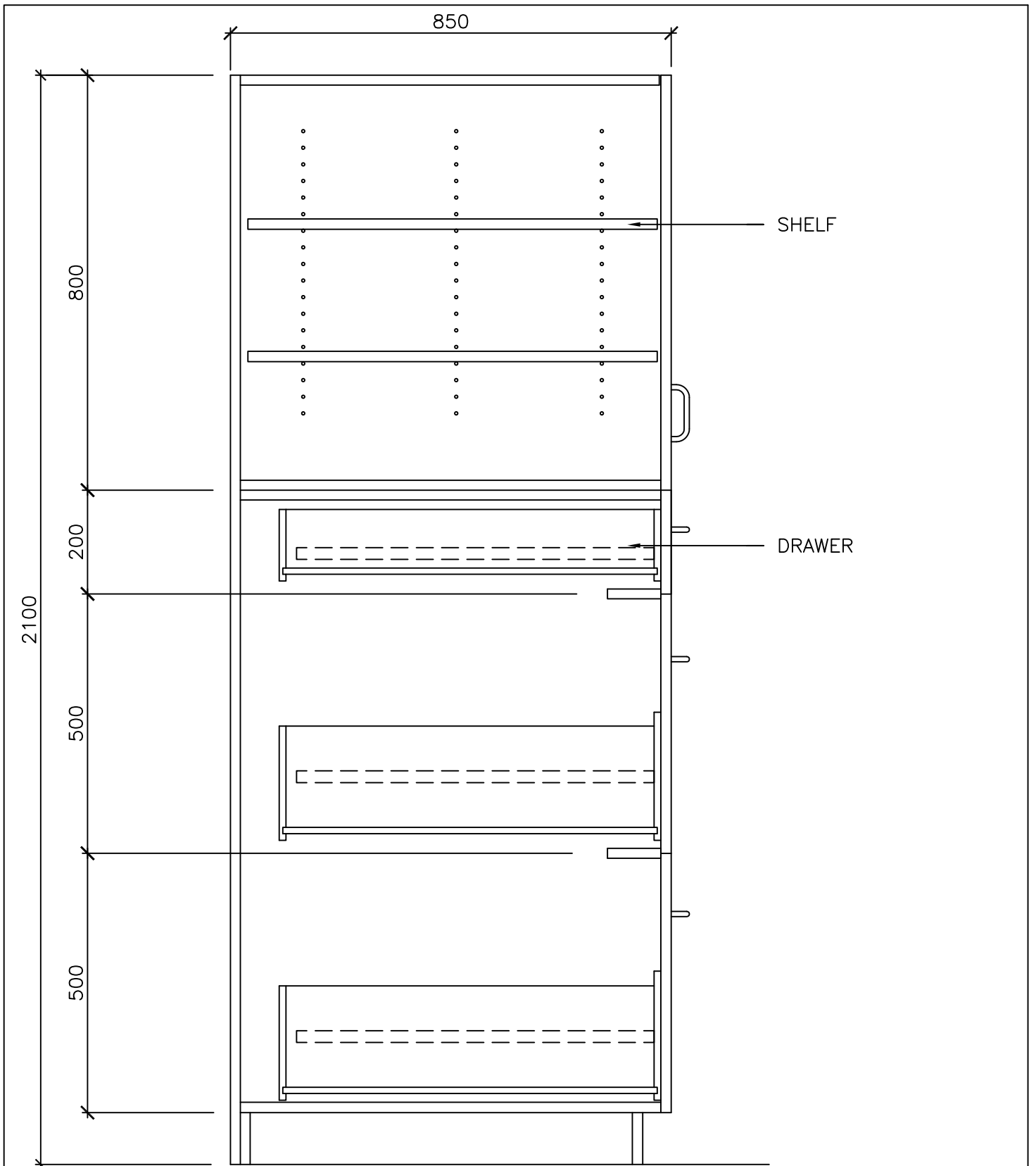

NOTE: MILLWORK DESIGN TO FOLLOW  
 NL MASTER SPEC SECTIONS 06 40 00  
 – ARCHITECTURAL WOODWORK, AND  
 06 40 23.13 – PLASTIC LAMINATE FOR  
 INTERIOR ARCHITECTURAL WOODWORK

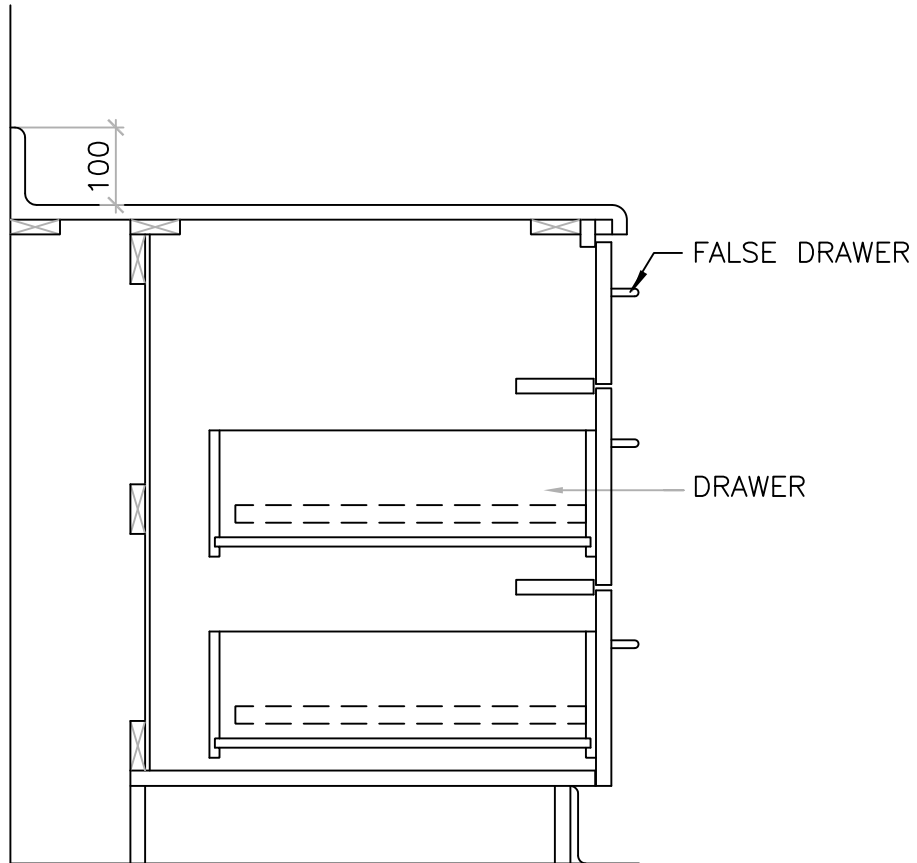

NOTE: MILLWORK DESIGN TO FOLLOW  
 NL MASTER SPEC SECTIONS 06 40 00  
 – ARCHITECTURAL WOODWORK, AND  
 06 40 23.13 – PLASTIC LAMINATE FOR  
 INTERIOR ARCHITECTURAL WOODWORK

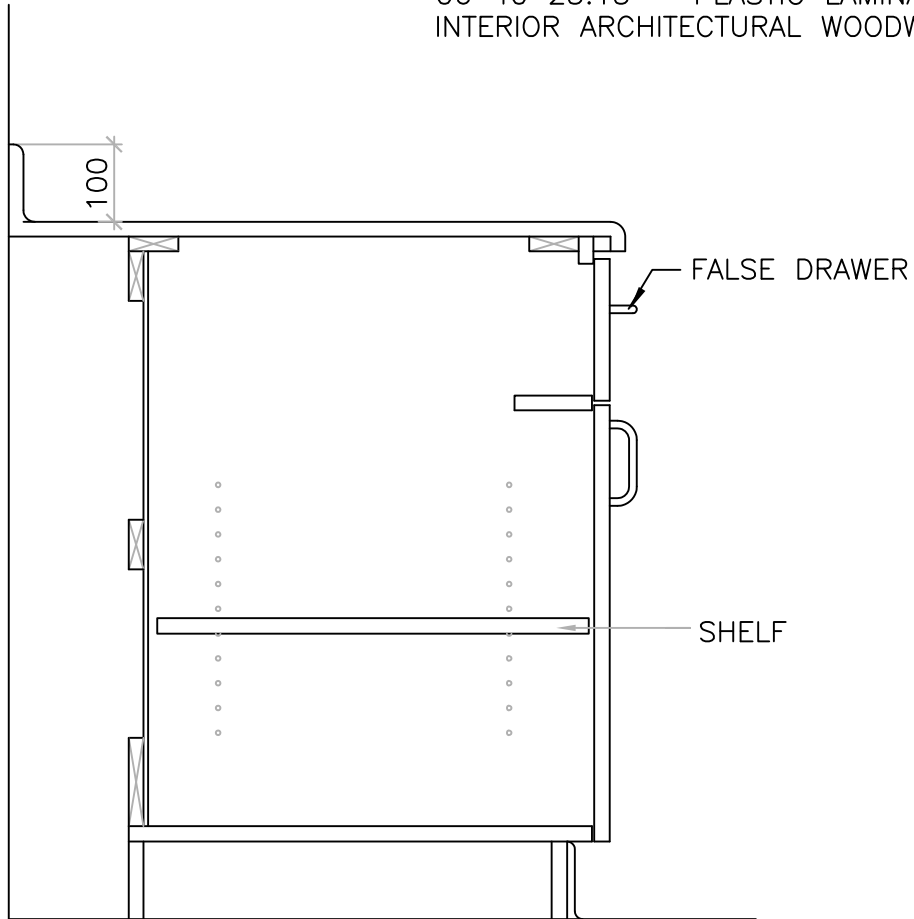

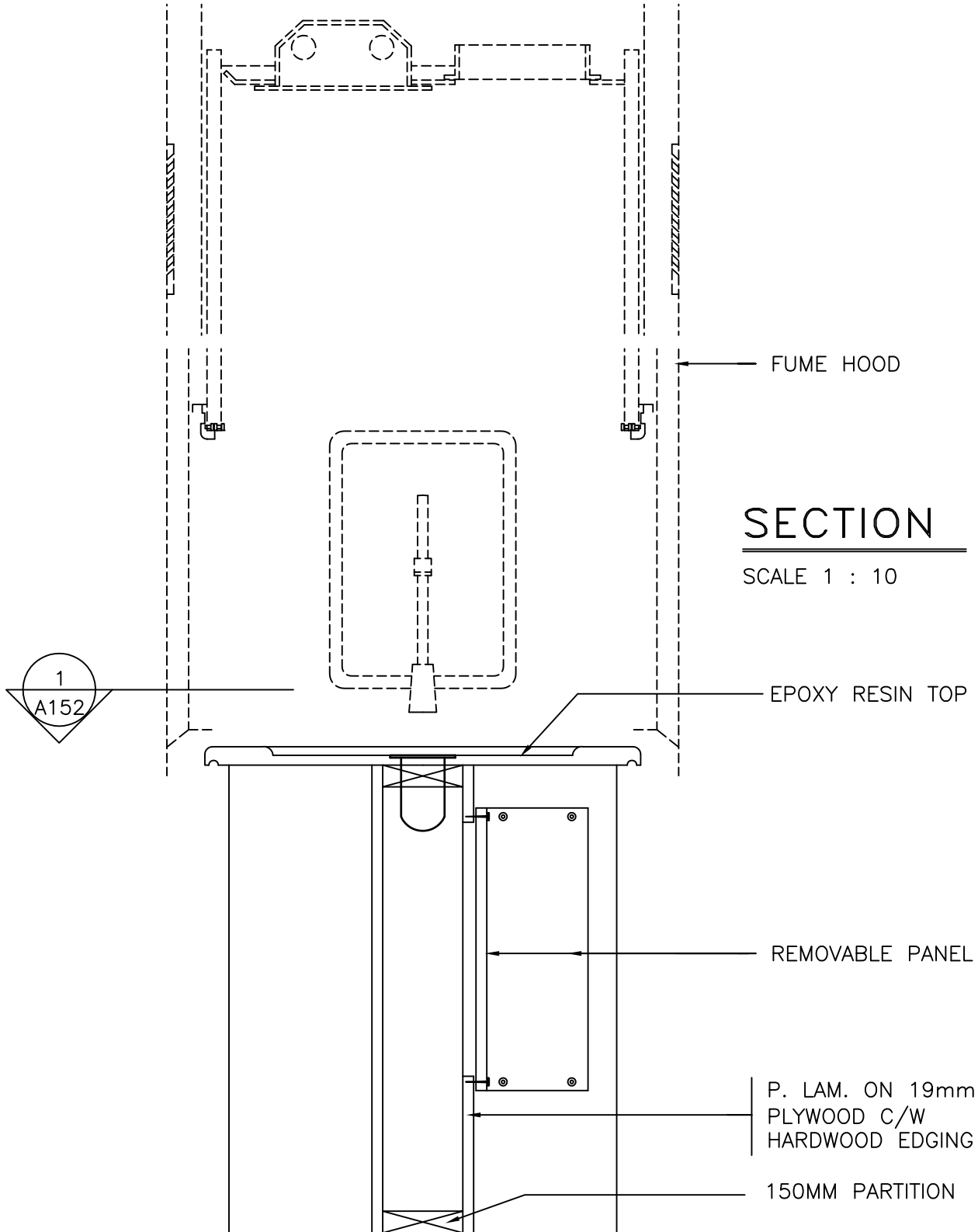

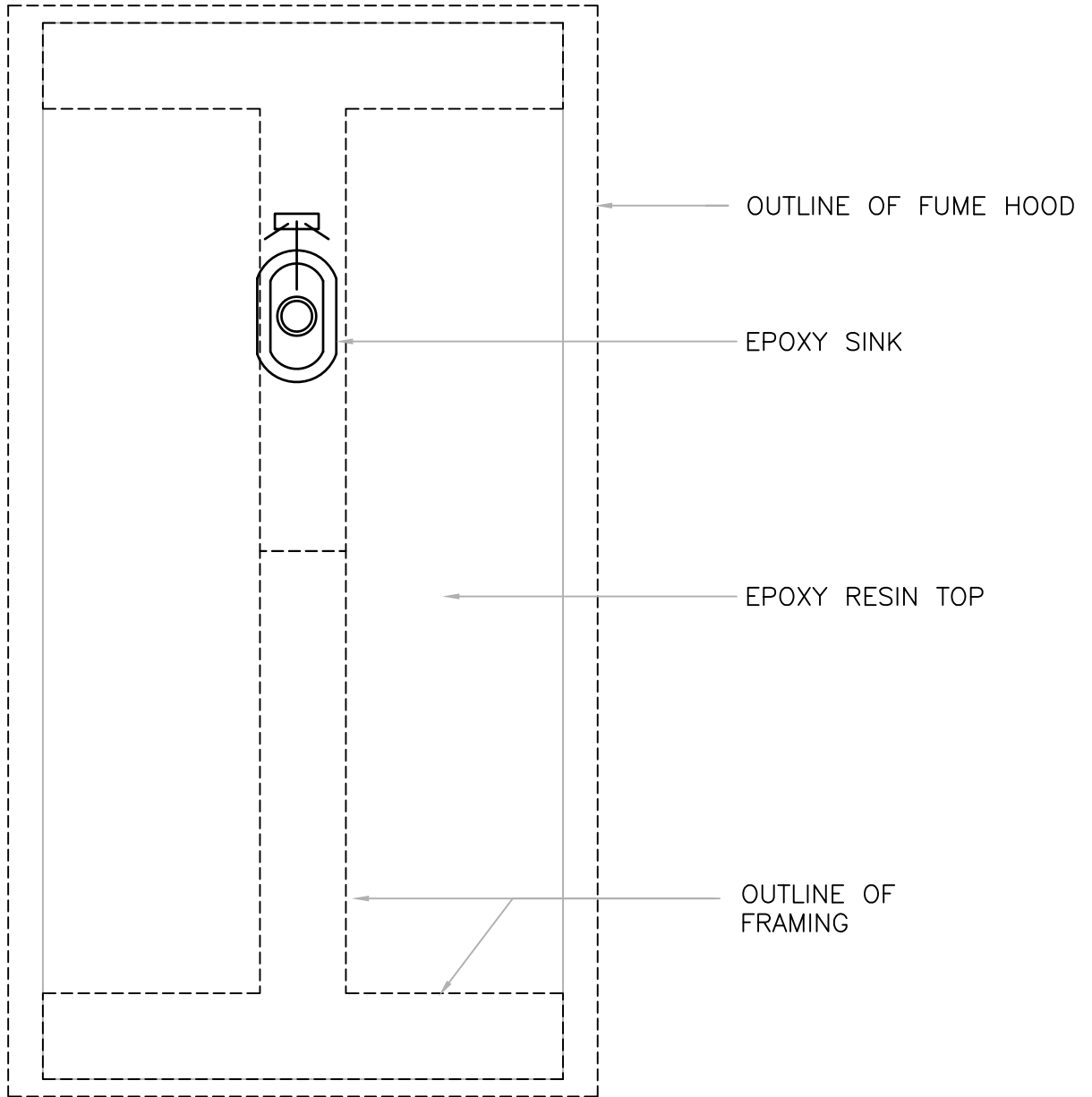

# PLAN

SCALE 1 : 10



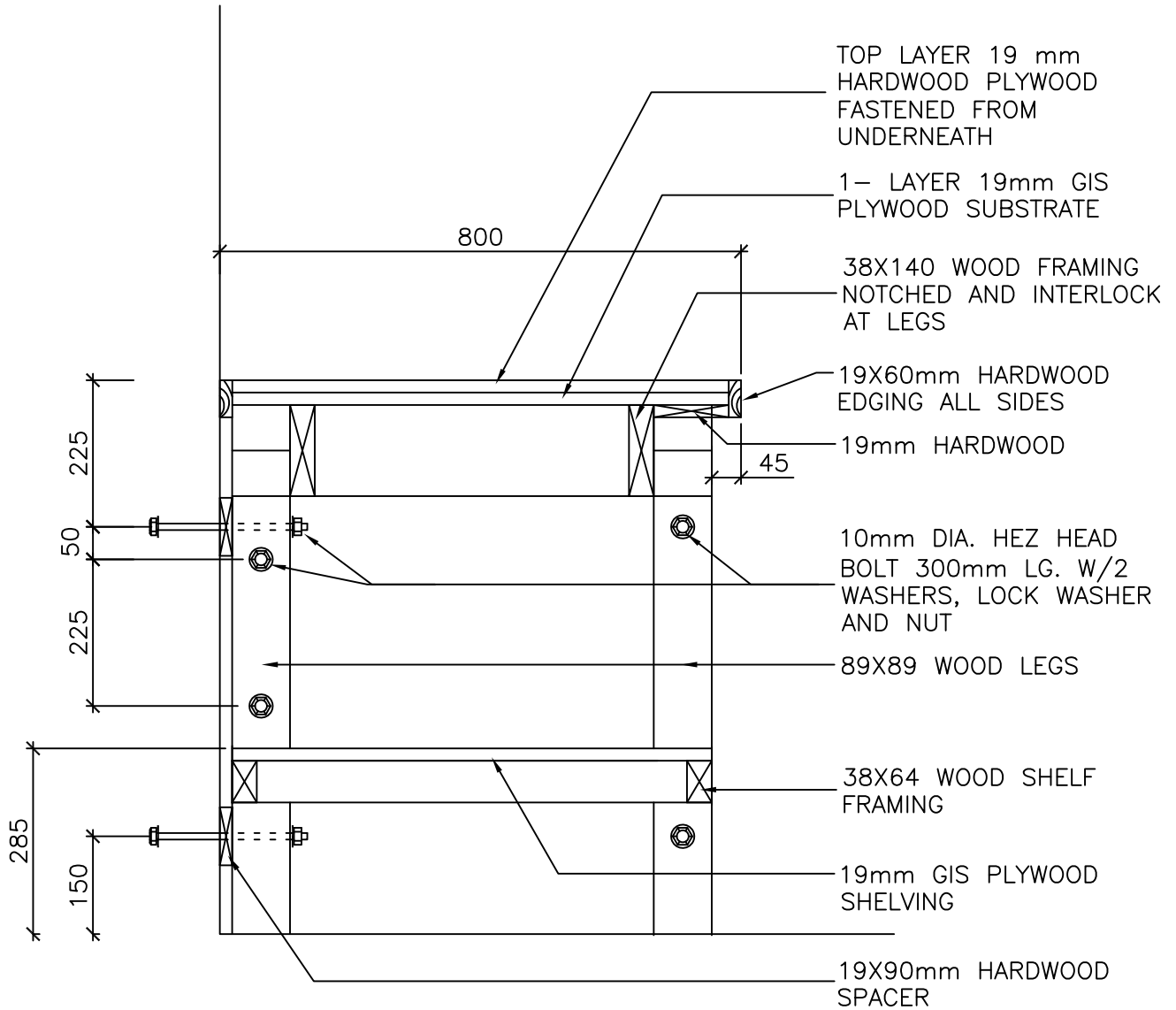

NOTE: PROVIDE BOLTS AND HOLES IN BENCHES SO THAT THEY CAN BE BOLTED TOGETHER IF REQUIRED.

## SECTION

SCALE 1 : 10

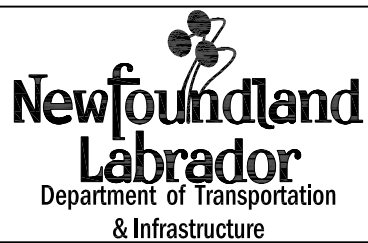

project	SCHOOL PLANNING MANUAL	date	2022/12/16
title	SECTION – MILLWORK	drawing no.	153 Rev. 1

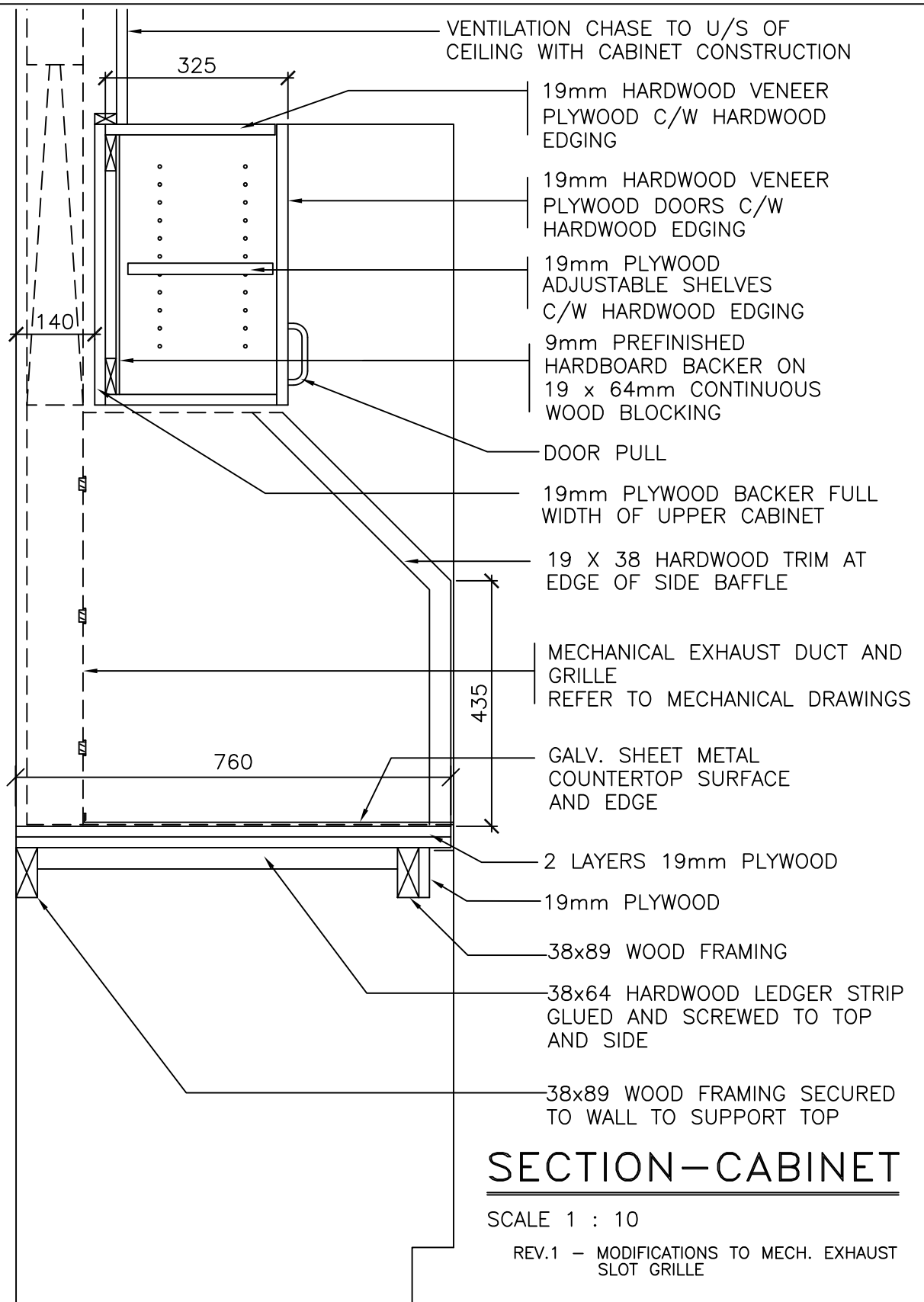

## SECTION - CABINET

SCALE 1 : 10

REV.1 - MODIFICATIONS TO MECH. EXHAUST SLOT GRILLE

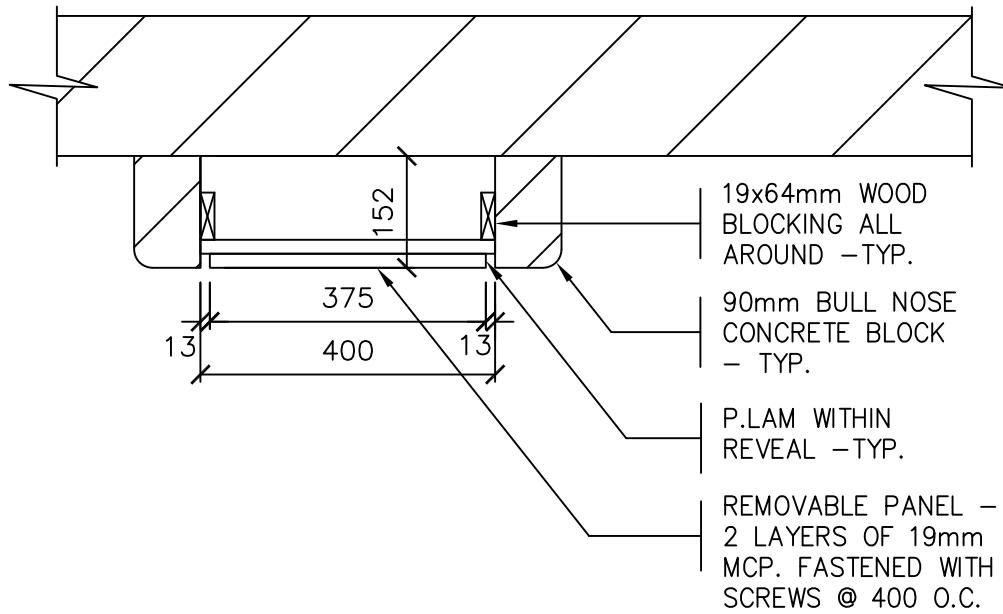

PLAN-WALL PANEL

1  
A155

SCALE 1: 10

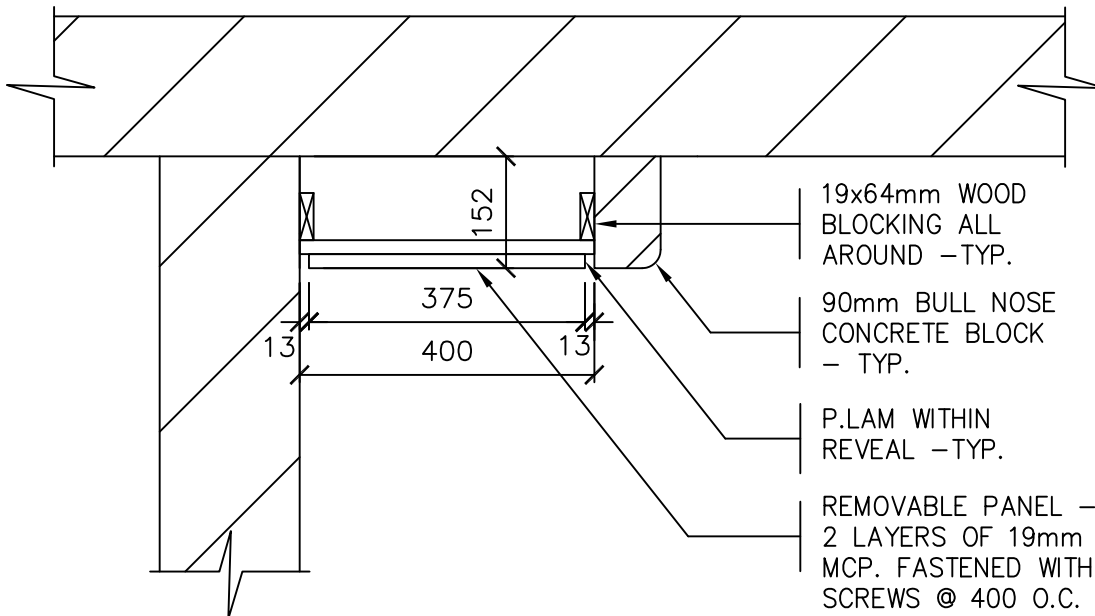

PLAN-CORNER PANEL

2  
A155

SCALE 1: 10

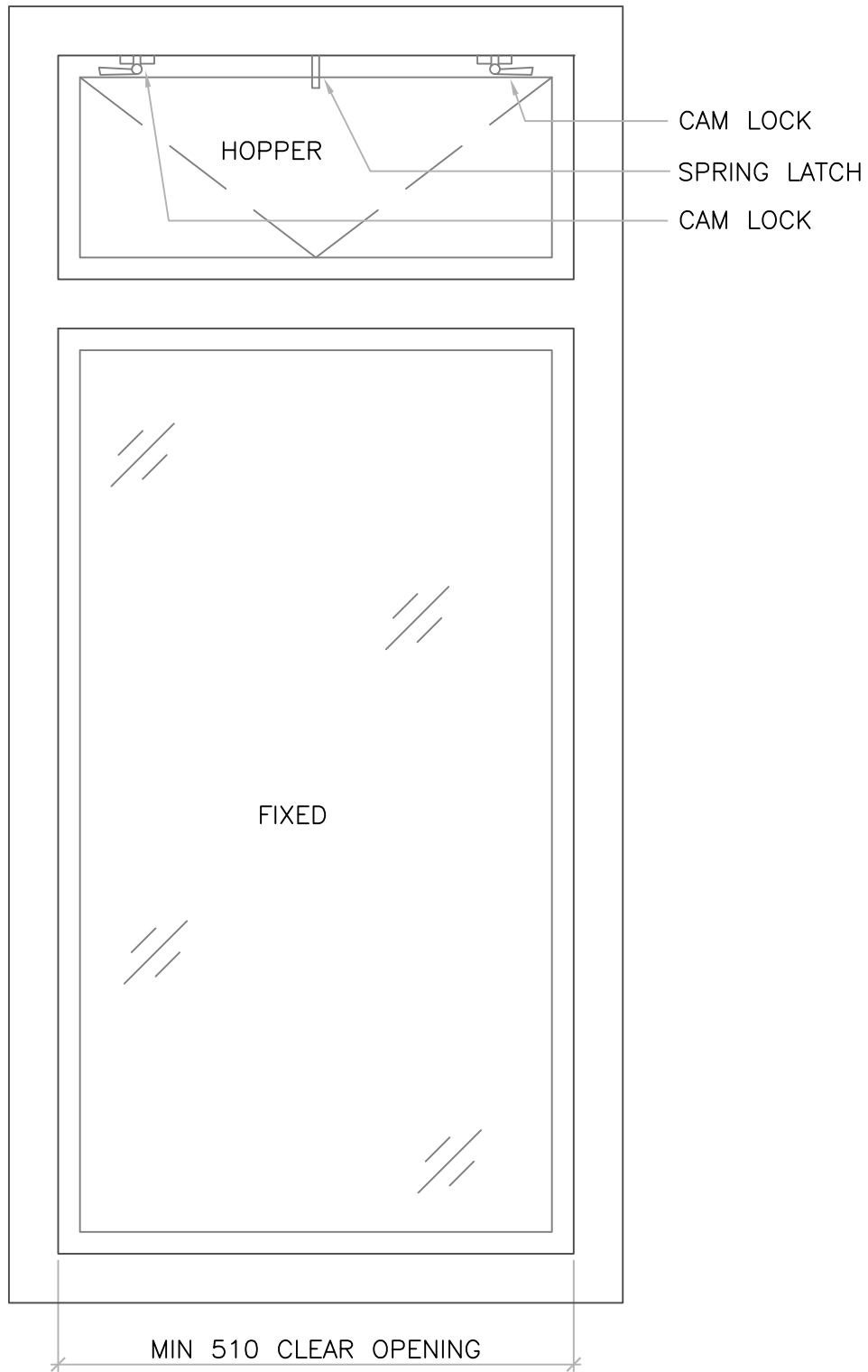

# ELEVATION – WINDOW UNIT

SCALE 1 : 10

	<b>project</b> STANDARD LAYOUTS	<b>date</b> 2023/06/28
	<b>title</b> WINDOW – ELEVATION	<b>drawing no.</b> A156 Rev. 1

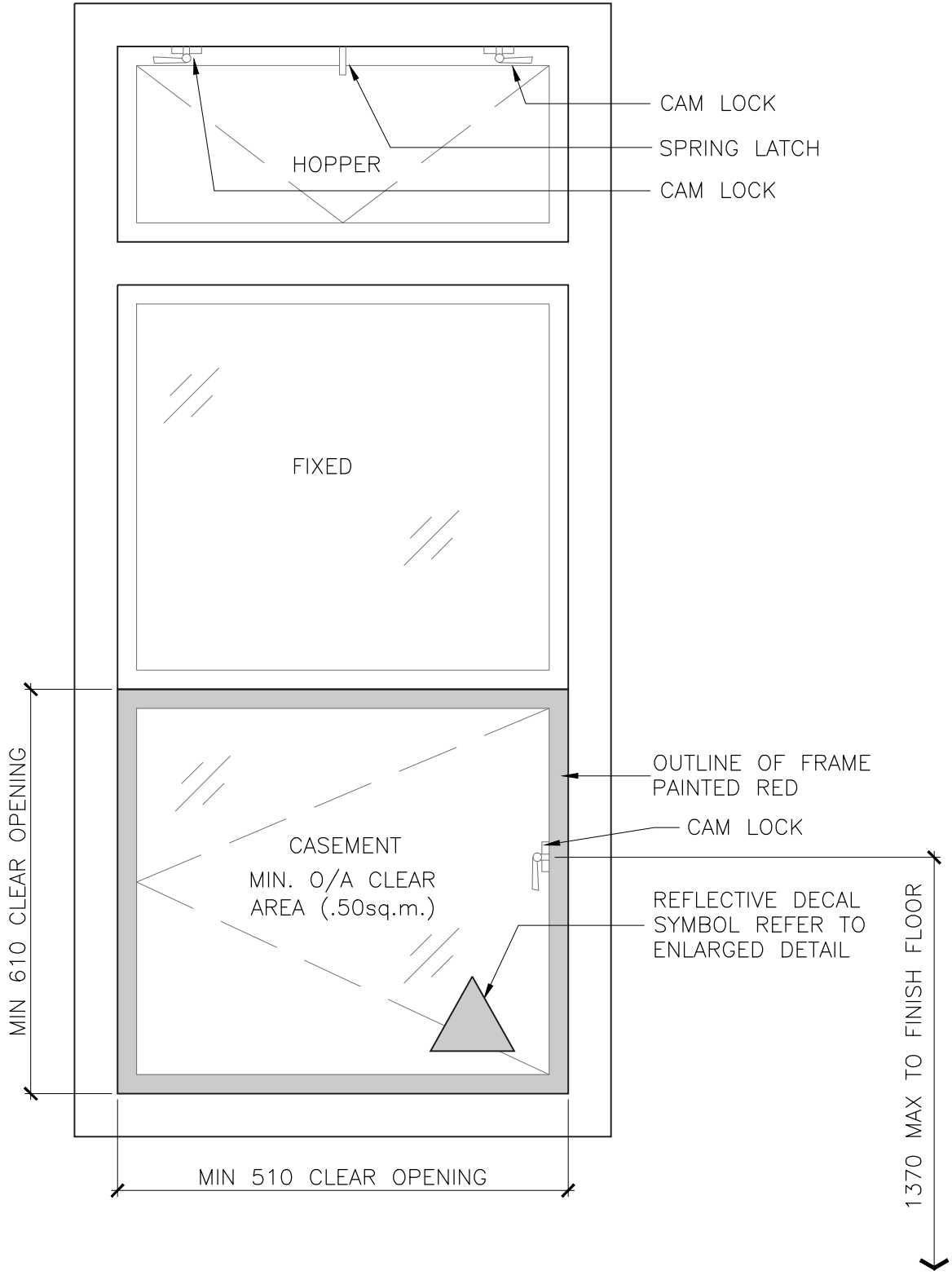

**WINDOW – EGRESS – ELEVATION**

SCALE 1 : 10

	project STANDARD LAYOUTS	date 2023/06/28
	title WINDOW – EGRESS – ELEVATION	drawing no. A157 Rev. 1

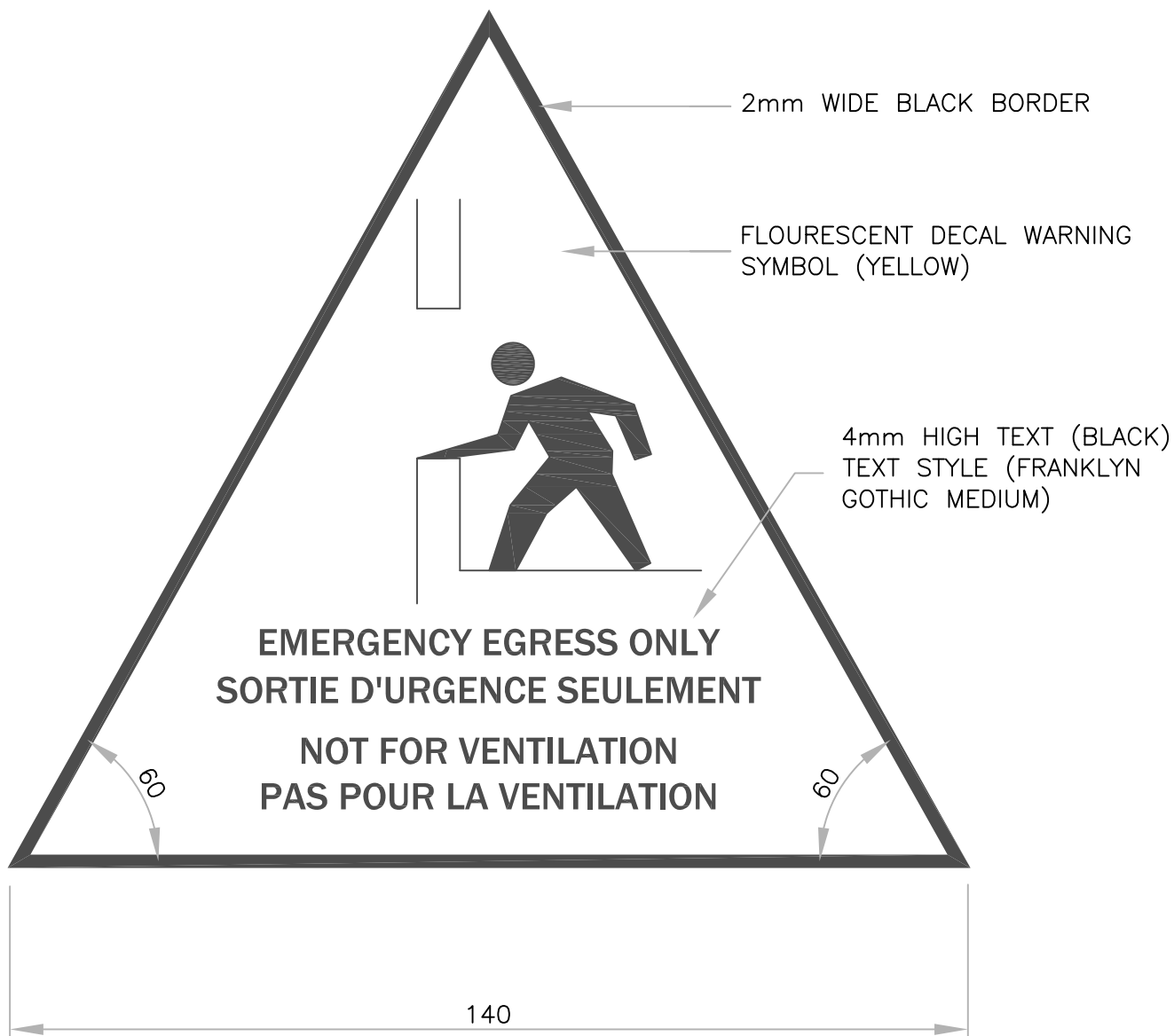

## WINDOW — EGRESS — DECAL

SCALE 1 : 1

	<b>project</b> STANDARD LAYOUTS	<b>date</b> 2023/06/28
	<b>title</b> WINDOW — EGRESS — DECAL	<b>drawing no.</b> A158 Rev. 0

## **APPENDIX B – SITE SELECTION CRITERIA**

**School Site Selection Scoring Matrix - January, 2023**

**Notes for scoring:**

Site specific "no go" aspects will be identified that supercede point comparison (e.g. min. requirements).

Points are qualitatively assigned based on level of difficulty/cost anticipated to utilize the site/address any shortcoming.

Criterion	Description	Guidance for scoring (0-5 points per line)	Site Score
			<b>100.00%</b>
<b>Characterstics</b>	Size	7-10 acres preferred (urban) .5 point/acre	5
	Length to width ratio	Qualitative - generally avoid sites above 2:1 ratio	5
	Topography	Prefer flat site	5
	On site water/climate change impact	Prefer dry land - minimizing requirement for water diversion/retention features	5
			5.00
<b>Features</b>	Proximity to population	Seek to maximize the percent of population living close to the school	5
	Walkability	Are there sidewalks or sufficient shoulder space for walkers?	5
	Bussing efficiency	Given other related bus runs, how efficient is this site for double/shared runs?	5
	Existing area recreation facilities	Are there adjacent playgrounds, playfields, etc. that could be readily utilized by the school population	5
	Site servicing: water and sewer	Can the school be readily tied into municipal services?	5
	Site servicing: electrical	Is there electrical capacity from the utility to service the site?	5
	Site servicing: data	Is there high speed (fibre) data services already in the area?	5
			5.00
<b>Availability</b>	Zoning	Is the area zoned to permit a school? Is there any anticipated challenge to rezoning if that is required?	5
	For sale now/willing seller	While expropriation is an option, the preference is to avoid	5
	Number of property owners	Increasing number of property owners increases the complexity of acquisition	5
			5
<b>Safety</b>	Setback from major roads	Can the school be located to avoid any associated traffic hazards?	5
	Police/Fire/Ambulance	Are there emergency services available?	5
	Proximity to electrical/telecom facilities	Seek to avoid cell towers, sub-stations, etc.	5
	Soil contamination	Is there any known soil contamination?	5
		5.00	
		<b>Site Score Site Score</b>	<b>100.00%</b>



## **APPENDIX C – SOUND TRANSMISSION RATINGS**

Building Area	Grade Level	Room Name	Item	Sound Transmission Class	
				SPM	ANSI
Arts Education – Theater	K-12	Theatre	Floors	-	
			Walls	48	
			Ceilings	48	
			Doors	48	
			Door Frames	48	
			Floors	-	
			Walls	-	
			Ceilings	-	
			Doors	-	
			Door Frames	-	
Arts Education – Theater	K-12	Drama Storage	Floors	-	
			Walls	-	
			Ceilings	-	
			Doors	-	
			Door Frames	-	
Arts Education – Music	K-12	Music	Floors	-	-
			Walls	48	60
			Ceilings	48	60
			Doors	48	-
			Door Frames	48	-
Arts Education – Music		Office/Conference Room	Floors	-	-
			Walls	-	60
			Ceilings	-	60
			Doors	-	-
			Door Frames	-	-
Arts Education – Music	K-12	Instrument Storage	Floors	-	
			Walls	-	
			Ceilings	-	
			Doors	-	
			Door Frames	-	
Arts Education – Music	K-12	Practice	Floors	-	-
			Walls	55	60
			Ceilings	55	60
			Doors	55	-
			Door Frames	55	-
Arts Education – Visual	K-12	Art	Floors	-	
			Walls	48	
			Ceilings	48	
			Doors	-	
			Door Frames	-	
Classrooms	K	Kindergarten	Floors	-	-
			Walls	48	50
			Ceilings	48	50
			Windows	-	41
			Doors	-	-
Classrooms	K	Kindergarten Washroom	Floors	-	-
			Walls	-	50
			Ceilings	-	50
			Windows	-	41
			Doors	-	-
Classrooms	1-3	Primary	Floors	-	-
			Walls	48	50
			Ceilings	48	50
			Windows	-	41
			Doors	-	-
Classrooms	4-6	Elementary	Floors	-	-
			Walls	48	50
			Ceilings	48	50
			Windows	-	41
			Doors	-	-
			Floors	-	-
			Walls	48	50
			Ceilings	48	50
			Windows	-	41
			Door Frames	-	-

Building Area	Grade Level	Room Name	Item	Sound Transmission Class	
				SPM	ANSI
Classrooms	7-12	Intermediate/High	Floors	-	-
			Walls	48	50
			Ceilings	48	50
			Windows	-	41
			Doors	-	-
			Door Frames	-	-
Distance Education	K-12	Classroom	Floors	-	-
			Walls	48	50
			Ceilings	48	50
			Windows	-	41
			Doors	-	-
			Door Frames	-	-
Home Economics	7-12	Home Economics	Floors	-	-
			Walls	48	-
			Ceilings	48	-
			Doors	-	-
			Door Frames	-	-
			Learning Resource Center	K-12	Learning Resource Center (LRC)
Walls	48	-			
Ceilings	48	-			
Doors	-	-			
Door Frames	-	-			
Learning Resource Center	K-12	Server Room			
			Walls	-	-
			Ceilings	-	-
			Doors	-	-
			Door Frames	-	-
			Learning Resource Center	K-12	A/V Equipment Room
Walls	-	-			
Ceilings	-	-			
Doors	-	-			
Door Frames	-	-			
Multi-Purpose Room	K-12	Multi-Purpose Room			
			Walls	48	-
			Ceilings	48	-
			Doors	-	-
			Door Frames	-	-
			Physical Education	4-12	Gym
Walls	48	60			
Ceilings	-	60			
Doors	-	-			
Door Frames	-	-			
			Walls	-	-
			Ceilings	-	-
			Doors	-	-
			Door Frames	-	-
			Physical Education	4-12	Equipment Room
Walls	-	-			
Ceilings	-	-			
Doors	-	-			
Door Frames	-	-			
Physical Education	4-12	Instructor's Office			
			Walls	-	45
			Ceilings	-	45
			Doors	-	-
			Door Frames	-	-
			Physical Education	4-12	Instructor's Washroom
Walls	-	53			
Ceilings	-	53			
Doors	-	-			
Door Frames	-	-			

Building Area	Grade Level	Room Name	Item	Sound Transmission Class	
				SPM	ANSI
Physical Education	4-12	Change/Shower Room	Floors	-	
			Walls	-	
			Ceilings	-	
			Doors	-	
			Door Frames	-	
Physical Education	4-12	Washrooms	Floors	-	-
			Walls	-	53
			Ceilings	-	53
			Doors	-	-
			Door Frames	-	-
Physical Education	4-12	Stage	Floors	-	
			Walls	-	
			Ceilings	-	
			Doors	-	
			Door Frames	-	
Science Room	7-12	Lab-Chemistry/Biology	Floors	-	
			Walls	48	
			Ceilings	48	
			Doors	-	
			Door Frames	-	
Science Room	7-12	Lab-Physics	Floors	-	
			Walls	48	
			Ceilings	48	
			Doors	-	
			Door Frames	-	
Science Room	4-12	Prep/Storage	Floors	-	
			Walls	-	
			Ceilings	-	
			Doors	-	
			Door Frames	-	
Instructional Resource	K-12	Instructional Resource Suite (IRS)	Floors	-	
			Walls	55	
			Ceilings	55	
			Doors	-	
			Door Frames	-	
Instructional Resource	K-12	IRS Washroom	Floors	-	-
			Walls	-	53
			Ceilings	-	53
			Doors	-	-
			Door Frames	-	-
Instructional Resource Room	K-12	Instructional Resource Room (IRR)	Floors	-	
			Walls	48	
			Ceilings	48	
			Doors	-	
			Door Frames	-	
Applied Tech/ Skilled Trades	7-12	Design/Planning	Floors	-	
			Walls	48	
			Ceilings	48	
			Doors	-	
			Door Frames	-	
Administrative Suite	K-12	Principal	Floors	-	
			Walls	48	
			Ceilings	48	
			Doors	48	
			Door Frames	48	
Administrative Suite	K-12	Vice-Principal	Floors	-	
			Walls	48	
			Ceilings	48	
			Doors	48	
			Door Frames	48	
Administrative Suite	K-12	Reception/Clerical	Floors	-	
			Walls	48	
			Ceilings	48	
			Doors	-	
			Door Frames	-	

Building Area	Grade Level	Room Name	Item	Sound Transmission Class	
				SPM	ANSI
Administrative Suite	K-12	Copy	Floors	-	
			Walls	-	
			Ceilings	-	
			Doors	-	
			Door Frames	-	
Administrative Suite	K-12	Data Storage	Floors	-	
			Walls	-	
			Ceilings	-	
			Doors	-	
			Door Frames	-	
Administrative Suite	1-12	Student Sick Room	Floors	-	
			Walls	48	
			Ceilings	48	
			Doors	-	
			Door Frames	-	
Lunch/Kitchen	1-12	Kitchen	Floors	-	
			Walls	48	60
			Ceilings	48	60
			Doors	-	
			Door Frames	-	
Lunch/Kitchen	1-12	Canteen	Floors	-	
			Walls	-	
			Ceilings	-	
			Doors	-	
			Door Frames	-	
Guidance & Itinerant Suite	K-12	Waiting/Display	Floors	-	
			Walls	48	
			Ceilings	48	
			Doors	-	
			Door Frames	-	
Guidance & Itinerant Suite	K-12	Guidance Counselor	Floors	-	
			Walls	48	
			Ceilings	48	
			Doors	48	
			Door Frames	48	
Guidance & Itinerant Suite	K-12	Itinerant Office	Floors	-	
			Walls	48	
			Ceilings	48	
			Doors	-	
			Door Frames	-	
Student Infirmary	K-12	Student Infirmary	Floors	-	
			Walls	-	
			Ceilings	-	
			Doors	-	
			Door Frames	-	
Student Infirmary	K-12	Washroom	Floors	-	-
			Walls	-	53
			Ceilings	-	53
			Doors	-	-
			Door Frames	-	-
Staff Suite	K-12	Staff Room	Floors	-	
			Walls	48	
			Ceilings	48	
			Doors	-	
			Door Frames	-	
Staff Suite	K-12	Staff Prep Room	Floors	-	
			Walls	48	
			Ceilings	48	
			Doors	-	
			Door Frames	-	
Staff Suite	K-12	Staff Washroom	Floors	-	-
			Walls	-	53
			Ceilings	-	53
			Doors	-	-
			Door Frames	-	-

Building Area	Grade Level	Room Name	Item	Sound Transmission Class	
				SPM	ANSI
Storage	K-12	Garbage	Floors	-	
			Walls	-	
			Ceilings	-	
			Doors	-	
			Door Frames	-	
Storage	K-12	General	Floors	-	
			Walls	-	
			Ceilings	-	
			Doors	-	
			Door Frames	-	
Storage	K-12	Supplies-Janitorial	Floors	-	
			Walls	-	
			Ceilings	-	
			Doors	-	
			Door Frames	-	
Storage	K-12	Supplies-Administrative	Floors	-	
			Walls	-	
			Ceilings	-	
			Doors	-	
			Door Frames	-	
Washrooms-Students	K-12	Male	Floors	-	-
			Walls	-	53
			Ceilings	-	53
			Doors	-	-
			Door Frames	-	-
Washrooms-Students	K-12	Female	Floors	-	-
			Walls	-	53
			Ceilings	-	53
			Doors	-	-
			Door Frames	-	-
General	K-12	Corridor	Floors	-	-
			Walls	48	45
			Ceilings	48	45
			Doors	-	-
			Door Frames	-	-
General	K-12	Vestibule	Floors	-	
			Walls	-	
			Ceilings	-	
			Doors	-	
			Door Frames	-	
General	K-12	Stair	Floors	-	-
			Walls	48	45
			Ceilings	48	45
			Doors	-	30
			Door Frames	-	-
General	K-12	Mechanical	Floors	-	-
			Walls	48	60
			Ceilings	48	60
			Doors	48	-
			Door Frames	48	-
General	K-12	Electrical/Telephone	Floors	-	
			Walls	-	
			Ceilings	-	
			Doors	-	
			Door Frames	-	

**Note:**

- 1) ANSI includes standards or steady background noise levels while SMP does not
- 2) ANSI includes standards for maximum reverberation times in unoccupied, furnished learning spaces while SMP does not

## **APPENDIX D – SCHOOL HVAC DESIGN GUIDE 2023**

---

# School HVAC Design Guide

---

2023

---

Department of Transportation  
and Infrastructure

Design and Construction  
Division

Government of Newfoundland  
and Labrador

---





## Contents

<b>1</b>	<b>Introduction .....</b>	<b>4</b>
1.1	Build Better Building Policy .....	4
1.1.1	Credits To Be Included .....	4
1.1.2	Preferred Approach .....	5
<b>2</b>	<b>Design References .....</b>	<b>5</b>
<b>3</b>	<b>Abbreviations.....</b>	<b>6</b>
<b>4</b>	<b>Design Criteria.....</b>	<b>6</b>
4.1	Comfort .....	6
4.2	Indoor Air Quality.....	7
4.3	Energy Criteria.....	7
4.4	Acoustic Criteria .....	8
4.5	Maintenance .....	8
4.6	Reliability.....	9
4.7	Commissioning.....	10
4.8	Warranties .....	10
<b>5</b>	<b>Heating System Design .....</b>	<b>10</b>
5.1	Systems To Be Considered .....	10
5.1.1	Electric Heating System.....	11
5.1.2	Air Source Heat Pump System .....	11
5.1.3	Geothermal Heating System .....	11
5.1.4	Hydronic Based Heating Systems.....	12
5.1.5	Other Systems For Consideration .....	12
5.2	Life Cycle Cost Analysis .....	12
5.3	Indoor Air Quality.....	13
5.4	Energy Recovery.....	14
5.5	Acoustic Consideration .....	15
5.6	Construction of Geothermal Systems .....	16
5.6.1	Borehole Heat Exchanger.....	16
5.6.2	HRVs and Fans.....	16
5.7	Maintenance Area / Access .....	17
5.8	Humidification.....	17

5.9	Humidity Control.....	17
5.10	Controls.....	18
5.11	Capital Cost Control .....	19
<b>6</b>	<b>Specialty Areas.....</b>	<b>19</b>
6.1	Gymnasiums.....	19
6.1.1	Heat Pumps.....	20
6.1.2	Other Heating Sources.....	20
6.1.3	Ductwork:.....	20
6.1.4	Hardwood Floors:.....	20
6.2	Science Labs .....	21
6.2.1	Physics.....	21
6.2.2	Chemistry / Biology.....	21
6.2.3	Laboratory Preparation Room .....	21
6.3	Home Economics.....	22
6.4	Skilled Trades / Applied Technology.....	22
6.5	Art Classrooms .....	22
6.6	Corridors .....	23
6.7	Fitness, Computer, Distance Education and Server Rooms.....	23
6.8	Classrooms.....	23
6.9	Cafeteria.....	24
6.10	Kitchen .....	24
6.11	Office Spaces.....	24
6.12	Washrooms / Change Rooms.....	25
<b>7</b>	<b>System Analysis (Energy Models).....</b>	<b>25</b>

# 1 Introduction

This guide provides guidance in the planning and design of HVAC systems for new schools in the province of Newfoundland and Labrador (NL). The intention is to provide guidance that will help ensure that HVAC systems are cost effective to construct, economical to operate, reliable and provide healthy indoor environments that are conducive to learning.

The intention of this guide is to provide design assistance while not being prescriptive and limiting creative input from the designer. The content described is based on industry practice and actual experience in school design and operation.

This document will focus on several primary design goals including:

- Indoor Air Quality
- Energy Efficiency
- Life Cycle Cost Optimization
- Maintainability
- Reliability
- Acoustic Considerations

There will be cases where direction provided in this document may not be appropriate for a specific project and it is expected that the designers and project team will evaluate and determine the 'best fit' solution. The design solutions approved by the owner project team should be based on the project specific criteria with information provided by the consultant to allow a fully informed decision.

## 1.1 Build Better Building Policy

The Government of Newfoundland and Labrador Build Better Buildings (BBB) Policy includes several requirements which impact the provision of HVAC systems for new school design. The requirements include:

- Design to the BBB Policy.
- Minimum efficiencies as per Section 4.3 of this report.
- Complete a life cycle project cost analysis using criteria in sections 4 and 5 of this report.
- Achieve a minimum of LEED Silver certification Version 4.

### 1.1.1 Credits To Be Included

In accordance with LEED V4 for schools the following points should be targeted, unless project specific issues prevent the inclusion:

- WEp1 – Outdoor Water Use Reduction
- WEp2 – Indoor Water Use Reduction
- WEp3 – Building Level Water Metering
- EAp1 – Fundamental Commissioning (shall be met)
- EAp2 – Minimum Energy Performance (shall be met)

- EAP3 – Building Level Energy Metering
- EAp4 – Fundamental Refrigerant Management (shall be met)
- EAc1 – Enhanced Commissioning (shall be met)
- EAc2 – Optimize Energy Performance
- EAc6 – Enhanced Refrigerant Management
- IEQp3: Minimum Acoustic Performance (HVAC Background Noise)
- IEQc3 – Construction IAQ Management Plan
- IEQc4 – Indoor Air Delivery Assessment
- IEQc5 – Thermal Comfort Design

### 1.1.2 Preferred Approach

The HVAC system design is often impacted by the requirement to meet LEED certification. The points being targeted must be determined early in the design phase to ensure all necessary elements are included in the mechanical design. The designer shall participate in the LEED decision making process to ensure chosen points are both viable and cost effective.

## 2 Design References

### 2.1 References

**The design of school HVAC systems shall be as per the latest edition of the following codes and standards as well as applicable acts and regulations:**

- National Building Code of Canada
- National Fire Code of Canada
- National Energy Code of Canada for Buildings
- ASHRAE 62.1 – Ventilation for acceptable Indoor Air Quality
- ASHRAE 55 – Thermal Environmental Conditions for Human Occupancy
- ASHRAE 84 – Method for Testing Air to Air Heat/Energy Exchangers
- ASHRAE 90.1 – Energy Standard for Buildings Except Low Rise Residential Buildings
- ASHRAE Advanced Energy Design Guides for K-12 School Buildings
- CAN/CSA-B139 - Installation Code for Oil Burning Equipment
- CAN/CSA-B51 – Boiler, Pressure Vessel and Pressure Piping Code
- CAN/CSA-C448 – Design and Installation of Earth Coupled Energy Systems
- CAN/CSA Z316.5 – Fume Hoods and Associated Exhaust System
- NFPA 96 – Standard for Ventilation Control and Fire Protection of Commercial Cooking Operations
- NFPA 45 - Standard on Fire Protection for Laboratories Using Chemicals
- LEED Canada for New Construction and Major Renovations
- TI Project Management and Design Administration Manual
- ASHRAE Handbooks
- SMACNA Standards

- ACGIH - Industrial Ventilation: A Manual of Recommended Practice for Design
- TI School Planning Manual
- NL Build Better Buildings Policy
- NL Fire and Life safety Guidance Document

### 3 Abbreviations

#### 3.1 List of Abbreviations

The following abbreviations are employed throughout the School HVAC Design Guide:

AHRI	Air Conditioning, Heating, and Refrigeration Institute
ASHRAE	American Society of Heating, Refrigerating and Air-Conditioning Engineers
BBB	Build Better Buildings Policy
CaGBC	Canadian Green Building Council
COP	Coefficient of Performance
DDC	Direct Digital Control
EER	Energy Efficiency Ratio
EMCS	Energy Management Control System
HRV	Heat Recovery Ventilator
HVAC	Heating, Ventilating and Air Conditioning
IAQ	Indoor Air Quality
LAN	Local Area Network
LEED	Leadership in Energy and Environmental Design
MERV	Minimum Efficiency Reporting Value
NEMA	National Electrical Manufacturers Association
O&M	Operation and Maintenance
SEER	Seasonal Energy Efficiency Ratio
STC	Sound Transmission Class
VFD	Variable Frequency Drive

### 4 Design Criteria

#### 4.1 Comfort

The HVAC systems shall be designed to achieve the following minimum indoor comfort conditions:

Minimum indoor air temperature	22°C (for gymnasiums 19°C)
Maximum indoor air temperature	24°C (air conditioned spaces)
Minimum indoor relative humidity	30%
Outdoor design conditions	2 <sup>1</sup> / <sub>2</sub> % January value (from NBCC)
Maximum space air velocity	Summer: 0.25 m/s

	Winter: 0.15 m/s
Minimum cooling air supply temperature	13°C
Maximum heating air supply temperature	40°C
Maximum space carbon dioxide levels	1000 ppm
Minimum gym indoor relative humidity	40% (For schools with hardwood gym floor confirm actual upper limits with floor manufacturer)
Maximum gym indoor relative humidity	60% (For schools with hardwood gym floor confirm actual upper limits with floor manufacturer)

## 4.2 Indoor Air Quality

The quantity of fresh air which shall be provided for all school spaces shall be as per ASHRAE 62.1 latest edition. In addition, ventilation shall be provided to address specific pollutants expected in the various spaces.

The minimum supply air filter efficiency of all central air handling equipment shall be MERV 13 and as per any LEED specific requirements.

## 4.3 Energy Criteria

The HVAC systems shall be designed to exceed the requirements of the Model National Energy Code of Canada 1997 for Buildings by a minimum of 25%, in addition to meeting the energy criteria for the current version of LEED. The capacity of HVAC systems shall match design loads and avoid overdesign except in specific cases where consideration for future expansion is made.

In addition, the minimum criteria shall be followed:

Minimum sensible heat recovery efficiency	55%
Minimum enthalpy heat recovery efficiency	75%
Electric motors	NEMA premium efficiency
Fan power	0.84 W per L/s
Rooftop heat pump unit SEER <sup>5</sup>	14Btu/Wh (5 tons and under)
Rooftop A/C unit EER <sup>6</sup>	14.8 Btu/Wh (over 5 tons)
Mini-split unit SEER <sup>5</sup>	13.4 Btu/Wh ( 5 tons and under)
Water to water geothermal COP	2.5 (@ 37°C HWS & @ 0°C EWT)
Water to air geothermal COP	3.2 (@ 0°C EWT)
Air to water heat pump COP <sup>4</sup>	1.5 (@37°C HWS & -10°C OAT)
Maximum annual HVAC energy <sup>1,2,3</sup>	90 kWh/m2 (@4800 °C degree days)

### Notes:

1. The above energy target will meet ASHRAE 50% Energy Savings Target above ASHRAE 90.1.
2. Includes space heating, humidification, pumping, fresh air heating, and fan energy.
3. Correlate target baseline energy above to actual location degree days.
4. Heat pump COP includes all defrost losses.
5. SEER to be as defined in AHRI Standard 210/240.
6. EER to be as defined in AHRI Standard 340/360.

#### 4.4 Acoustic Criteria

The HVAC design should incorporate design solutions and specific acoustic controls to ensure mechanically generated noise in the following spaces are below the levels indicated. The room criteria (RC) sound rating procedure as defined in ASHRAE Applications Handbook shall be used to evaluate performance of the HVAC systems. Vibration based noise of HVAC equipment shall also be considered and mitigated.

	ASHRAE 2015 NC/RC	dB(A)
Classrooms	30	35
Gym	45	50
Music room	25	30
Home economics	35	30
Labs	35	40
Skilled trades & applied technology room	35	40
Performing arts spaces	20	25
Corridors	40	45
Library	30	35
Offices	30	35
Open Plan	40	40 - 45

#### 4.5 Maintenance

Maintenance is becoming more important as mechanical systems become more complicated to ensure systems operate as originally intended. There are numerous elements that can be incorporated into the HVAC design to aid operational maintenance staff with both maintaining equipment and troubleshooting any problems. Some of these include:

- Provision of adequate equipment access, rooftop or otherwise.
- Provision of analog filter differential pressure transducers.
- Use of BACnet connections to equipment whenever possible with all alarm/status points available on DDC front end.
- Use of non-drift non-dispersive infrared CO2 sensors requiring no re-calibration over lifetime.
- Provision of DDC alarms to indicate failure of any mechanical equipment.
- Use of analog current transducers on all fan/pump motors to indicate actual running amps.
- Automatic lead to lag equipment switchover on lead equipment fail (boilers, pumps, etc.).
- Automatic glycol make-up system with low level alarm.
- Provision of O&M manuals that are complete and detailed for all equipment installed.
- Provision of strainers, sediment filters and chemical treatment stations on all glycol and hot water heating loops. Strainers or sediment filters on each pump when duty and standby pumps are used. When a single pump is utilized use dual strainers and filters to facilitate servicing.

- Any hydronic heat pump system shall use an environmentally friendly glycol c/w inhibitor as the transfer medium. Water shall not be used as a transfer medium.
- Provision of valve arrangements that allow the bypass, isolation of, and ability to chemically clean equipment including heat exchangers, heat pumps and air handling coils.
- Flow meters, temperature sensors and pressure gauges shall be installed after all pumps and on the discharge of any central heat pump system. All readings shall be monitored by the DDC.
- Provision of corrosion monitoring coupons in hydronic system piping.

## 4.6 Reliability

The best approach to providing reliability is through simplifying the HVAC system. This however often conflicts with the requirement for reduced energy consumption. The designer's focus therefore should be on enhancing reliability even with the challenge of more complex system designs.

Consideration should give to locating all HVAC equipment in the interior or in a penthouse. When this cannot be achieved, outdoor shall consider suitable materials for weather protection.

The following is a list of reliability enhancements that shall be considered in a school HVAC design:

- Geothermal not sized for full heating load but between 50-66% of the heating load. The remainder of the load by electric boilers sized for the balance or size for 66% of the load should the geothermal field fail.
- Provision of spare piped geothermal pumps.
- Use of bypass contactors on all VFD's.
- Use electric heating as the primary source (electric baseboard, electric boiler, electric fan coils, etc.). All hydronic heating components to be isolated with ball valves and to have drain valves for sediment removal. All other isolating valves to be ball valves, not gate valves.
- Separate geothermal well piping with main header located inside building with maximum of 4 wells on each individual branch loop from building.
- Inclusion of programming for automatic switchover to backup heating. Provide proof of function during commissioning.
- Provision of automatic glycol make-up system with alarms for low system pressure. Alarms to be both audible with manual reset and connected to the DDC system.
- Ensure duct access is provided for all in duct equipment including motorized dampers, coils, humidifier distributors, sensors, etc. Ensure no interference with the ceiling grid.
- Specification of extended warranty for heat pump compressors, VFD's, and other components.
- Provision of spares for key components as recommended by the manufacturers. (e.g. Spare heating circulating pumps and associated VFD's).
- Any oil fired boilers shall be redundant with capacity for 66% design loads possible on one boiler failure, or size three boilers at 50% of the design load as an alternative.
- Mechanical pump seals.



## 4.7 Commissioning

The commissioning of the school HVAC system is an important element as the proper operation of the thermal control and IAQ systems are critical to the school operation. The performance verification is the opportunity to fully test and confirm all aspects of the HVAC system prior to the building being occupied. This allows problems with set-up and equipment to be identified and resolved prior to students and staff using the school. All commissioning activities shall follow the Commissioning Manual and Specifications for the project.

During the design stage it is important to consider commissioning as the inclusion of such things as sensors which will improve commissioning and aid in system set-up. Items to consider include the following:

- The use of 3<sup>rd</sup> party commissioning agent.
- Provision of air flow measuring stations on main branch ducts. The amount and location to be coordinated with Transportation and Infrastructure.
- Provision of temperature sensors in supply ducts of all heat pumps.
- Provision of temperature sensors in all duct connections to heat recovery units.
- Provision of temperature sensors in geothermal supply and return piping.
- Provision of current transducers on pump/fan motors (or use VFD current input).
- Use of end switches on damper actuators to prevent fan motors from starting before intake and exhaust dampers are fully opened. Add a second end switch as feedback to the building management system.
- Inclusion of flow metering in geothermal piping mains.
- Provision of temperature sensors before and after all heat pumps and heat exchangers.
- Provision of temperature sensors in supply and return ducts of AHUs.
- Provision of CO2 sensors in return ducts to control outside air quantities.

## 4.8 Warranties

It is required that a warranty inspection be undertaken to identify any system operational issues as well as warranty replacement requirements. Any adjustments required to the HVAC system operation to improve comfort or IAQ should be documented for Department consideration.

# 5 Heating System Design

## 5.1 Systems To Be Considered

There are many potential systems which can be designed to provide heating for a school. Each would generally provide an operational solution however, the capital costs, energy implications and reliability differ greatly with each option.

The goal in the design of a school heating system is to provide a comfortable environment with a high degree of occupant space temperature control. The goals of low energy costs, reliability and maintainability are also elements that must be considered.

### **5.1.1 Electric Heating System**

The traditional method to heat a new school has been with an electric based heating system. This method may not be the most energy efficient, but does provide a very high reliability factor, has low annual maintenance costs and relatively low constructions costs which is an important consideration to the operating school district. These systems are generally simple and with each space heated independently, a failure of one heater does not affect the remaining spaces. Electrical heated schools to use demand shedding.

### **5.1.2 Air Source Heat Pump System**

- The air source heat pump components shall be designed to meet the heating requirements at the mean winter temperatures and not the peak design temperatures.
- An electric boiler, electric fan coils, etc. shall be incorporated to supplement and provide redundancy to the air sourced heat pump.
- Secondary heating sizing should be limited to the actual classroom heating loads with internal heat generation excluded.

### **5.1.3 Geothermal Heating System**

- The geothermal heating system components shall be designed to meet the heating requirements at the mean winter temperatures and not the peak design temperatures.
- The reliability of the geothermal heat pump system is often a major concern of the school district. To eliminate the potential of school closures due to ‘heating problems’ a secondary electric system shall also be provided.
- This system would serve two purposes, with one being the provision of reliability and the other being supplemental heating required to meet peak heating loads. As the geothermal system should only be sized for mean winter temperatures, the savings associated with this optimization will offset the costs associated with installing the secondary heating.
- Secondary heating sizing should be limited to the actual classroom heating loads with internal heat generation excluded.
- Given that it is supplemental only, any ‘oversizing’ of the supplemental system should be avoided.
- Size the secondary heating to meet 100 % of the heating load should the geothermal fail.

#### **5.1.3.1 Closed Loop Arrangement**

- There are several design challenges associated with this geothermal system including ease of maintenance, reliability, and noise generation. Each of these will need to be addressed in the design of the HVAC system and building systems.
- One of the challenges of a closed loop system is the difficulty in maintaining the heat pumps which are often located in ceiling spaces. To allow ease of maintenance, the preferred location of the heat pumps should be an accessible service space rather than a ceiling space.
- Circuit setters would be required to balance all hydraulically unique piping zones.
- The system should also have the ability to recirculate the glycol mixture when the interior loop temperatures are above the well temperatures up to a pre-set maximum. This design element greatly improves overall system efficiency when there are zones within the school in heating

mode and others in cooling mode. The efficiency of those heat pumps in heating mode increases greatly with an increase in the fluid temperatures.

#### **5.1.4 Hydronic Based Heating Systems**

- An oil based heating system should only be considered in remote communities operating on diesel generators. This is to be determined based on consultation with Transportation and Infrastructure and the Department of Education.
- In other cases, electric boilers with hydronic distribution can be considered.
- In these schools central hot water boiler systems should be used with baseboard hydronic heating.
- Boilers should be sized with redundant capacity for 66% design loads possible on one boiler failure, or three boilers at 50% capacity each.
- All heating circulator pumps should be provided with a piped spare.
- Oil tanks are to be above ground double wall with all above ground piping to limit the risk potential associated with an oil leak. Provide leak detection with annunciation at the DDC system or some central location.
- All oil piping to be adequately supported and protected from damage.
- Oil tanks are to be sized to suit the estimated consumption between realistic fill times. In some locations this will require sizing the oil storage tank for the full year.

#### **5.1.5 Other Systems For Consideration**

Since a priority of this guide is to provide design assistance, and not limit creativity or innovation in design, a prescriptive approach to setting a specific heating system has been avoided. This will help our new schools to progressively incorporate new heating designs that will improve comfort levels, increase reliability and be cost-effective. In addition, many schools differ in size, construction, shape, orientation, geographic location, etc. A one size fits all solution is not the best way to approach HVAC design.

Such systems for consideration may include:

- Hybrid systems – The idea here is that a small heat pump system can maintain the setback temperature during unoccupied periods such as nighttime and weekends. The electric heat will help maintain classroom temperatures during occupied periods. This helps keep capital costs low, while still incorporating energy efficiency in design. This type of system has been used in a school with only six geothermal wells.
- Ductless heat pump system – In cases where the school size and layout permits, a ductless heat pump solution supplemented with electric baseboard heaters may be the most efficient and cost effective solution.

## **5.2 Life Cycle Cost Analysis**

A Life Cycle Cost Analysis shall be completed for the project to compare several HVAC system options for consideration. The systems which should be included in the lifecycle analysis shall be as follows:

- Electric heating system;

- Air to water heat pumps;
- Air to air heat pumps;
- Geothermal heat pumps;
- Hydronic based heating system with prior department approval; and
- Other systems with prior department approval.

The following values are to be used in the analysis:

Length of analysis	20 yrs
Electricity cost inflation	2.65% /yr
Fuel oil cost inflation	3.75% /yr
Maintenance cost inflation:	2% /yr
Discount rate:	6.0%

A template can be provided for the Lifecycle Cost Analysis.

The designer shall also complete a cost benefit analysis of a demand controlled ventilation system for the school to determine the suitability of this system based on actual expected population diversity. The analysis shall be an economic present worth analysis and include capital costs, energy savings, maintenance costs, etc. The system shall be used in the school design if it has a lower present worth than a constant volume heat recovery system.

### 5.3 Indoor Air Quality

- All spaces in the school shall be provided with fresh air rates set forth in ASHRAE 62.1 most recent edition.
- Areas having potential for dust or odour generation shall have relative pressurization to control these contaminants. These areas would generally consist of technical education spaces, art rooms, kitchens, home economics, cafeteria, chemistry preparation rooms and chemistry labs.
- Control of return air is critical to ensure the overall building pressurization is maintained in a demand controlled system.
- The location and design of air intakes should be a primary consideration in the HVAC design. The minimum distances outlined in ASHRAE 62.1 most recent edition shall be followed. Generally, intakes should not be located adjacent to bus loading areas or student drop off areas, parking areas, exhaust for other equipment, or other potential site related containment sources.
- Ground level intakes should generally be avoided as they are more prone to contaminant intake and snow entrainment. The design of the intakes should be such that low air velocity limits the potential for snow and water entrainment.
- Storm proof 100mm deep louvres with baffles installed in front should be used. The sizing and location of the baffles shall be coordinated with the architect to ensure the velocity at the baffle openings is below 2.0 m/s to limit snow entry.
- Thermally insulated intake plenum rooms which have positive drainage and waterproof base liners should be used whenever possible. These rooms should be sized to limit air velocity and encourage any entrained snow to drop to the floor of the plenum.

## 5.4 Energy Recovery

- All central school ventilation systems shall utilize heat recovery units.
- To further enhance energy recovery, the use of both latent and sensible heat recovery ventilation should be employed to extract heat contained in the school exhaust air streams.
- Areas of the province having extreme design conditions shall use static plate type sensible heat recovery only.
- Depending on the manufacturer, fresh air pre-heat may be required to ensure correct unit operation. This must be confirmed early in the design process.

See below for recommended design conditions and associated unit types:

NBCC 2 1/2% Design temperature <-25°C	Static plate heat recovery Minimum effectiveness: $\epsilon = 55\%$
NBCC 2 1/2% Design temperature >-25°C	Enthalpy wheel heat recovery Minimum effectiveness: $\epsilon = 75\%$

Heat recovery effectiveness to be calculated using ASHRAE Standard 84 with the following equation:

$$\epsilon = (w_{sa} (e_{sa} - e_{oa})) / (w_{min} (e_{ra} - e_{oa}))$$

Where:

$\epsilon$	=	Effectiveness
$w_{sa}$	=	Supply air mass flow rate
$w_{min}$	=	Smaller of Supply air and Exhaust air mass flow rate
$e_{sa}$	=	Supply air enthalpy
$e_{ra}$	=	Return air enthalpy
$e_{oa}$	=	Outside air enthalpy

- For a static plate heat exchanger, cold corner or traversing type defrosts would be the preferred methods, or use exhaust air for defrosting.
- For the enthalpy type exchangers, wheel speed control is the preferred method as this provides the greatest control and efficiency.

To aid in the analysis of potential system choices, the following energy consumption numbers can be used as guidance for overall discussion only. The operation of each facility is different and would cause some different energy results.

These energy consumption numbers are total actual annual energy consumption values and based on 2011 meter data:

Laval High Geothermal variable volume ventilation	102 kWh/m <sup>2</sup>
Elizabeth Park Elementary	122 kWh/m <sup>2</sup>

Geothermal variable volume ventilation	
Mobile Central High Electric heat constant volume ventilation	193 kWh/m <sup>2</sup>
French Shore Academy Electric heat constant volume ventilation	190 kWh/m <sup>2</sup>
Baccalieu Collegiate Electric heat variable volume ventilation	176 kWh/m <sup>2</sup>

## 5.5 Acoustic Consideration

The HVAC system shall be designed to minimize generated and transmitted noise. Unwanted noise in a school environment has a negative impact on student learning and project specific acoustic design criteria should be documented early in the design stage. The mechanical designer must consider noise criteria in all aspects of the HVAC system design from equipment selection and duct sizing to grille selection. To ensure accuracy of the estimated HVAC noise levels the HVAC design shall include acoustic design software simulations. LEED IEQp3: requires a minimal acoustic performance.

The following are strategies which shall be considered to enhance acoustic performance in the school HVAC design:

- Location of high STC mechanical spaces above non noise critical spaces such as washrooms, storage rooms, etc.
- Use of plenum fans in HRVs.
- Use of main duct silencers at HRV unit locations inside the mechanical room and near the mechanical room walls.
- Eliminating branch connections to HRV mains immediately after unit.(Increase first branch duct length and add elbows to provide sound transmission loss)
- Location of heat pumps in purpose designed rooms with STC ratings of 45.
- Selection of low generated noise heat pump options such as compressor blanket, larger fan blower, heavy gauge cabinet, internal insulation, enhanced compressor vibration mounts, etc.
- Use of acoustic duct lining downstream of heat pumps.
- Use of acoustic duct lining in transfer ducts.
- Location of ceiling plenum return grilles away from transfer ducts and heat pump return ducts.
- Sizing of branch supply ducts to classrooms with low velocity and generally lower than 3.6 m/s (700 fpm).
- Selection of grilles and diffusers to ensure low generated noise values (Grilles selected with lower the NC rating of the room).
- Selection of high volume ducted grilles such as gym return grilles at extremely low core velocity of 1.3 m/s (250fpm).
- Increase supply and return duct gauges one or two gauge sizes heavier at AHU/HRV discharge and return connections to reduce low frequency noise.

## 5.6 Construction of Geothermal Systems

Whenever possible the borehole design should be based on actual borehole thermal conductivity tests with the test borehole configuration matching the final borehole design.

### 5.6.1 Borehole Heat Exchanger

Recent Examples of Thermal Conductivity Testing:

Placentia	Conductivity: 2.47 W/m•K (1.43 Btu/hr•ft•°F) Thermal diffusivity: 0.94ft <sup>2</sup> /day (0.0101cm <sup>2</sup> /s) (well included 50m of casing to bedrock)
Paradise	Conductivity: 2.98 W/m•K (1.72 Btu/hr•ft•°F) Thermal Diffusivity: 1.06ft <sup>2</sup> /day (0.0114cm <sup>2</sup> /s)
St. John's (RNC Complex)	Conductivity: 2.20 W/m•K(1.27 Btu/hr•ft•°F) Thermal Diffusivity: 0.81ft <sup>2</sup> /day (0.0087cm <sup>2</sup> /s)

- In order to model a borehole field properly an accurate estimate of the building annual energy use is required. Software programs such as Carrier HAP, Trane Trace and eQuest can provide monthly outputs of the heating energy required from a borehole field and the cooling energy being rejected to the field. The software used must meet the requirements of LEED.
- Modelling of this data in geothermal heat exchanger simulation software such as GLHEPRO will provide field sizing outputs with predictions of long term well field performance out to 20yrs.
- The borehole field shall be sized to accommodate 60% of the predicted heating energy as determined by the modelling. This will ensure the borehole field costs are not excessive as the incremental payback does not justify full load sizing of the fields.
- The borehole field, once sized, shall be connected to an accessible header located inside the building. The wells shall be interconnected with a maximum of ¼ of the total, or maximum 4 wells per loop, and joined at the common header. In the event of any piping failure, the entire field would not be compromised.
- The fluid used for the geothermal system shall be inhibited propylene glycol.
- The grout for the wells shall be thermally enhanced grout with a thermal conductivity of 1.69 W/m°C (1.00 Btu/hr•ft•F) or better.
- The decision on the optimal depth of the borehole should include consideration of initial costs, well thermal performance, and pumping power. Generally, a borehole depth of 150m (500ft) has proven to be an acceptable balance between the above determining factors.

### 5.6.2 HRVs and Fans

- The HRV units should have insulated double wall construction with aluminum or stainless steel inner liners, fan spring isolation, belt drive premium efficiency motors, insulated low leakage aluminum dampers, hinged access doors with viewing windows, interior lighting, and stainless steel double sloped drain pans in all unit sections having potential for water build-up.
- High consideration should be given to the use of plenum fans over scroll encased centrifugal fans as plenum fans have the lowest generated sound of all fan types.

- If a scrolled encased fan is used, the duct configuration at the fan connections must not create a high static system effect condition.

## 5.7 Maintenance Area / Access

- If an interior mechanical room or rooftop penthouse is not possible to obtain, rooftop units may be utilized upon approval of Transportation and Infrastructure.
- These should be located centrally but positioned above non-noise critical spaces such as washrooms, storage rooms, corridors, etc.
- These units should have factory applied exterior coatings for corrosion resistance, such as marine grade baked enamel or epoxy based systems, 316 stainless steel or conforms to ISO 12444-9 Paints & Varnishes – Corrosion Protection of Steel Structures by Protective Paint System.
- Any drains required for rooftop heat recovery units must be drained to the building interior and not simply drained to the roof.
- Consider orienting units so the intake is not facing the prevailing wind direction. Protect the intake and exhaust openings of outdoor HVAC equipment.

## 5.8 Humidification

- Electric steam generating humidifiers with cleanable steam chambers shall be provided in all central air handling systems to introduce steam to the supply air stream downstream of main heating coils.
- Whenever possible humidifier distributors should be located within the indoor heat recovery units and have the required upstream clearance and downstream absorption distances.
- If installed in the supply duct the humidifier distributor should be located in a water tight duct section having minimum required straight duct of 0.5m upstream and 1.2 m downstream. This duct section should have an integral drain with double sloped bottom section with drain located at the low point. The humidifier distribution duct section should be constructed of welded stainless steel 316 L.

## 5.9 Humidity Control

- The HVAC design should include provisions for periodic and controlled ventilation operation in the summer months to limit humidity levels and maintain good indoor air quality.
- Strategically placed space mounted humidity sensors shall be provided to monitor humidity and start the HVAC system if humidity levels are high. This would be especially important in a gym having a hardwood floor. The control approach would depend on the system installed in the school.
- Locate humidity sensors in return ducts to measure bulk air stream relative humidity.
- The central heat recovery ventilation system shall be programmed to operate periodically to exhaust air from and provide fresh air to the building.



## 5.10 Controls

The tender design documents should also include allowances for the EMCS contractor to complete minor system fine-tuning and adjustments at the end of the one year warranty stage based on any direction provided by the department consultant.

Contractor to ensure the end user has received appropriate training, been assigned full administrator privileges to the EMCS and the Controls software has been updated to the latest version thereof before the end of the warranty period.

All new schools shall have a fully licensed energy management control system, utilizing direct digital control (DDC) to control all aspects of the HVAC systems. While the detailed requirements are specifically listed in the TI Master Specifications, the system generally shall be BACnet based open protocol with web based remote access. The system shall be designed to control the HVAC systems but also be designed to be useful in troubleshooting any operational problems. Some of the additional features which shall be considered include the following:

- Scheduling start/stop of all fans, pumps, HRVs, AHUs, etc.
- Discharge temperature sensors in heat pump, HRV and AHU supply ducts.
- BACnet connection to all heat pumps.
- BACnet connection to VFD.
- BACnet connection to humidifiers.
- DDC thermostat control of all electric heating with display only, set point adjustment at the head end and occupancy control. The DDC system to display room temperature and the setpoint temperature.
- Analog current sensing at all fan and pump magnetic starters.
- Humidity sensors downstream of humidifier distributor end as high limit control.
- Temperature sensors upstream and downstream of heating coils.

While BACnet is a great tool to provide detailed information from each mechanical device, it should not be used as the sole means for equipment control. Many equipment vendors are using BACnet OEM boards that have very low communication speeds (ie. 19200 Baud) resulting in communication problems. This should be avoided by also providing the traditional 'on-off' or 'modulating' hard wire control from the EMCS panels in addition to the BACnet connection which can be used for detailed troubleshooting purposes.

The EMCS system should also have the ability to track energy and water use in the mechanical systems allowing the operational staff the ability to fine-tune the systems to optimize efficiency. Some additional monitoring points to monitor energy usage which should be considered are:

- Building power use (Provision of energy monitoring transducer) (EAp3)
- All motor power usage (Generally obtainable from VFD BACnet connection)
- Humidifier energy (Provide analog current relay)
- Domestic hot water tank energy (Provide analog current relay) (WEp3)

- Heat pump energy (Current sensor on each heat pump)

The EMCS system should connect the water meter output to allow monitoring of domestic water use.

The building owner will provide the internet IP or VPN to enhance the ability to troubleshoot and provide remote assistance. The design should include the requirement that the controls contractor be responsible to make any programming adjustments deemed necessary by the department for the first year of operation.

Provided the school district allows the EMCS system to be connected to their LAN, it is recommended that the system also be accessible within the school on any computer having Internet Explorer, provided adequate password protection is included. This feature aids the school staff in providing easy access for alarm indication, setpoint adjustment and schedule adjustments.

User control devices such as thermostats should be selected based on use and location. For example, only a flush plate type temperature sensor should be used in the gym. In addition the risk or vandalism should be considered in all washrooms, corridors, change rooms, vestibules, etc. and simple flush plate stainless steel temperature sensors should be used.

The design documents should also include allowances for the EMCS contractor to complete minor system fine-tuning and adjustments at the end of the one year warranty stage based on any direction provided by the department.

### 5.11 Capital Cost Control

Whenever possible the capital costs of each option should be based on actual recent project cost data which provides to most realistic comparison. Below are examples of several schools mechanical costs including HVAC, plumbing and controls.

Closed Loop Geothermal (Demand Controlled Ventilation)	\$420/m <sup>2</sup> (Avalon Region)
Closed Loop Geothermal (Constant Volume Ventilation)	\$421/m <sup>2</sup> (Metro Region)
Closed Loop Geothermal (Constant Volume Ventilation)	\$513/m <sup>2</sup> (Metro Region)
Closed Loop Geothermal (Constant Volume Ventilation)	\$510/m <sup>2</sup> (Metro Region)
Electric Heating (Demand Controlled Ventilation)	\$462/m <sup>2</sup> (Central NL)
Electric Heating (Constant Volume Ventilation)	\$443/m <sup>2</sup> (Northern Pen.)

## 6 Specialty Areas

### 6.1 Gymnasiums

- Gym supply air grilles should not be located over the playing surface as air movement will affect certain sports. Perimeter supply air grilles to wash exterior walls using drum style diffusers work well in this application as they help get heating air down to floor level.
- The grilles shall be sufficiently detailed on the design drawings with attachment necessary to prevent the grille from falling from the duct in the event the grille is struck.
- The grilles shall also have a safety chain securely attached.

- Supply air and return path silencers should be used to reduce ventilation noise.
- Provide separate occupancy schedule for the gym as it's use varies from the remainder of the school.
- Oversizing of the return air grilles and associated grille plenums to reduce air velocity has proven very successful in reducing gym ventilation noise.
- As the ventilation system is used for heating the return air grilles should be flush wall mounted type located as low as possible to promote de-stratification of the gym space.
- Return air grilles need to be high strength gym grilles specifically designed for this application.

#### **6.1.1 Heat Pumps**

- If the school has a heat pump system the gym ventilation should be provided with heat pumps located in a mechanical space adjacent to the gym.
- The heat pumps can be connected in a common supply air plenum arrangement allowing enhanced reliability, better heating capacity modulation and reduced overall noise generation vs. a large built-up air handler.
- Beyond the obvious heating energy savings another distinct advantage is the ability of this system to provide air conditioning and dehumidification to the gym when high occupant loads often result in high space temperatures and humidity levels.
- In a heat pump system with a demand controlled ventilation system, fresh air would be provided to the system from the school central heat recovery unit via carbon dioxide controlled variable air volume boxes.

#### **6.1.2 Other Heating Sources**

- If the school has an electric based or other heating source, the gym shall be provided with an air handling unit to provide the necessary heating and ventilation for the gym space.
- Fresh air shall be demand controlled to ensure the system can respond with appropriate fresh air to large occupancies.

#### **6.1.3 Ductwork:**

- As gyms often have center dividing curtains the coordination of duct routing with the architect will be required.
- Supply ducts shall be designed to be located in the open web joist space as high as possible to improve the visual aspect as well as limit interference.
- All exposed ductwork shall be spiral type and painted.

#### **6.1.4 Hardwood Floors:**

- This flooring requires careful humidity control to limit shrinkage and cupping.
- This limitation should be confirmed with the specific hardwood supplier and the systems should be designed to maintain humidity within these limits.
- This will require steam humidification and possibly the addition of mechanical de-humidification which can be added to the ventilation system.

- The mechanical designer shall determine the system requirements necessary to maintain year round humidity control required to protect the hardwood floors.

## 6.2 Science Labs

### 6.2.1 Physics

A dedicated physics only lab would not require any specific ventilation beyond that required in a normal classroom.

### 6.2.2 Chemistry / Biology

- The double sided science fume hood located between the preparatory room and laboratory requires a dedicated exhaust system that meets the requirement of CSA Z316.5 latest edition: Fume Hoods and Associated Exhaust Systems.
- The fume hood shall be a balanced draft type sized for a minimum face velocity of 0.5m/s and having consistent capture velocity regardless of sash position.
- The fume hood shall have a ventilation alarm system to indicate a low airflow condition.
- Exhaust fans serving fume hoods shall be explosion proof, purpose built for fume hood exhaust and be roof mounted with high velocity up blast discharge. Inline fans shall not be used as the fume hood ducting must operate under negative pressure.
- The fume hood and associated systems shall be independently tested prior to occupancy to confirm compliance with CSA requirements.
- All fume hood ducts shall be constructed from stainless steel to enhance corrosion resistance.
- At all times the Laboratory shall be maintained at a negative pressure with respect to all surrounding spaces.
- The return air from a science lab shall not be via a common school ceiling return plenum but through a continuous return duct to the central heat recovery unit.

### 6.2.3 Laboratory Preparation Room

- The Lab preparatory room also requires dedicated ventilation. The exhaust shall ensure the room is always under negative pressure and shall originate from both the ceiling level and from a low level to ensure capture of both lighter and heavier than air vapours.
- The lab preparatory room ventilation exhaust shall operate whenever the room is occupied and shall be initiated whenever the room lighting is on or whenever supply air from the central HRV is operating.
- An audible and visual alarm shall be activated if the exhaust ventilation is not operating when required.
- The chemical storage cabinets located in the prep room shall be ventilated using an in-line or roof mounted with vertical discharge, explosion proof exhaust fan, discharging through the roof vertically, which shall operate continuously to exhaust any potential fumes from the cabinet. This fan shall be located as close as possible to the building exterior to limit the extent of positive pressure ducting. The fan shall be spark resistant construction.

- The exhaust duct associated with these cabinets shall be stainless steel and the section that is positive pressure shall be all welded and confirmed sealed to prevent air leaks.

### **6.3 Home Economics**

- The home economics room shall include domestic range hoods for all domestic type ranges with each being rigid ducted to the school exterior.
- This space must be kept under constant negative pressure to ensure odours do not migrate to other parts of the school.
- The use of a common shared ceiling plenum return would not ensure the space is under negative pressure. The return from the home economics rooms shall be hard ducted to the heat recovery unit.

### **6.4 Skilled Trades / Applied Technology**

- Generally there are two dedicated painting/soldering areas which require ventilation in the form of back slot type hoods to promote air movement away from the student's breathing zone.
- These hoods require dedicated roof mounted up-blast exhaust fans to ensure that all ducting is under negative pressure.
- A portable dust collector will be provided by the school district so there will not be a requirement for a central dust collection system.
- The potential for fumes and odours in the fabrication shop space is high, so this space also requires a hard duct return solution to the school central HRV to ensure the fabrication space is consistently under negative pressure in relation to the remainder of the school and adjoining rooms in the applied technology suite.
- Due to the high potential for dust, the return grille should have a filter to capture dust and keep the return duct system clean. The filter should be easily accessible for routine maintenance.

### **6.5 Art Classrooms**

- The art classroom shall have hard ducted return to the main HRV.
- This space should be balanced to be under constant negative pressure. In the variable volume demand controlled system, both the supply and return ducts would be fitted with variable volume boxes and the return would track the supply to maintain the space relative negative pressure.
- If a kiln is provided it shall be located in a separate adjoining room which is independently ventilated to the building exterior using an exhaust fan located outdoors to ensure all portions of the exhaust duct system is kept under negative pressure.
- The fan shall be adequately sized to remove the heat generated by the kiln as well as any potential odours and fumes.
- In addition, the kiln should be connected to a ducted independent exhaust system to further remove potential fumes directly from the kiln and protect occupants near the kiln.
- The actual specific use of the art room shall be determined early in the design process to ensure any ventilation requirements such as duct collection are included.

## 6.6 Corridors

- The use of a ceiling plenum return for the majority of the school occupied spaces will ensure the corridors are substantially ventilated without the need to provide actual supply air ventilation.
- Transfer air from classrooms which are generally positively pressurized and adjoining washrooms which are under negative pressure will ensure corridors are well ventilated.
- All lockers located in corridors shall be ventilated using hard duct return connections to plenums located above each locker section.
- The airflows required to ventilate the lockers is low and flow of 1-2 L/s per locker should be targeted to maintain the lockers under a negative pressure.
- The locker design is critical to ensure good cross ventilation through the locker and should only have bottom face grilles in the doors without ventilation grilles located in the top of the door face. The lockers will require openings in the top of the locker which will allow airflow to the plenum above.
- Consider hard ducted returns from several corridor locations.

## 6.7 Fitness, Computer, Distance Education and Server Rooms

- The designer shall determine the cooling loads associated with the specific computer rooms in the school.
- Fitness rooms, computer rooms, distance learning spaces or server rooms shall have mechanical cooling sized to meet the calculated cooling loads.
- For schools that do not have systems capable of providing central based air conditioning, the preferred method of cooling for spaces having a cooling load of 3 tons or greater would be a packaged rooftop air conditioner or split system. Fresh air should not be provided using this unit but rather originate from the central school heat recovery unit. Either system should permit low ambient operation.
- Small spaces having lower than 3 ton cooling loads should have mini-split units provided to maintain space conditions. These units would also require low ambient kits with wind baffles to allow cooling operation in winter conditions.
- In addition, free economizer cooling should not be provided as this would have a negative impact on space humidity. Instead low ambient cooling options should be incorporated in the unit and mechanical cooling only should be employed.

## 6.8 Classrooms

- All classrooms shall have dedicated ventilation supply from the central heat recovery system.
- In the case of a geothermal heat pump distributed system, the fresh air would be provided to the heat pump return side for distribution to the classroom via the heat pump supply ducting.
- In the case of an electrically heated school, the fresh air would be supplied directly to the classroom from a central heat recovery unit with airflows sized to meet ASHREA 62.1 latest edition.
- All supply grilles or diffusers are to be selected to achieve adequate throw distances to cover the entire floor area while having low noise levels.

- Grilles should be selected with NC levels below the NC rating of the room to ensure generated noise is minimized. Return transfer ducts with acoustic linings and a minimum of one 90° elbow should be provided to complete the return air path to the corridor ceiling and limit noise transfer.
- Transfer ducts should be sized with low velocities to ensure minimum static pressure drops thus promoting air flow.
- Kindergarten classrooms shall have an in-floor heated area of 3.0m x 2.4m with the long (3.0m) side centered on the interactive white board, and offset from the wall or interactive white board by 2m. This allows the teacher to hold floor sessions and still make use of the interactive white board if needed in the session.
- Exact location should be coordinated with the architect.
- A contrasting floor finish color or border shall be used to show the heated area.

## 6.9 Cafeteria

- The ventilation of this space must be sized to accommodate the short term high occupancy levels but in case of a demand controlled ventilation system, the CO2 controlled ventilation air should be designed to vary airflows based on CO2 levels.
- Due to the potential for odours, the return from this space should be hard duct and not plenum returned with the space being designed to operate under slightly negative pressure.

## 6.10 Kitchen

- A kitchen that is used to prepare food for a cafeteria shall have a NFPA 96 grease exhaust system provided regardless of whether residential or commercial cooking appliances are used.
- A dedicated make-up air system is to be provided consisting of supply fan and heating coil to ensure make-up air is adequately provided to offset the air being exhausted.
- In combustible construction and where the grease duct penetrates a fire separation the grease duct shall have '0' clearance ULC approved grease duct wrap.
- The wall construction at the grease hood location shall be coordinated with the architect and be adjusted to ensure this wall is non-combustible or limited combustible with acceptable clearance as defined by NFPA 96.
- The heat associated with cooking process will result in high space temperatures requiring the inclusion of air conditioning in this space. The cooling requirement shall be determined based on the anticipated heat gain loads of the space and desired operating conditions.
- The kitchen should also be ventilated from the central heat recovery unit as the space would be occupied when the hood is not operating.
- As with the other odour generating spaces the kitchen shall have a hard duct return to the HRV to ensure this space is under negative pressure.

## 6.11 Office Spaces

- Office spaces will generally follow the same guidelines as classrooms.

## 6.12 Washrooms / Change Rooms

- Washroom exhaust must be directed to the heat recovery unit to recover the heat contained in the air prior to exhausting to the building exterior. Ensure zero cross contamination.
- Generally washroom exhaust should be constant during occupied periods, therefore in a variable volume system this exhaust should be kept consistent even when the central HRV is varying overall airflows.

## 7 System Analysis (Energy Models)

### 7.1 Energy Modelling

Energy analysis is an important tool in the design process whereby system decisions are often based on results from energy modelling. The accuracy of the model is of key importance since modelling inaccuracy may result in poor decision making.

The use of energy analysis software to predict building performance must be incorporated on all school projects. The software used must be hourly based using historical climatic averages with some examples of this software being Carrier HAP, eQuest and Trane Trace 700. The software must be approved by the CaGBC for use in LEED modelling.

The energy modelling should provide realistic energy predictions which will be used to evaluate system options and provide system sizing data. The importance of accurate energy modelling cannot be understated as the economic analysis outcome is heavily weighted on the predicted energy use. The difficulty in providing accurate models are often due to the assumptions which must be incorporated into the model such as plug loads, occupancy schedules, infiltration estimates, etc. To ensure consistency in the modelling results the following values should be used during the completion of energy models:

Plug loads	15 kWh per m <sup>2</sup> /year
Domestic hot water use	High school: 5 kWh per m <sup>2</sup> /year Elementary/Primary school: 3 kWh per m <sup>2</sup> /year
Infiltration	0.41 L/s per m <sup>2</sup> exterior wall (all spaces except vestibules) 5 ACH (vestibules)
School occupancy	8AM to 5PM Sept 1 to June 30
Gym occupancy	Normally single class size with a full school assembly once every two weeks for 2 hours.
Night setback temperature	15°C (Heating setpoint)
Duct leakage	2%

The models shall be developed using the actual design lighting loads in each space instead of average W/m<sup>2</sup>, using actual R-values for architectural wall and roof construction elements, as well as U-values and shading coefficients for window elements. In addition, the modelling shall reflect the actual fan/pump sizes as well as the actual efficiency of heat recovery components included in the design.



## **APPENDIX E – BIKE RACK DETAILS**

# BIKE RACK DETAIL

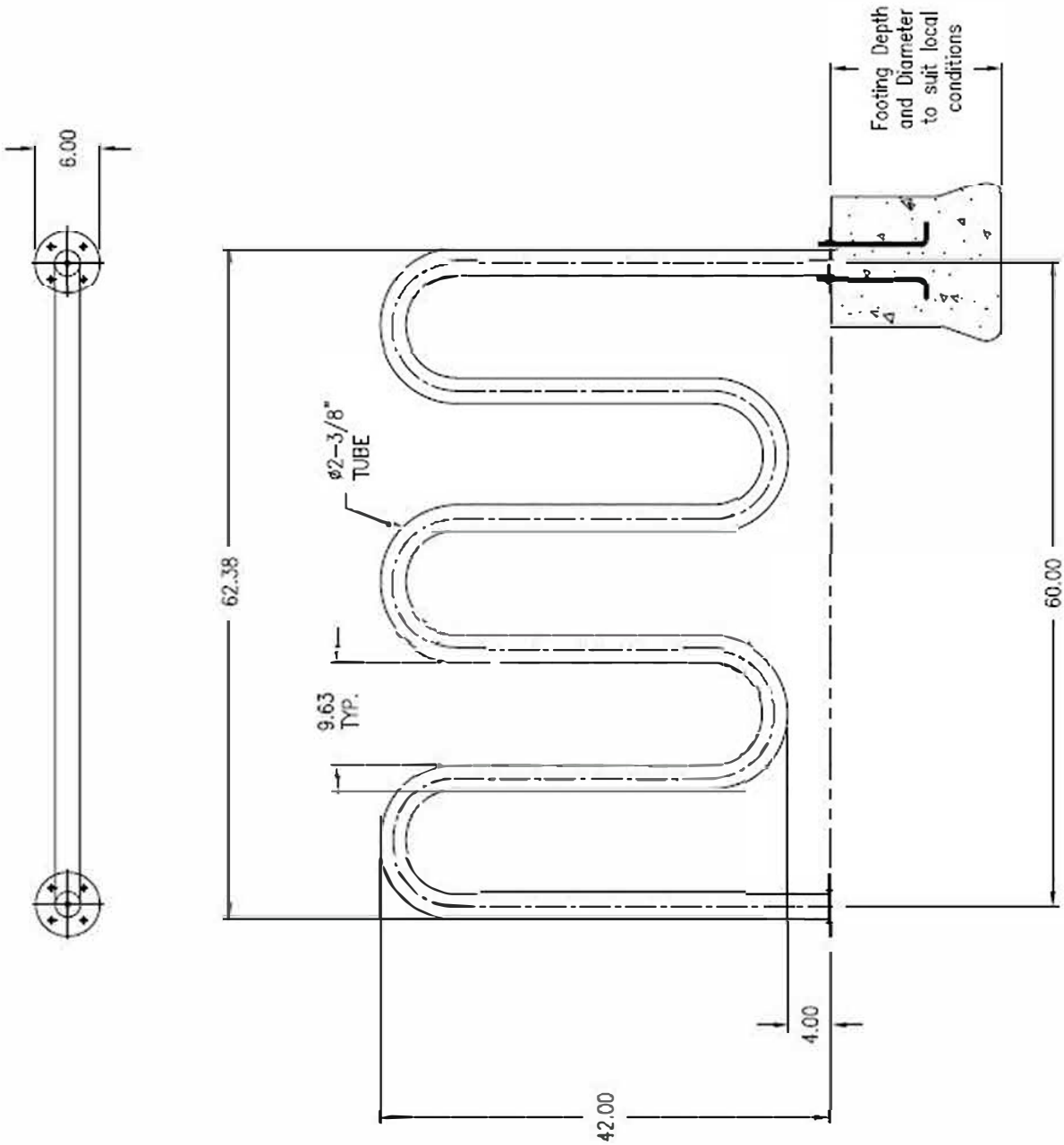

**WAVE STYLE BIKE RACK  
SINGLE SECTION SHOWN; EXPAND TO MEET REQUIREMENTS**

**APPENDIX F – FIBA BASKETBALL COURT**

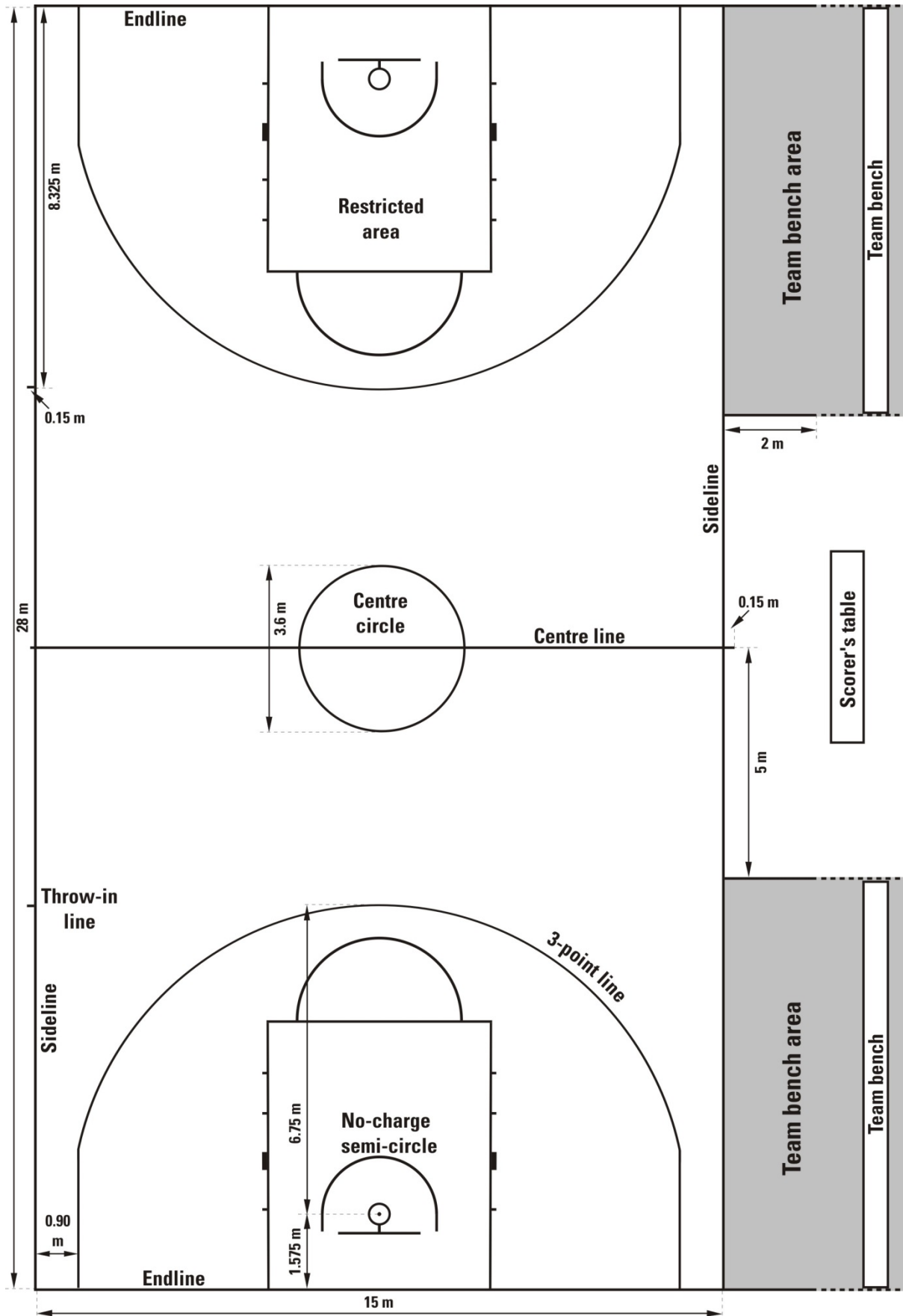

**Diagram 1 Full size playing court**

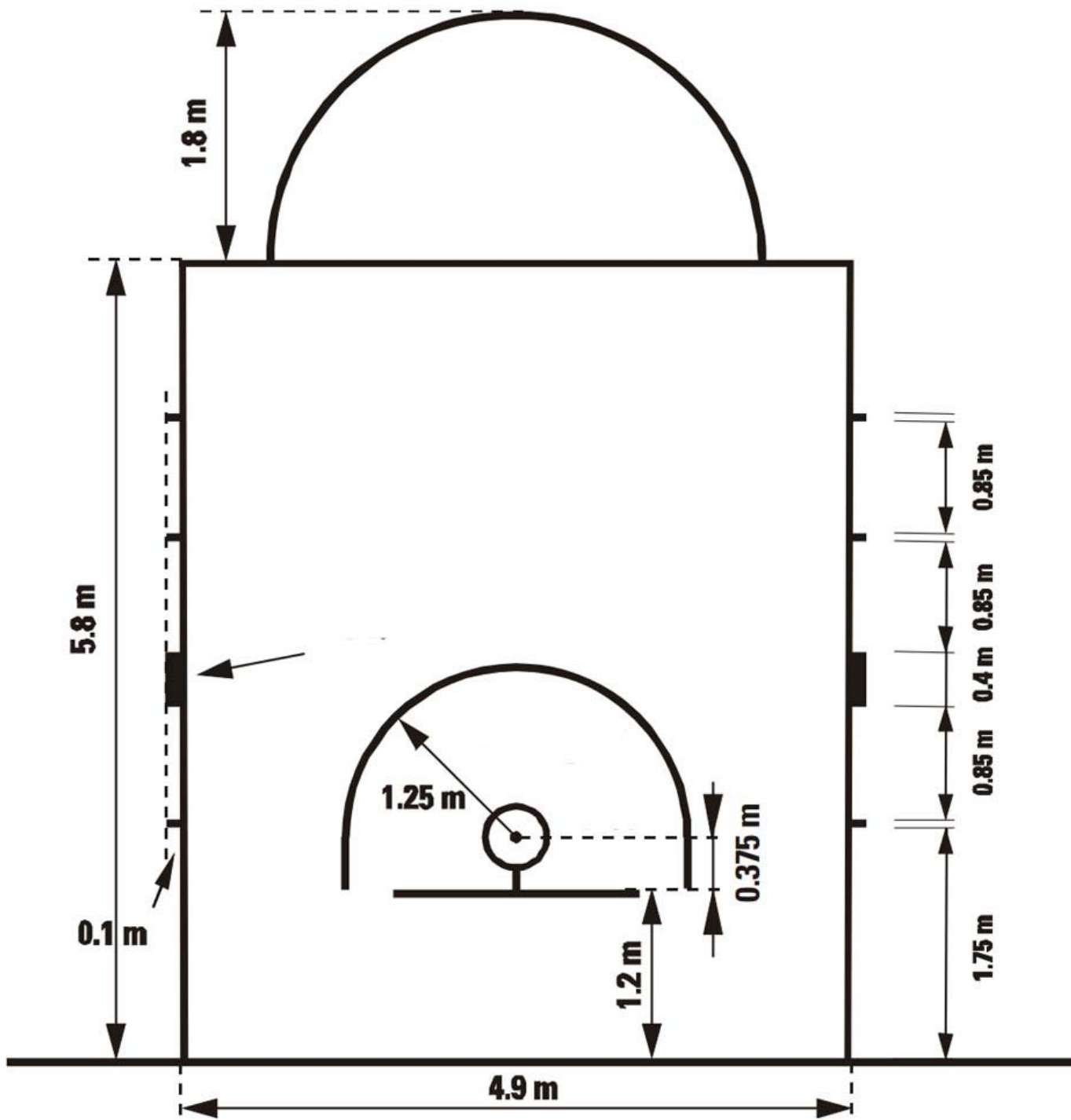

## **APPENDIX G – SOCCER NET ANCHORING GUIDELINES**

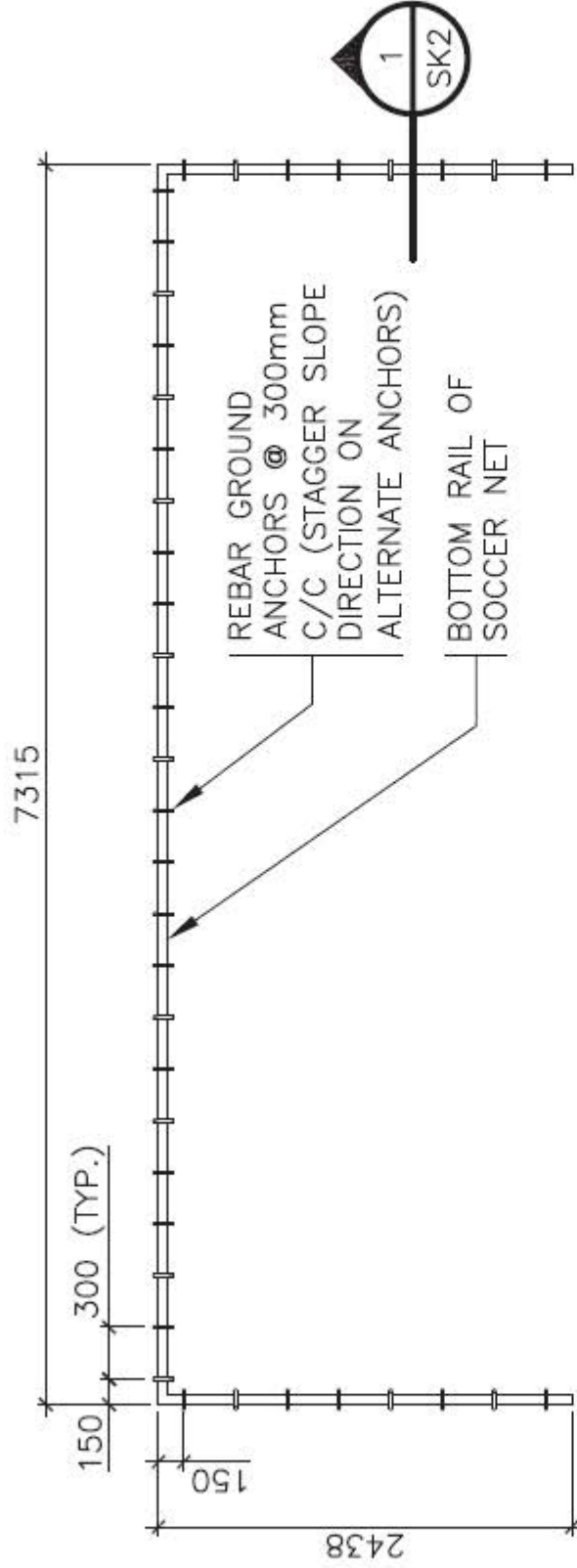

NOTE: OVERALL SIZE OF NET MAY VARY

# PLAN -- ANCHOR IN GRAVEL--TYPE SOIL

SCALE : 1:50



PROJECT TITLE		PROJECT NO.	
SOCCER NET ANCHORING DETAILS		12140	
DRAWING TITLE		DRAWING NO.	
PLAN		SK1	
DESIGNED		REVISION	
APPROVED			
SCALE 1:50			
DATE			

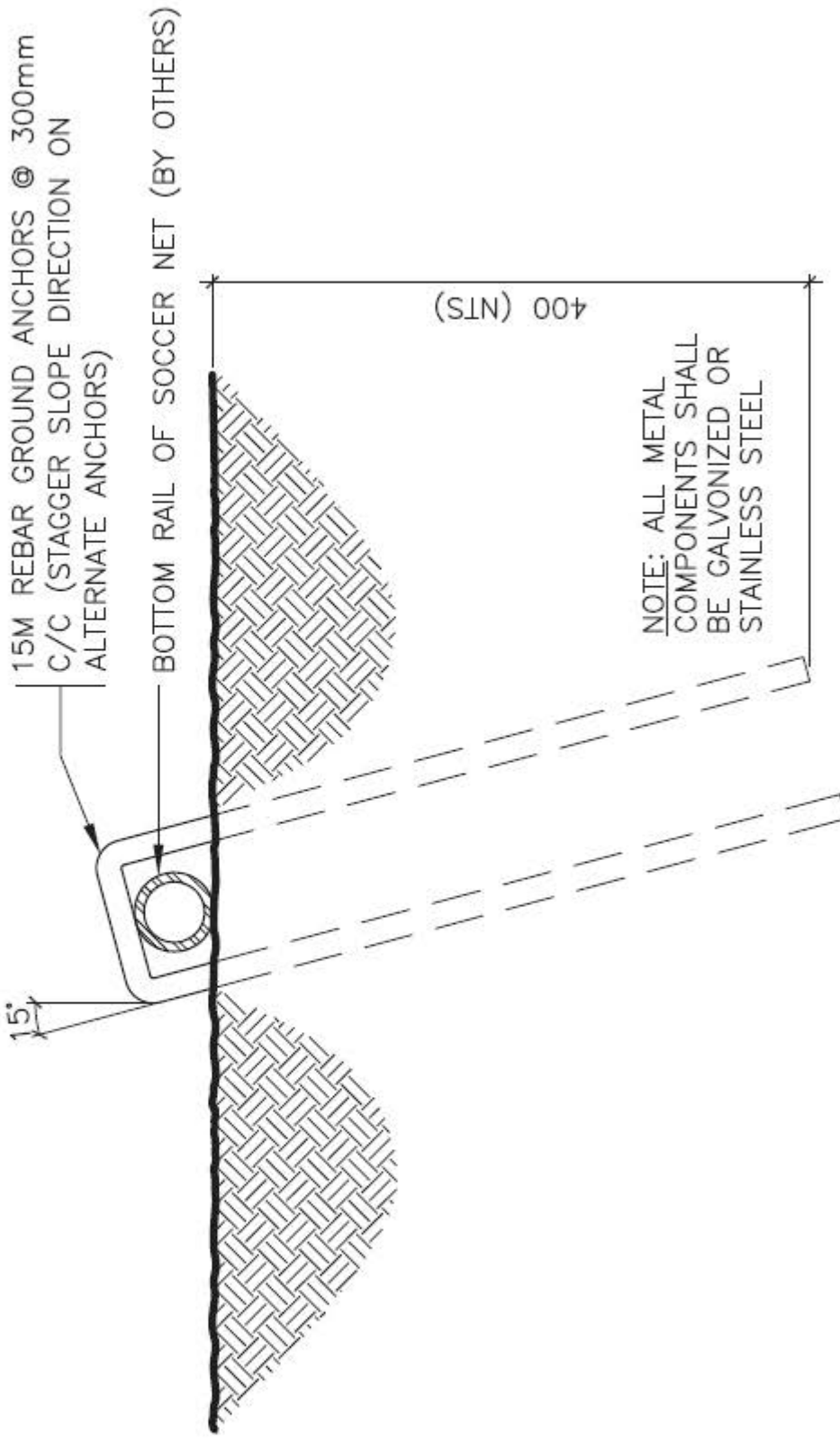

**SECTION - ANCHOR IN GRAVEL-TYPE SOIL** 1  
SK2

SCALE : 1:5



PROJECT TITLE <b>SOCCER NET ANCHORING DETAILS</b>		PROJECT NO. <b>12140</b>
DRAWING TITLE <b>SECTION</b>		DRAWING NO. <b>SK2</b>
DRAWN	DESIGNED	
CHECKED	APPROVED	
SCALE 1:5	DATE	REVISION



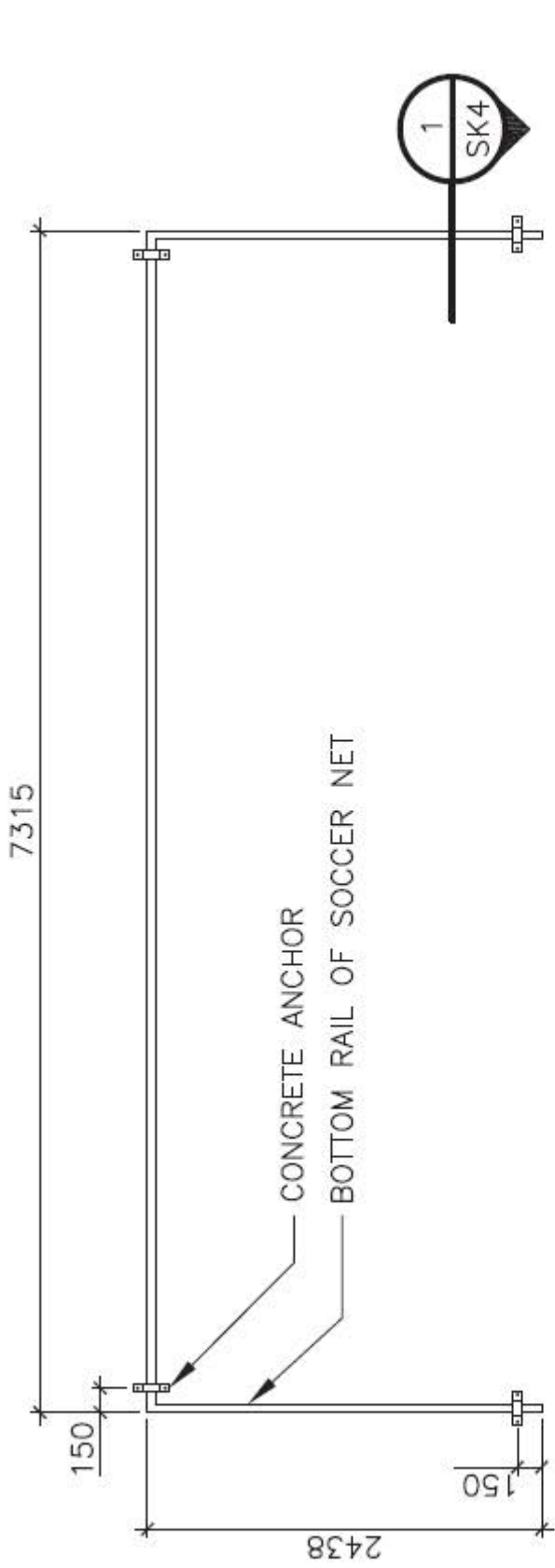

NOTE: OVERALL SIZE OF NET MAY VARY

**PLAN -- ANCHOR IN SOFT GROUND  
(1 METRE MIN. TO BEDROCK)**

SCALE : 1:50



1  
SK3

PROJECT TITLE <b>SOCCER NET ANCHORING DETAILS</b>		PROJECT NO. 12140		
		DRAWING NO. <b>SK3</b>		
DRAWN	DESIGNED	DRAWING TITLE <b>PLAN</b>		
	CHECKED			APPROVED
	SCALE			DATE
REVISION				



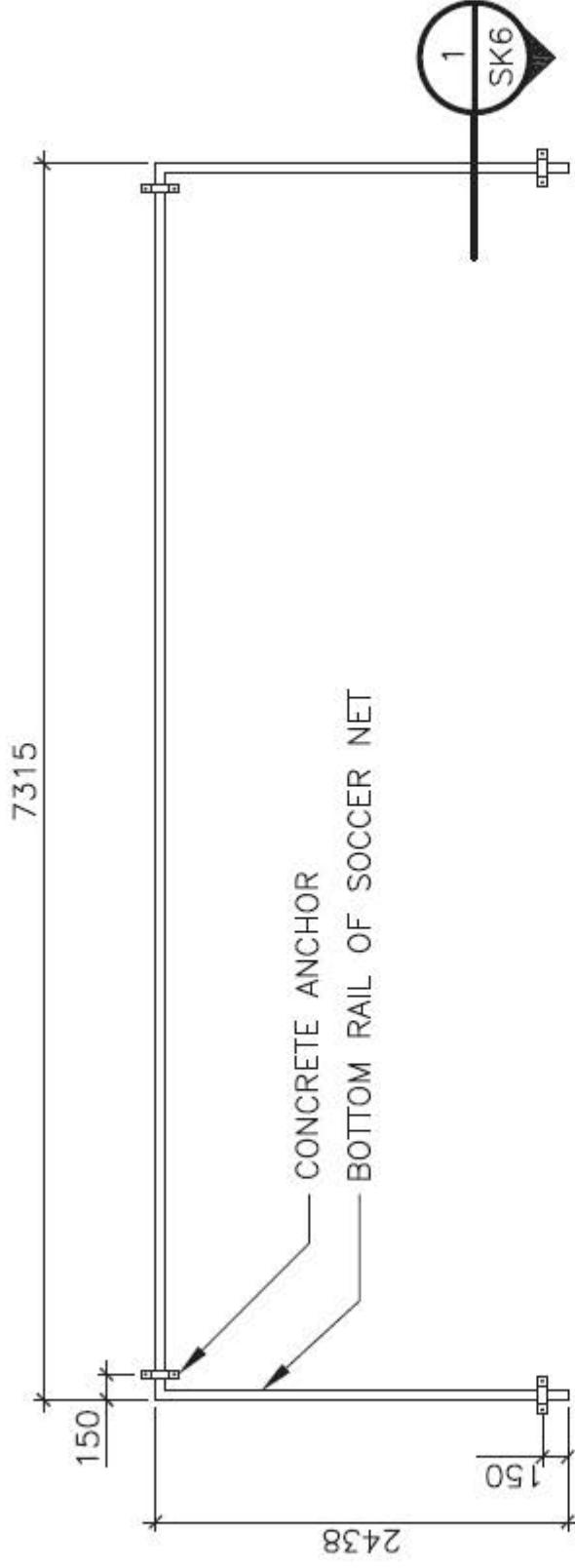

NOTE: OVERALL SIZE OF NET MAY VARY

**PLAN - ANCHOR IN SOFT GROUND  
(LESS THAN 1 METRE TO BEDROCK)**

1 SK5

SCALE : 1:50



PROJECT TITLE		PROJECT NO.	
SOCCER NET ANCHORING DETAILS		12140	
DRAWING TITLE		DRAWING NO.	
PLAN		SK5	
DRAWN		REVISION	
DESIGNED			
CHECKED			
APPROVED			
SCALE 1:50			
DATE			





# Soccer Goal Safety

SECOND EDITION



In an effort to provide continuing goal safety education to the soccer community at large, Kwik Goal has produced the following Soccer Goal Safety Reminder. This guide is based, in large part, on the CPSC document "Guidelines For Movable Soccer Goal Safety."

We encourage the many volunteer coaches, administrators, and parents to use this pamphlet as a reminder to practice pre-match safety inspections. We also encourage all organizations that own or use soccer goals to implement a post-match safety plan to ensure that goals are secure after organized play has concluded.

Most importantly, take a few minutes to discuss this issue with your players. All age groups need to understand the dangers of climbing on any soccer goal.

Please visit:

[www.kwikgoal.com/safetyfirst](http://www.kwikgoal.com/safetyfirst) for more information on soccer goal safety and for soccer goal safety stickers.

**Duplication of this document is encouraged.**



This document is intended to provide basic soccer goal safety information and soccer goal-purchasing guidance and is not all-inclusive. While following the concepts in this booklet will ensure that your soccer goal is safer, it may not prevent all accidents.

## MYTH vs. FACT

**MYTH:** The majority of soccer goal related injuries occur during matches or training.

**FACT:** Most soccer goal related injuries occur when organized soccer play is over. Injuries occur either during the transport of goals, when goals are being used for unapproved purposes, or during pick-up soccer.

**MYTH:** Heavier soccer goals need not be anchored because of the inherent difficulty in moving them.

**FACT:** Any unanchored goal can be tipped with catastrophic results.

**MYTH:** Homemade goals that match manufacturer's designs or styles will act as a suitable replacement for professionally manufactured goals.

**FACT:** The CPSC reports a large majority of goals involved in fatal or serious tip-over accidents involve "homemade" goals that have been made by shop classes, custodial staff, or local welders who are not fully aware of proper anchoring techniques and safe counterbalancing goal designs.

**MYTH:** Soccer goals will not tip unless moved or climbed upon.

**FACT:** Unanchored, portable, lightweight goals are capable of tipping during high wind conditions, especially with nets affixed to the frame. All goals should be anchored when they are in an upright position.

**MYTH:** Once a goal is anchored, it is considered secure.

**FACT:** Unless a goal is anchored in a permanent/semi-permanent manner (ground sleeves or anchors in cement), it should be secured after soccer play is finished by locking goals face to face, locking goals to a permanent structure, or in some cases placing goals "face-down" on to the ground.

**MYTH:** Padded goals will reduce injury when a goal tips over.

**FACT:** Padding will not protect a person from injury when a goal tips over.

## PRE-MATCH SOCCER GOAL CHECKLIST

- | YES                      | NO                       |  |
|--------------------------|--------------------------|--|
| <input type="checkbox"/> | <input type="checkbox"/> | Are anchors in place and secured properly to the goal and ground surface?    |
| <input type="checkbox"/> | <input type="checkbox"/> | If anchor bags are being used, are they in good condition?                   |
| <input type="checkbox"/> | <input type="checkbox"/> | Are anchor bags adequately filled with aggregate?                            |
| <input type="checkbox"/> | <input type="checkbox"/> | Are anchor bags placed over the base of the goal frames at the back corners? |
| <input type="checkbox"/> | <input type="checkbox"/> | Is all connecting hardware, such as nuts and bolts, in place and secure?     |
| <input type="checkbox"/> | <input type="checkbox"/> | Has the structural integrity of the goal been compromised?                   |
| <input type="checkbox"/> | <input type="checkbox"/> | Are welds cracked?   |
| <input type="checkbox"/> | <input type="checkbox"/> | Are corner joints secure?  |
| <input type="checkbox"/> | <input type="checkbox"/> | Is the goal on a level surface?  |
| <input type="checkbox"/> | <input type="checkbox"/> | Are the goal nets attached properly to the goal frame?                       |
| <input type="checkbox"/> | <input type="checkbox"/> | Do sharp edges exist in any part of the goal and net attachment system?      |
| <input type="checkbox"/> | <input type="checkbox"/> | Do the nets have large holes or tears?                                       |

## POST-MATCH SOCCER GOAL SUGGESTIONS

If goals are to remain in the upright position, make sure they are secured with cement based ground anchors or ground sleeves.

If goals are anchored with portable style anchors, goals should be stored by being chained together face-to-face, chained to a permanent structure, or in some cases placed in a face down position.

- **Remove the net when the goal is not in use.**
- **Make sure that all connecting hardware is in place and secure.**
- **Check the structural integrity of the goal.**
- **Never allow anyone to climb on the goals.**
- **If goals are to be moved, exercise extreme caution and provide adequate manpower to move the goals.**
- **Check condition of warning labels.**

## POST-SEASON SUGGESTIONS

When the soccer season is complete, consider fully disassembling goals and storing them in the proper facilities.



# ANCHORING SYSTEMS

Anchors that are installed into concrete (semi-permanent anchors) are the safest overall anchoring option because they will function properly in all soil conditions.

If the use of a semi-permanent anchor is not feasible, it's critical that soil conditions are identified when choosing portable type anchors.

## Semi-Permanent Ground Anchors

Soccer goal anchors are considered semi-permanent when the base of the anchor is cemented into the ground. The goal is then placed in position according to the system, and then either a bolt or a leash system is used to secure the goal to the anchor.

Another type of semi-permanent anchor is a ground sleeve that is cemented into the ground. An extended goal post will then slide into the sleeve, anchoring the goal itself into the ground.

## Portable Ground Anchors (Below Ground)

When deciding on a portable ground anchor, it is important to know the characteristics of the soil where the soccer goals are located. The quality of support offered by an anchor peg or auger anchor will be determined by the one to two foot layer of soil under the top soil called the sub-soil.

### Clay soil

Ground anchor pegs are the best portable anchoring option for goals being anchored into soil that is considered hard or clay based. A 12" anchor peg would be suitable because of the compaction and heavy qualities of this type of soil.

### Loam soil

Loam soils have a more even dispersion of clay, sand and silt and therefore require a more aggressive portable type of anchor. A 16" anchor peg would be best in this soil condition.

### Sandy soil

The cork-screw design of an auger anchor will be able to grip the sandy soils effectively.

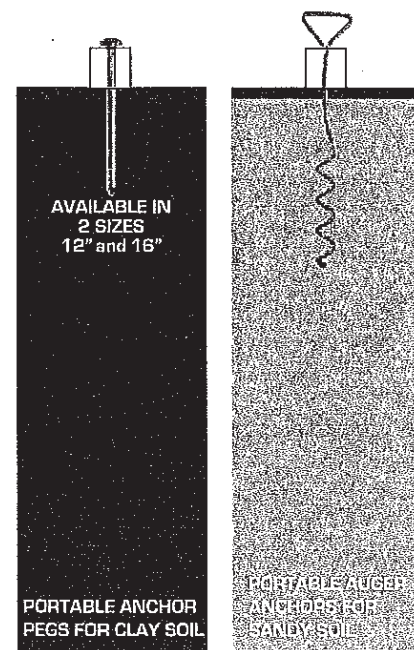
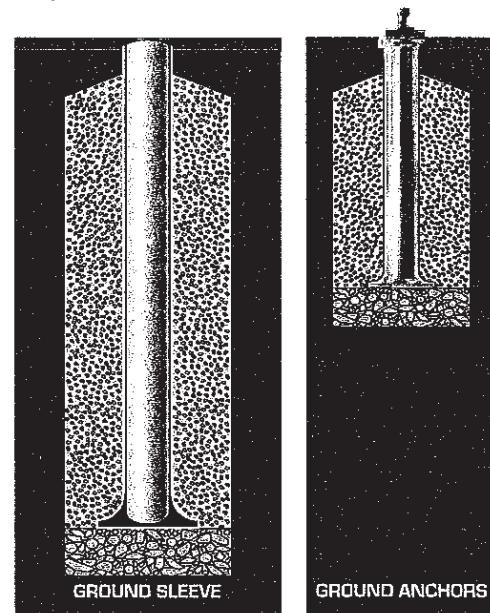

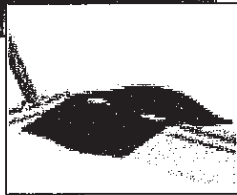

## **Portable Ground Anchors (Above Ground/Artificial Surfaces)**

The two main options for anchoring soccer goals on top of the playing surface are anchor bags or anchor weights.

The minimum weight for anchoring specific models and sizes of soccer goals will vary. Always check with the goal manufacturer for the proper above ground anchor weight recommendations for your specific goal.

When using anchor bags or anchor weights, please note that the anchors should be placed at the back corners of the goal at the frame base and back bar.

Also, a periodic quality check of the above ground anchors is advised. Torn or ripped bags will lose aggregate over time. Anchors in disrepair may also damage artificial surfaces.

## **Replacement Anchors**

A soccer goal frame and its anchors function as one system. Goal design, material and weight are all factors that manufacturers will take into account when designing anchors. Anchors made for a specific manufacturer's goal model may not be suitable for other goal types and goal makes. If replacement anchors are needed for an existing goal, contact the original manufacturer of the goal frame.

## **Installing Anchors Before The Turf**

We recommend that you discuss anchor installation with the turf installer during the planning stages of the project. It may be possible to have semi-permanent style anchors installed prior to the installation of the playing surface.

**All soccer goal anchors should be inspected for damage and installation integrity on a regular basis. Any damaged anchor should be replaced immediately.**

## SOCCER GOAL NET SAFETY

There is always a potential danger for unattended children and players to see a soccer goal as something to climb. Beyond safe goal anchoring practices, it is also recommended that soccer nets manufactured to minimize unsafe climbing situations be installed. Smaller mesh netting helps prevent entrapment and discourages climbing and other misuse that can lead to serious injury.

Most U.S. manufacturers provide netting with 140mm mesh sizes. Installing nets with 120mm mesh is highly recommended in order to reduce potential entrapment situations.

A second net style that would provide an even better safeguard for misuse is a net made with 2" size mesh. Toeholds and footholds that would exist in larger mesh netting are essentially eliminated with two inch mesh nets.

Both the ASTM in the U.S. and the English FA provide guidelines that highly recommend soccer goal net mesh measurements not exceed 4.72 inches (120mm) in width.

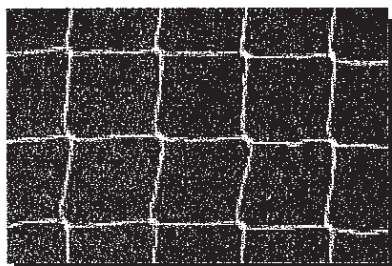

120 mm Mesh

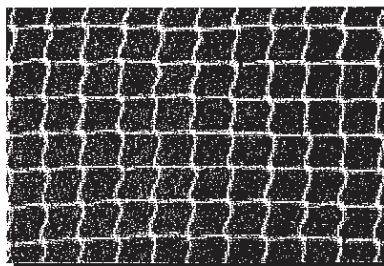

2" Mesh

## REFERENCES

For further information on soccer goal safety and soccer goal performance standards, please reference the following resources:

**U.S. CONSUMER PRODUCT SAFETY COMMISSION:** [www.cpsc.gov](http://www.cpsc.gov)

Document numbers:

326 Guidelines for Moveable Soccer Goal Safety

5118 Movable Soccer Goals Can Fall Over On Children

**ASTM:** [www.astm.org](http://www.astm.org)

F1938-98 Guide for Safe Use of Movable Soccer Goals

F2056-00 Safety and Performance Specification for Soccer

**THE FA:** [www.thefa.com](http://www.thefa.com)

Goals for Football Technical Details

Goals for Football Guidance Notes



## SOCCER GOAL PURCHASING GUIDELINE

More and more clubs and schools are becoming aware of the dangers of owning and using homemade or dilapidated soccer goals. Purchasing safe and reliable replacement goals can be daunting, especially when most goal models look alike in print or on the internet.

The following Soccer Goal Buying Guide Checklist focuses on the three key areas soccer goal purchasers should investigate when researching and comparing the qualities and specifications of soccer goals: design and construction; ease of assembly; and, of course, anchoring systems.

### Design and Construction

Poorly designed goals provide hidden dangers to the teams using them. Goal frame design redundancies provide built in safeguards should pre-match and post-match inspections be overlooked.

The questions posed below may reveal shortcuts taken in the product design and manufacturing processes.

- | YES                      | NO                       |  |
|--------------------------|--------------------------|--|
| <input type="checkbox"/> | <input type="checkbox"/> | 1. Does the goal frame or net attachment systems have sharp edges, particularly near the playing field?  |
| <input type="checkbox"/> | <input type="checkbox"/> | 2. Does the goal frame or net attachment system pose child entrapment, protrusion or pinch point dangers?  |
| <input type="checkbox"/> | <input type="checkbox"/> | 3. Does the goal post design allow for easy pre-match inspection by officials or coaches?  |
| <input type="checkbox"/> | <input type="checkbox"/> | 4. Does each goal frame attachment point have multiple bolts for safety redundancy?  |
| <input type="checkbox"/> | <input type="checkbox"/> | 5. Is there at least three inches of frame material overlap with all telescoping parts for safety redundancy?  |
| <input type="checkbox"/> | <input type="checkbox"/> | 6. Are all goal parts through bolted to ensure goal frame parts stay connected even if fasteners become loose?   |
| <input type="checkbox"/> | <input type="checkbox"/> | 7. Is a quality, durable finish like powder coating used?  |
| <input type="checkbox"/> | <input type="checkbox"/> | 8. If an artificial surface is utilized, is the goal frame's base smooth and free of edges that might damage the playing field?                        |
| <input type="checkbox"/> | <input type="checkbox"/> | 9. Are wheel options available for easy goal frame movement and can they be engaged simply without the continual removal or replacement of components? |
| <input type="checkbox"/> | <input type="checkbox"/> | 10. Are goal frame ends open or uncovered?   |

## Ease Of Assembly

Shortcuts are taken when the goal assembly process is difficult and lengthy. For complexes with many fields, additional on-field construction steps (like drilling) limits the likelihood that mixed goal parts will easily fit together when goals are reassembled the following season.

- | YES                      | NO                       |   |
|--------------------------|--------------------------|---|
| <input type="checkbox"/> | <input type="checkbox"/> | 1. Are comprehensive, professionally rendered instructions provided with the goal?  |
| <input type="checkbox"/> | <input type="checkbox"/> | 2. Can the goal be assembled with simple hand tools as opposed to power tools or tools requiring special knowledge?   |
| <input type="checkbox"/> | <input type="checkbox"/> | 3. Are goal safety warning labels included and affixed to the goal by the manufacturer ( instead of the customer) prior to shipping?                              |
| <input type="checkbox"/> | <input type="checkbox"/> | 4. Does the manufacturer ask the customer to perform multiple construction steps like drilling holes or connecting many small components at the time of assembly? |

## Anchoring

An "all-soil" condition anchor should be included with your goal at the time of purchase. Portable or above-ground anchors should be purchased additionally according to the soil conditions of the playing field and the overall usage logistics of the facility (i.e. multiple sports).

- | YES                      | NO                       |   |
|--------------------------|--------------------------|---|
| <input type="checkbox"/> | <input type="checkbox"/> | 1. Will the anchoring system included with the goal function in all soil conditions per ASTM standards?               |
| <input type="checkbox"/> | <input type="checkbox"/> | 2. Do assembly instructions include directions on how to test the goal after installation to ensure proper anchoring? |
| <input type="checkbox"/> | <input type="checkbox"/> | 3. Can additional types of anchors be used within the goal's design?  |
| <input type="checkbox"/> | <input type="checkbox"/> | 4. Has the manufacturer tested the goal's design against ASTM and FA Standards?                                       |







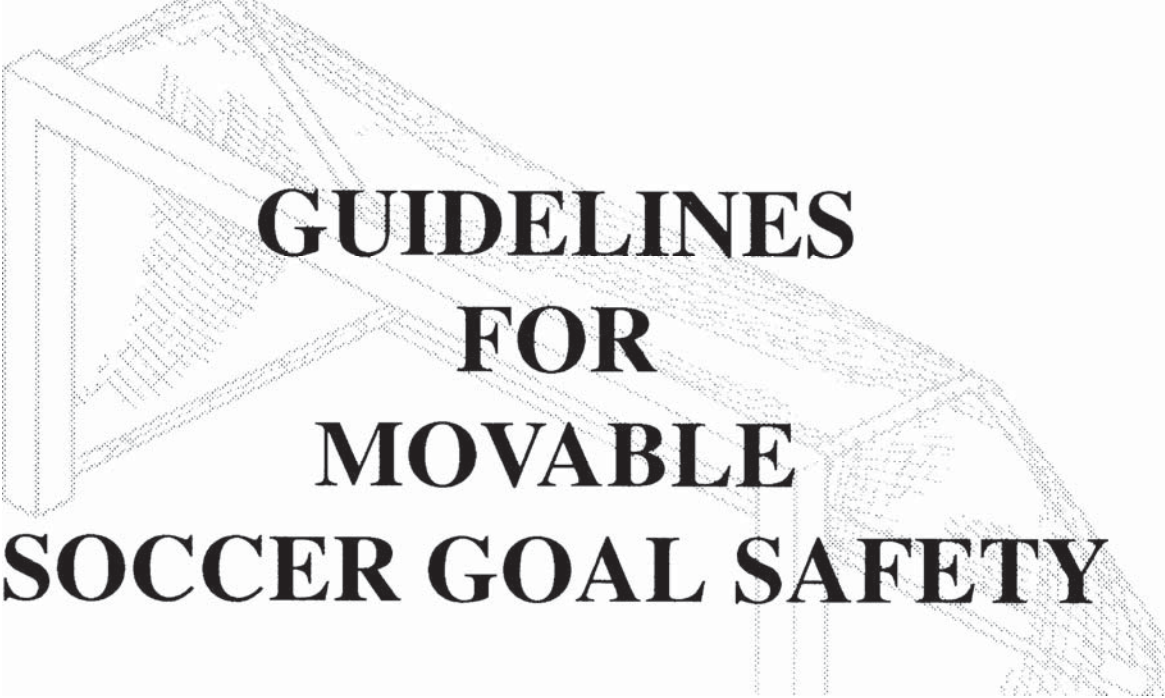

A faint, dotted-line illustration of a soccer goal is positioned in the background, behind the title text.

# **GUIDELINES FOR MOVABLE SOCCER GOAL SAFETY**

January 1995  
U.S. Consumer Product Safety Commission  
Washington, D.C. 20207

## CONTENTS

1. Introduction .....	1
2. Soccer Goal Injuries .....	1-2
3. Rules of Soccer .....	2
4. Design/Construction Guidelines .....	3
5. Anchoring/Securing/Counterweighting Guidelines .....	4-7
6. Goal Storage Guidelines .....	7-8
7. Conclusions .....	8

## APPENDICES

Appendix A - List of Soccer Organizations .....	9
Appendix B - For Further Information.....	9
Appendix C - Warning Labels .....	10



## 1. Introduction

This handbook presents guidelines for the installation, use and storage of full-size or nearly full-size movable soccer goals. The U.S. Consumer Product Safety Commission (CPSC) believes these guidelines can help prevent deaths and serious injuries resulting from soccer goal tipover. Publication of the handbook is intended to promote greater safety awareness among those who purchase, install, use, and maintain movable soccer goals.

These guidelines are intended for use by parks and recreation personnel, school officials, sports equipment purchasers, parents, coaches, and any other members of the general public concerned with soccer goal safety.

These guidelines are intended to address the risk of movable soccer goal tipover. They are not a CPSC standard, nor are they mandatory requirements. Therefore, the Commission does not endorse them as the sole method to minimize injuries associated with soccer goals.

## 2. Soccer Goal Injuries and Deaths

According to the 1994 National Soccer Participation Survey (Soccer Industry Council of America), over 16 million persons in the United States play soccer at least once a year. Seventy-four percent (over 12 million) of these persons are under the age of 18. Soccer ranks fourth in participation for those under 18, following basketball, volleyball, and softball and well ahead of baseball, which has an annual participation of 9.7 million.

There are approximately 225,000 to 500,000” soccer goals in the United States. Many of these soccer goals are unsafe because they are unstable and are either unanchored or not properly anchored or counter-balanced. These movable soccer goals pose an unnecessary risk of tipover to children who climb on goals (or nets) or hang from the crossbar.

The CPSC knows of four deaths in 1990 alone and At least 21 deaths during the past 16 years (1979-1994) associated with movable soccer goals. In addition, an estimated 120 injuries involving falling goals were treated each year in U.S. hospital emergency rooms during the period 1989 through 1993. Many of the serious incidents occurred when the soccer goals tipped over onto the victim. Almost all of the goals involved in these tipovers appeared to be **“home-made”** by high school shop classes, custodial members, or local welders, not professionally manufactured. These **“home-made”** goals are often very heavy and unstable.

The majority of movable soccer goals are constructed of metal, typically weighing 150-500” pounds. The serious injuries and deaths are a result of blunt force trauma to the head, neck, chest, and limbs of the victims. In most cases this occurred when the goal tipped or was accidentally tipped onto the victim. In one case an 8-year-old child was fatally injured when the movable soccer goal he was climbing tipped over and struck him on the head. In another case, a 20-year-old male died from a massive head trauma when he pulled a goal down on himself while attempting to do

chin-ups. In a third case, while attempting to tighten a net to its goal post, the victim's father lifted the back base of the goal causing it to tip over striking his 3-year-old child on the head, causing a fatal injury.

High winds can also cause movable soccer goals to fall over. For example, a 9-year-old was fatally injured when a goal was tipped over by a gust of wind. In another incident, a 19-year-old goalie suffered stress fractures to both legs when the soccer goal was blown on top of her.

### **3. Rules of Soccer**

From the Federation of International De Football Associations' (FIFA) *Laws of the Game, Guide for Referees, July 1993.*

“Goal-posts and cross-bars must be made of wood, metal, or other approved material as decided from time to time by the International Football Association Board. They may be square, rectangular, round, half round, or elliptical in shape.”

“Goal-posts and cross-bars made of other materials and in other shapes are not permitted. The goal-posts must be white in color.”

“The width and depth of the cross-bar shall not exceed 5 inches(12 cm).”

From the National Federation of State High School Associations' (NFSHSA) 1994-95 *National Federation Edition-Soccer Rules Book.*

“They shall consist of 2 upright (posts) 4 inches but not more than 5 inches (0.10m by 0. 12m)...the tops of the posts shall be joined by a 4 inches but not more than 5 inches (0. 10m by 0.12m) horizontal crossbar...”

From the National Collegiate Athletic Associations' (NCAA) *Rules for Soccer.*

“...and shall consist of two wooden or metal posts, . . .the width or diameter of the goal-posts and crossbar shall not be less than 4 inches (10.16 cm) nor more than 5 inches (12.7 cm).”

## 4. Design/Construction Guidelines

While a movable soccer goal appears to be a simple structure, a correctly designed goal is carefully constructed with counterbalancing measures incorporated into the product. The common dimensions of a full-size goal are approximately 7.3 m (24 ft.) in width by 2.4 m (8 ft.) in height and 1.8 m (6 ft.) in depth (see Figure 1). The stability of a soccer goal depends on several factors. One effective design alternative uses a counterbalancing strategy by lengthening the overall depth of the goal to effectively place more weight further from the goal's front posts (more weight at the back of the goal). A second design selects lightweight materials for the goal's front posts and crossbar and provides much heavier materials for the rear ground bar and frame members. This tends to counterbalance the forces working to tip the goal forward. Another design uses a heavy rear framework and folds flat when not in use, making the goal much less likely to tip over. Finally, after these various designs are considered, it is imperative that ALL movable soccer goals be anchored firmly in place at all times (see section 5).

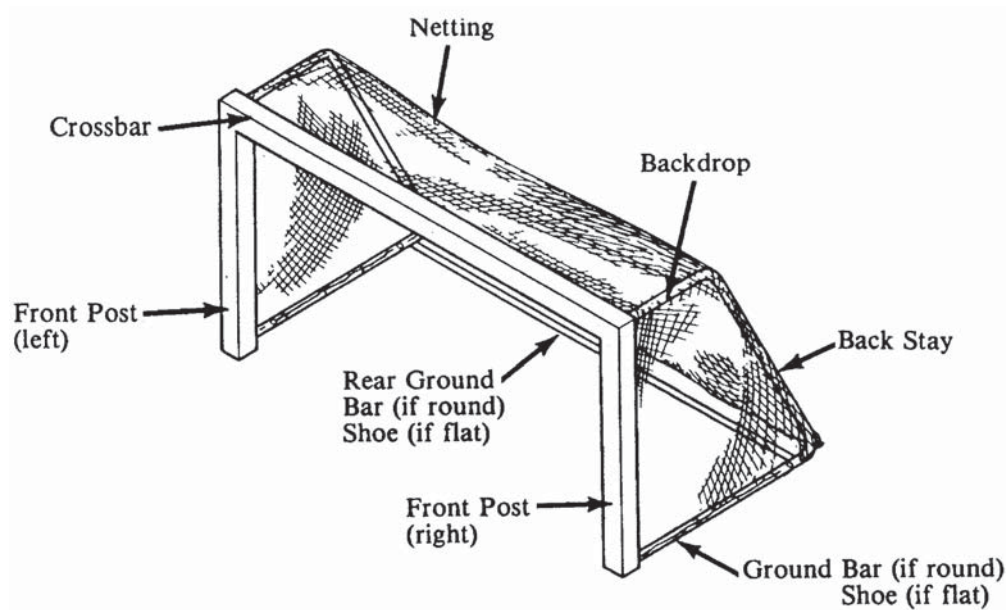
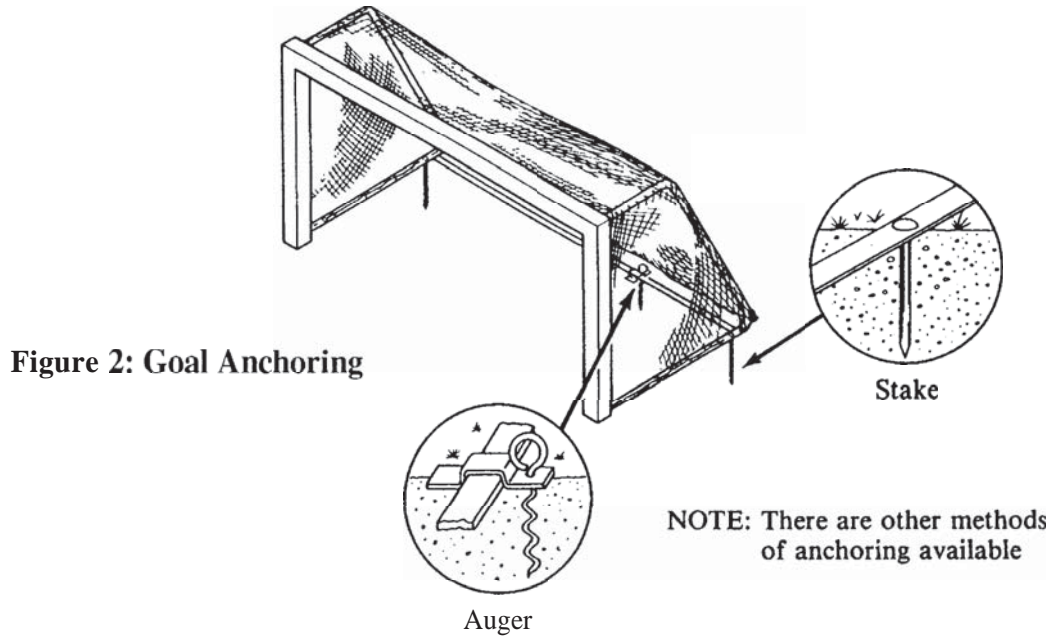

Figure 1: Components of a Movable Soccer Goal

## 5. Anchoring/Securing/Counterweighting Guidelines

A properly anchored/counterweighted movable soccer goal is much less likely to tip over. Remember to secure the goal to the ground (preferably at the rear of the goal), making sure the anchors are flush with the ground and clearly visible. It is **IMPERATIVE** that **ALL** movable soccer goals are always anchored properly (see Figure 2). There are several different ways to secure your soccer goal. The number and type of anchors to be used will depend on a number of factors, such as soil type, soil moisture content, and total goal weight.



### Anchor Types

#### ● Auger style

This style anchor is “helical” shaped and is screwed into the ground. A flange is positioned over the ground shoes (bar) and rear ground shoe (bar) to secure them to the ground. A minimum of two auger-style anchors (one on each side of the goal) are recommended. More may be required, depending on the manufacturer’s specifications, the weight of the goal, and soil conditions.

**Figure 3.1: Auger Style Anchor**



● **Semipermanent**

This anchor type is usually comprised of two or more functional components. The main support requires a permanently secured base that is buried underground. One type (3.2a) of semipermanent anchor connects the underground base to the soccer goal by means of 2 tethers. Another design (3.2b) utilizes a buried anchor tube with a threaded opening at ground level. The goal is positioned over the buried tube and the bolt is passed through the goal ground shoes (bar) and rear ground shoe (bar) and screwed into the threaded hole of the buried tube.

**Figure 3.2a: Semipermanent Anchor**

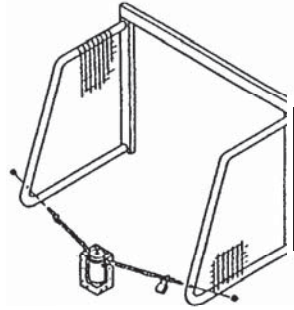

**Figure 3.2b: Semipermanent Anchor**

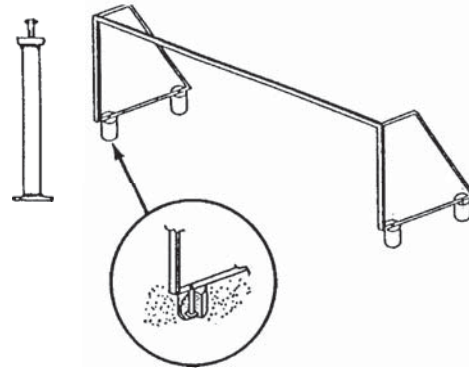

● **Peg or Stake style (varying lengths)**

Typically two to four pegs or stakes are used per goal (more for heavier goals) (Figure 3.3). The normal length of a peg or stake is approximately 10 inches (250mm). Care should be taken when installing pegs or stakes. Pegs or stakes should be driven into the ground with a sledge-hammer as far as possible and at an angle if possible, through available holes in the ground shoes (bar) and rear ground shoe (bar) to secure them to the ground. If the peg or stake is not flush with the ground, it should be clearly visible to persons playing near the soccer goal. Stakes with larger diameters or textured surfaces have greater holding capacity.

**Figure 3.3: Peg or Stake Style Anchor**

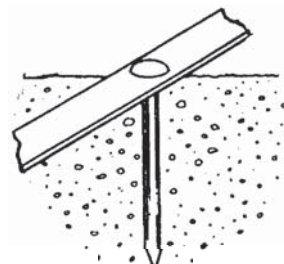

● **J-Hook Shaped Stake style**

This style is used when holes are not pre-drilled into the ground shoes (bars) or rear ground shoe (bar) of the goal. Similar to the peg or stake style, this anchor is hammered, at an angle if possible, directly into the earth. The curved (top) position of this anchor fits over the goal member to secure it to the ground (Figure 3.4). Typically, two to four stakes of this type are recommended (per goal), depending on stake structure, manufacturers specifications, weight of goal, and soil conditions. Stakes with larger diameters or textured surfaces have greater holding capacity.

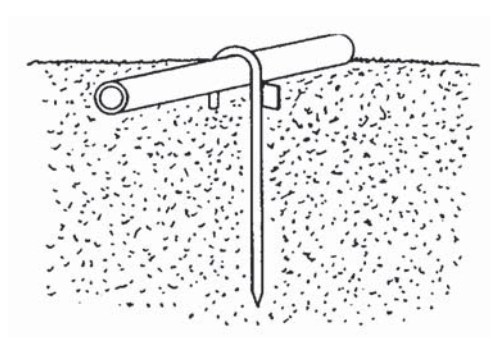

**Figure 3.4: J-Hook Anchor**

● **Sandbags/Counterweights**

Sandbags or other counterweights could be an effective alternative on hard surfaces, such as artificial turf, where the surface can not be penetrated by a conventional anchor (i. e., an indoor practice facility) (Figure 3.5). The number of bags or weights needed will vary and must be adequate for the size and total weight of the goal being supported.

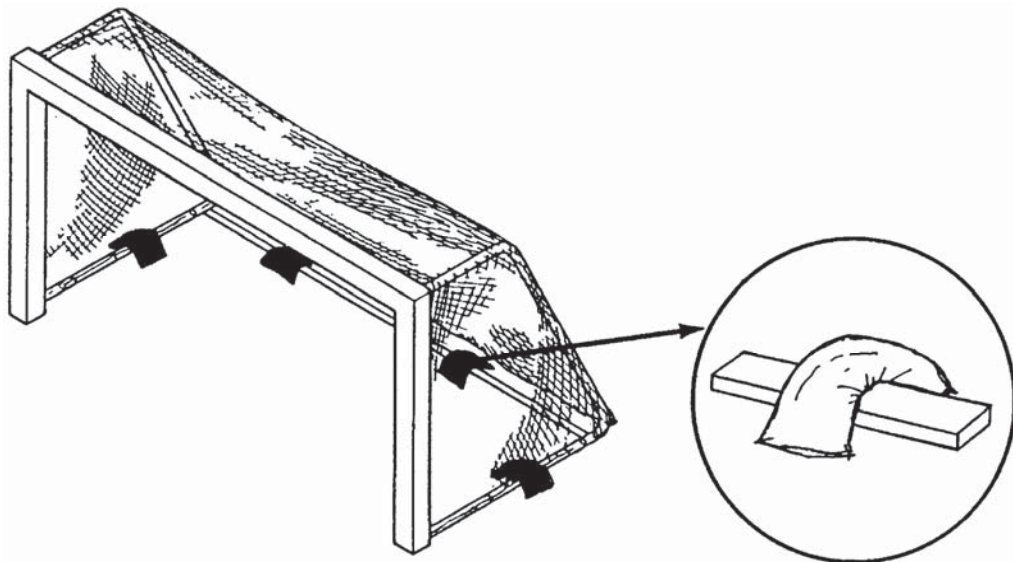

**Figure 3.5: Sandbag Method of Anchoring**

(Rear) Ground Bar/Shoe



● **Net Pegs**

These tapered, metal stakes should be used to secure only the NET to the ground (Figure 3.6). Net pegs should NOT be used to anchor the movable soccer goal.

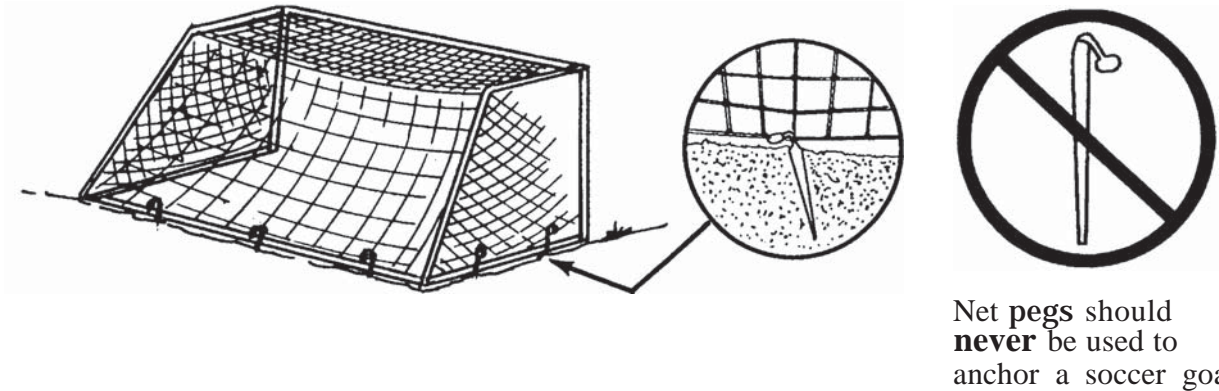
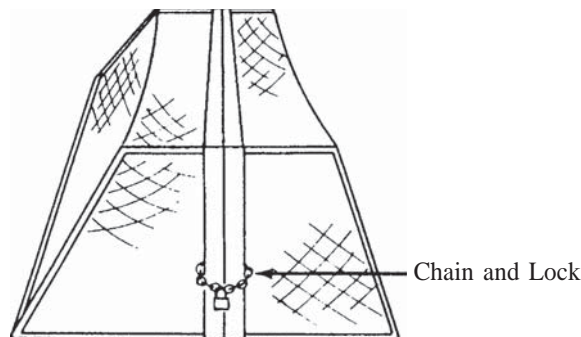

**Figure 3.6: Net Pegs**

**6. Guidelines for Goal Storage or Securing When Goal is Not in Use**

The majority of the incidents investigated by CPSC did not occur during a soccer match. Most of the incidents occurred when the goals were unattended. Therefore, it is imperative that all goals are stored properly when not being used. When goals are not being used always:

- a) Remove the net,
- b) Take appropriate steps to secure goals such as:
  - 1) Place the goal frames face to face and secure them at each goalpost with a lock and chain (see Figure 4.1 ),



**Figure 4.1: Join Goal Faces and Lock Together Using Chain and Lock**

- 2) Lock and chain to a suitable fixed structure such as a permanent fence (see Figure 4.2),
- 3) Lock unused goals in a secure storage room after each use,
- 4) If applicable, fully disassemble the goals for seasonal storage, or
- 5) If applicable, fold the face of the goal down and lock it to its base.

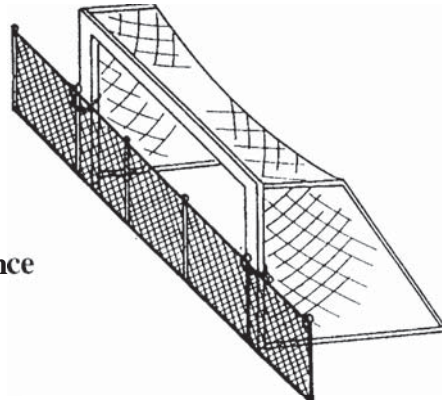

**Figure 4.2: Attach Goal Face to Permanent Fence with a Chain Lock**

## 7. Conclusions/Safety Tips

- Securely anchor or counterweight movable soccer goals at ALL times (see prior illustration).
- Anchor or chain one goal to another, to itself in a folded down position, or to nearby fence posts, dugouts, or any other similar sturdy fixture when not in use. If this is not practical, store movable soccer goals in a place where children cannot have access to them.
- Remove nets when goals are not in use.
- Check for structural integrity and proper connecting hardware before every use. Replace damaged or missing parts or fasteners immediately.
- NEVER allow anyone to climb on the net or goal framework.
- Ensure safety/warning labels (see Appendix C) are clearly visible (placed under the crossbar and on the sides of the down-posts at eye level).
- Fully disassemble goals for seasonal storage.
- Always exercise extreme caution when moving goals and allow adequate manpower to move goals of varied sizes and weights. Movable soccer goals should only be moved by authorized and trained personnel.
- Always instruct players on the safe handling of and potential dangers associated with movable soccer goals.
- Movable soccer goals should only be used on LEVEL (flat) fields.



## **Appendix A. List of Soccer Organizations**

### **Federation of International De Football Association**

Hitzigweg 11,8030  
Zurich, Switzerland  
Telephone 41-1-384-9595

### **National Federation of State High School Associations**

11724 NW Plaza Circle  
Box 20626  
Kansas City, Missouri 64195-0626  
Telephone (816) 464-5400

### **National Collegiate Athletic Association**

6201 College Blvd  
Overland Park, Kansas 66211-2422  
Telephone (91 3) 339-1906

## **APPENDIX B. For Further Information**

For further information on soccer goal anchors and/or to obtain **FREE** soccer goal warning labels (see Appendix C), safety alerts/bulletins and additional copies of this document, please contact:

### **The Coalition to Promote Soccer Goal Safety**

c/o Soccer Industry Council of America  
200 Castlewood Dr.  
North Plain Beach, FL 33408

or call any of these Coalition members:

800-527-7510  
800-334-4625  
800-243-0533  
800-531-4252

or write: U.S. Consumer Product Safety Commission  
Washington, D.C. 20207

To report a dangerous product or a product-related injury, call CPSC'S toll-free hotline at (800) 638-2772 or CPSC'S teletypewriter at (301) 595-7054. Consumers can get recall information via Internet gopher services at [cpsc.gov](http://cpsc.gov) or report product hazards to [info@cpsc.gov](mailto:info@cpsc.gov).

This document is in the public domain. It may be reproduced in part or in whole by an individual or organization without permission. If it is reproduced, however, the Commission would appreciate knowing how it is used. Write the U.S. Consumer Product Safety Commission, Office of Information and Public Affairs, Washington, D.C. 20207."

The U.S. Consumer Product Safety Commission (CPSC) is an independent regulatory agency charged with reducing unreasonable risks of injury associated with consumer products.

Appendix C. Warning Labels

**⚠ WARNING**

**ALWAYS ANCHOR GOAL**

Unsecured Goal Can Fall Over  
Causing Serious Injury or Death

**⚠ WARNING**



Never climb or hang on goal.  
Goal can fall over causing  
serious injury or death.

**⚠ WARNING**



**NEVER CLIMB OR HANG ON GOAL**

Goal Can Fall Over Causing  
Serious Injury or Death

**⚠ WARNING**

**Always anchor goal.**

Unsecured goal can fall over  
causing serious injury or death.

## **APPENDIX H – SCHOOL NETWORK INFRASTRUCTURE REQUIREMENTS**

# **SCHOOL NETWORK INFRASTRUCTURE REQUIREMENTS 2023**

**As technology device models change frequently, design consultants should confirm with the Department of Transportation and Infrastructure (DTI) with regard to current and/or upgraded requirements at time of design.**

Hardware referenced in this document represents the 2023 standards for schools in Newfoundland and Labrador. As new hardware models are released by the vendors, these specific models may be replaced and new standards established.

Consultants should submit the design drawings with exclusively Information Technology (IT) components (network jacks, WAPs, switches, etc.) shown.

# **SCHOOL NETWORK INFRASTRUCTURE REQUIREMENTS 2023**

## **WIRELESS TECHNOLOGY**

The Aruba 505 Series Access Point (AP) is the current standard for implementation of wireless networks in schools throughout Newfoundland and Labrador. Consultants should confirm specific device model availability immediately in advance of tender. Should this model be unavailable/replaced by vendor, submit alternative to DTI for approval.

Each Aruba wireless access point must also include the Airwave management license in the purchase.

Wireless implementation must deliver the following deployment standards:

1. All instructional/administrative areas (classrooms, learning resource centers, general office, Instructor's lounge, etc.) must have a minimum of a single wireless access point (two Ethernet jacks, mounted centrally in the room visible on the ceiling. These two Ethernet jacks will support future wireless expansion and high density wireless access points.)
2. Hallways must have wireless access points deployed to provide for reliable wireless capacity the full length of the hallway.
3. For areas where large numbers of students (devices) may congregate (e.g. cafeteria/multipurpose room, gymnasium, etc.), necessary wireless access points must be deployed based on the occupancy limits for these rooms to achieve reliable, stable wireless signal. Each space having at least one unit and one additional unit per 150 occupants; devices should be spread out in the rooms to achieve optimal functionality.
4. Access points that are mounted on walls in areas such as gymnasiums where the wireless access point could be exposed to blunt force from objects such as basketballs etc. must be adequately covered to protect the access point from damage, while minimizing impact on the signal transmission.
5. Mounting height of any access point should not exceed 10 feet.
6. All wall mounted wireless access points shall be Aruba 504 with external antennas and adequate mounting hardware and Airwave license.
7. Where the mounting hardware that is provided with the wireless access point isn't sufficient, additional mounting hardware brackets must be provided as per the manufacturer's specifications.
8. Contractors are required to install the Aruba wireless access points with mounting brackets and connect the adequate data patch cable.

## **SCHOOL NETWORK INFRASTRUCTURE REQUIREMENTS 2023**

9. Contractors must provide documentation of room numbers and the corresponding MAC address of the wireless access point to DTI. Wireless configuration will be completed by DTI.

### **SWITCHING TECHNOLOGY**

The Aruba CX 6100 series switch is the current standard for LAN network access switches in new school construction in Newfoundland and Labrador. Consultants should confirm specific device model availability immediately in advance of tender. Should this model be unavailable/replaced by vendor, submit alternative to DTI for approval.

Schools designed for in excess of 300 students shall also have an Aruba CX 6300M aggregation switch for its network core.

Each Aruba network switch must also include the Airwave management license in the purchase.

Provisioning of network switches must include a 10% overage of free PoE ports, 20% of PoE wattage available and 10% overage of free non-PoE ports in each data closet/rack.

### **ARUBA NETWORK SWITCH MODELS**

Aruba CX 6100 48G 4SFP+	#JL676A
Aruba CX 6100 48G PoE+ 4SFP+	#JL675A
Aruba CX 6100 24G 4SFP+	#JL678A
Aruba CX 6100 24G PoE+ 4SFP+	#JL677A
Aruba CX 6300M 10GB 24SFP+	#JL658A

### **PRIMARY DATA ROOM (including SERVER)**

The Primary Data Room would connect to all other data closets via a star topology with fiber connectivity to each.

Multi-Mode fiber OM3/OM4 50 micron, with 12 strands, will be used to connect all data closets to the primary data room.

Contractor provided full size, floor mounted, two post data rack.

Room shall not be designed for any other school functions or purposes.

Demarcation of fiber connection from service provider must terminate in Primary Data Room.

The room should have the following specifications:

- 8ft x 8ft room.
- Air conditioning.
- Phone service.

## **SCHOOL NETWORK INFRASTRUCTURE REQUIREMENTS 2023**

- Walls, ceiling, and doors sound-isolated from other occupied areas.
- No windows because of security and sound.
- 1 installed wireless access point
- Adequate electrical outlets and 4 data drops on wall next to server.

### **SECONDARY DATA CLOSETS**

- Wireless access point within 30 feet
- Floor or wall mounted data rack
- Adequate electrical power to service network equipment

### **FIBER TRANSCEIVERS - SCHOOLS LESS THAN 300 STUDENTS**

From each Secondary Data Closet to the Primary Data Room a fiber pair for the PoE stack of switches and a fiber pair for the Non-PoE stack of switches will be utilized, see Figure 1.

All fiber connections must use and include adequate fiber transceivers for 10GbE connectivity between data closets.

All fiber connections must use and include adequate fiber transceivers for 10GbE connectivity between network switches within each data closet.

Aruba 10G SFP+ LC SR MMF #J9150D (Transceiver)

# SCHOOL NETWORK INFRASTRUCTURE REQUIREMENTS 2023

**Figure 1: School – Enrollment Less than 300 student**

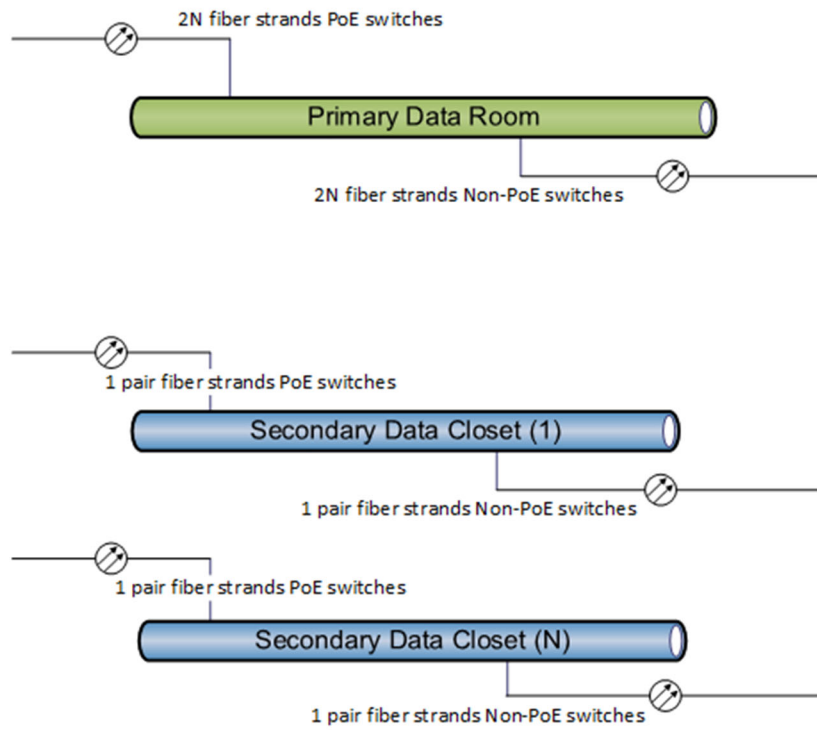



# SCHOOL NETWORK INFRASTRUCTURE REQUIREMENTS 2023

## FIBER TRANSCEIVERS - SCHOOLS MORE THAN 300 STUDENTS

From each Secondary Data Closet to the Primary Data Room all fiber pairs will be used to connect as many switches from the Secondary Data Closets to Aruba CX 6300M and other adequate CX 6100 switches in the Primary Data Room directly, see Figure 2.

All fiber connections must use and include adequate fiber transceivers for 10GbE connectivity between data closets.

All fiber connections must use and include adequate fiber transceivers for 10GbE connectivity between network switches within each data closet where fiber to the Primary Data Closet is consumed.

Aruba 10G SFP+ LC SR MMF #J9150D (Transceiver)

**Figure 2: School – Enrollment More Than 300 Students**

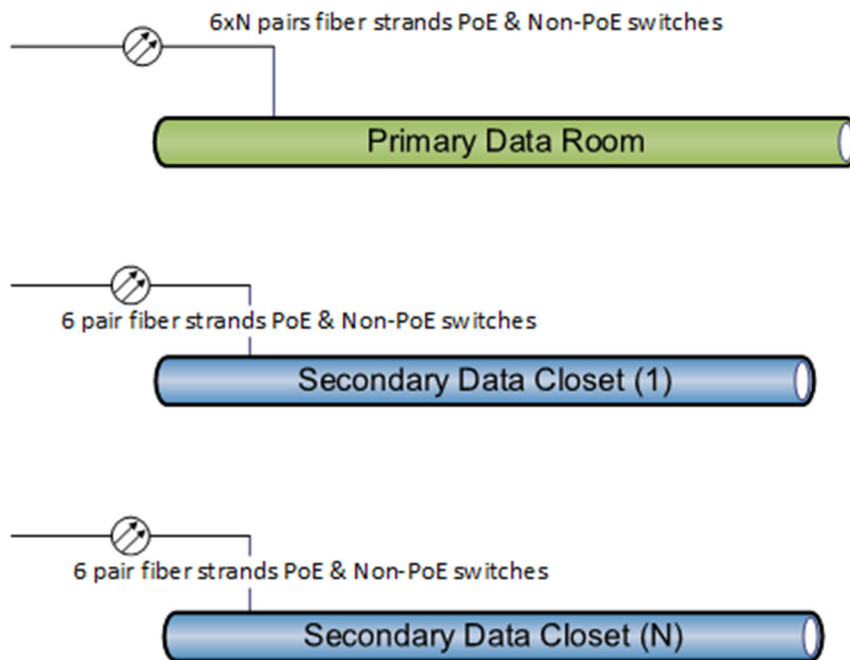

# SCHOOL NETWORK INFRASTRUCTURE REQUIREMENTS 2023

## **Fiber Patch Cables**

Must include the adequate fiber patch cables to connect to all ports in all switches.

HPE 0.5 m Multimode OM3 LC/LC Optical Cable (AJ833A)

HPE 1 m Multimode OM3 LC/LC Optical Cable (AJ834A)

HPE 2 m Multimode OM3 LC/LC Optical Cable (AJ835A)

HPE 5 m Multimode OM3 LC/LC Optical Cable (AJ836A)

HPE 15 m Multimode OM3 LC/LC Optical Cable (AJ837A)

HPE 30 m Multimode OM3 LC/LC Optical Cable (AJ838A)

HPE 50 m Multimode OM3 LC/LC Optical Cable (AJ839A)

HPE Premier Flex LC/LC Multi-mode OM4 2 fiber 1m Cable (QK732A)

HPE Premier Flex LC/LC Multi-mode OM4 2 fiber 2m Cable (QK733A)

HPE Premier Flex LC/LC Multi-mode OM4 2 fiber 5m Cable (QK734A)

HPE Premier Flex LC/LC Multi-mode OM4 2 fiber 15m Cable (QK735A)

HPE Premier Flex LC/LC Multi-mode OM4 2 fiber 30m Cable (QK736A)

# SCHOOL NETWORK INFRASTRUCTURE REQUIREMENTS 2023

## DATA RACK ORGANIZATION

- Contractor shall supply, install and rack the network switches and patch panels to be adjacent to each other.
- PoE arranged in the middle to lower section of the rack.
- Non-PoE arrange in the upper area of the rack
- For schools with more than 300 students, in the Primary Data Room, the Aruba CX 6300M aggregation switch is installed in the top area of the rack.
- Contractor supplied copper data patch cables for the data rack shall be 30cm or 60 cm patch cords to tie in patch cables to the adjacent network switch along with adequate overage of cables.
- Copper clad cables are not permitted.

**Data Rack Illustration**

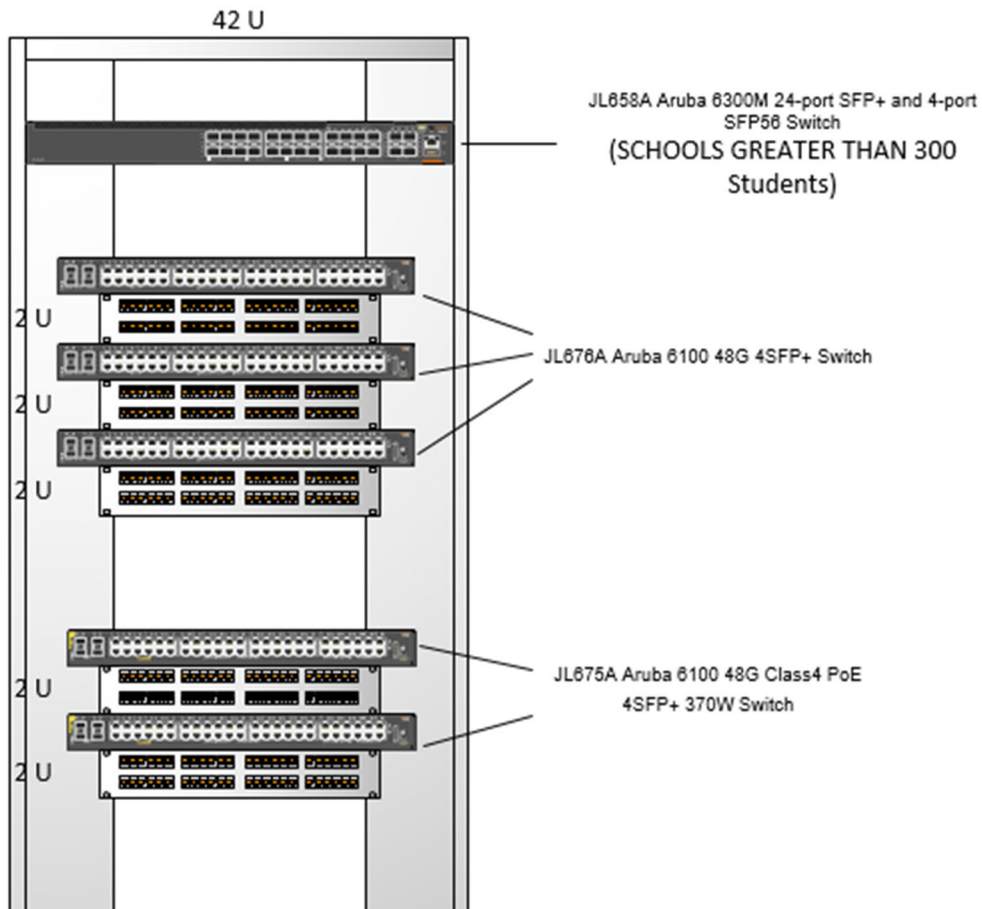

## **SCHOOL NETWORK INFRASTRUCTURE REQUIREMENTS 2023**

### **DATA JACK /CABLE TESTING**

Contractor shall provide to the owner an electronic copy of a detailed reference report that includes the mapping of room number / data jack numbers to the corresponding data rack/closet - patch panel and port number.

Contractor shall provide to the owner an electronic copy of the data jack certification report that includes the mapping of room number / data jack numbers to the corresponding data rack/closet - patch panel and port number.

In order for a data cable to pass, the cable being tested must consistently pass testing at least 95% of the time in repeated cable certification tests.

### **DATA CABLING / TERMINATIONS / ACCEPTABLE BRANDS**

Terminations shall be either Belden or Panduit with no substitutes accepted. Data cabling shall be Belden CAT6+ Enhanced, 23 AWG solid copper conductors, Plenum-CMP, Flamarrest PVC-LS Jacket or equivalent Panduit.

# SCHOOL NETWORK INFRASTRUCTURE REQUIREMENTS 2023

## DATA JACK REQUIREMENTS

### ADMINISTRATION AREAS

#### Administration Office

- 1 data jack per staff person plus 2 data jacks for the printers.

#### Administrator/Principal

- 2 data jacks per office.

#### Assistant Administrator/Vice Principal Offices

- 2 data jacks per office.

#### Digital Records / Copier Room

- 4 data jacks.

#### Staff/Instructor's Preparation Room

- 1 per every 6 instructors, plus 2 for the printer.

## INSTRUCTIONAL SPACES

### Kindergarten

- 12 data jacks:
  - 4 at Instructor's Desk including adequate pass-through grommets for HDMI/USB cables to Instructor's Computer.
  - 4 at back wall.
  - 2 at center of ceiling.
  - 2 behind ITV at front of classroom including adequate pass-through grommets for HDMI/USB cables to ITV.

### Primary (Grades 1-3)

- 12 data jacks:
  - 4 at Instructor's Desk including adequate pass-through grommets for HDMI/USB cables to Instructor's Computer.
  - 4 at back wall.
  - 2 at center of ceiling.
  - 2 behind ITV at front of classroom including adequate pass-through grommets for HDMI/USB cables to ITV.

### Elementary (Grades 4-6)

- 12 data jacks:
  - 4 at Instructor's Desk including adequate pass-through grommets for HDMI/USB cables to Instructor's Computer
  - 4 at back wall.
  - 2 at center of ceiling.
  - 2 behind ITV at front of classroom including adequate pass-through grommets for HDMI/USB cables to ITV.

# **SCHOOL NETWORK INFRASTRUCTURE REQUIREMENTS 2023**

## **Intermediate (Grades 7-9)**

- 12 data jacks:
  - 4 at Instructor's Desk including adequate pass-through grommets for HDMI/USB cables to Instructor's Computer.
  - 4 at back wall.
  - 2 at center of ceiling.
  - 2 behind ITV at front of classroom including adequate pass-through grommets for HDMI/USB cables to ITV.

## **High School (Grades 10-12 / Levels I-III)**

- 12 data jacks:
  - 4 at Instructor's Desk including adequate pass-through grommets for HDMI/USB cables to Instructor's Computer.
  - 4 at back wall.
  - 2 at center of ceiling.
  - 2 behind ITV at front of classroom including adequate pass-through grommets for HDMI/USB cables to ITV.

## **Art Room (Dry Media Zone)**

- 12 data jacks:
  - 4 at Instructor's Desk including adequate pass-through grommets for HDMI/USB cables to Instructor's Computer.
  - 4 at back wall.
  - 2 at center of ceiling.
  - 2 behind ITV at front of classroom including adequate pass-through grommets for HDMI/USB cables to ITV.

## **Computer Lab (CDLI)**

- 6 data jacks:
  - 4 at Instructor's Desk including adequate pass-through grommets for HDMI/USB cables to Instructor's Computer.
  - 2 per every 6 students data jacks (min. 6).
- 1 telephone line.

## **Computer Lab (ICLT)**

- 32 data jacks:
  - 30 (15 dual data jacks).
  - 2 data jacks at the instructor's desk.
- 1 telephone line.
- pre-wired speaker system with flush-mounted wall jacks.

## **Home Economics**

- 10 data jacks:
  - 6 data jacks (in textile instruction area).
  - 4 at Instructor's Desk including adequate pass-through grommets for HDMI/USB cables to Instructor's Computer.

# **SCHOOL NETWORK INFRASTRUCTURE REQUIREMENTS 2023**

## **Instructional Resource Room (IRR)**

- 10 data jacks:
  - 4 at Instructor's Desk including adequate pass-through grommets for HDMI/USB cables to Instructor's Computer.
  - 2 at back wall.
  - 2 at center of ceiling.
  - 2 behind ITV at front of classroom including adequate pass-through grommets for HDMI/USB cables to ITV.
- 1 telephone line.

## **Music Room**

- 22 data jacks:
  - 2 per every 6 students (max. 10).
  - 4 at Instructor's Desk including adequate pass-through grommets for HDMI/USB cables to Instructor's Computer.
  - 4 at front of room in Clock/Intercom panel/chase.
  - 2 at back wall.
  - 2 at center of ceiling.
  - 2 behind ITV at front of classroom including adequate pass-through grommets for HDMI/USB cables to ITV.

## **Science Laboratories/Multi-Purpose**

- 1 per every 6 students.
- 4 at Instructor's Desk including adequate pass-through grommets for HDMI/USB cables to Instructor's Computer.

## **Chemistry/Multi-Purpose**

- 1 per every 6 students.
- 4 at Instructor's Desk including adequate pass-through grommets for HDMI/USB cables to Instructor's Computer.

## **Physics/Multi-Purpose**

- 1 per every 6 students.
- 4 at Instructor's Desk including adequate pass-through grommets for HDMI/USB cables to Instructor's Computer.

## **Theatre/Drama**

- adequate data jacks for equipment as required (computers, overhead projectors, sound equipment and speakers etc.).
- adequate electrical outlets (tamper-proof duplex electrical receptacles); provide pre-wiring for the installation of audiovisual and computer equipment.

## **Applied Technology Laboratory (Intermediate Grades 7-9): Fabrication Room**

- 4 data jacks.

## **Planning/Design Room**

- 20 data jacks:
  - 1 per every 2 students (max. 12).

## **SCHOOL NETWORK INFRASTRUCTURE REQUIREMENTS 2023**

- 4 at Instructor's Desk including adequate pass-through grommets for HDMI/USB cables to Instructor's Computer.
- 2 at center of ceiling (for wireless access point).
- 1 behind ITV at front of classroom including adequate pass-through grommets for HDMI/USB cables to ITV.

### **Skilled Trades Laboratory (High School - Levels I- III):**

#### **Fabrication Room**

- 4 data jacks.

#### **Planning/Design Room**

- 20 data jacks:
  - 1 per every 2 students (max. 12).
  - 4 at Instructor's Desk including adequate pass-through grommets for HDMI/USB cables to Instructor's Computer.
  - 2 at center of ceiling (for wireless access point).
  - 1 behind ITV at front of classroom including adequate pass-through grommets for HDMI/USB cables to ITV.

## **SPECIALIZED SPACES**

### **Fitness Centre**

- adequate data jacks for all fitness machines.
- adequate electrical outlets (tamper-proof duplex electrical receptacles); provide not less than one electrical power circuit for every 3 pieces of electrically powered equipment.

### **Guidance/Itinerant Instructor's Suite**

- 6 data jacks:
  - 4 (2 in large office; 1 in each small office).
  - 2 in the waiting area.

### **Gymnasium**

- 1 per 100m<sup>2</sup>.

### **Gym Instructor's Office**

- 2 data jacks.

### **Gym Platform**

- 6 data jacks (2 at each wall).

## **GENERAL SPACES:**

### **Kitchen**

- 1 data jack at pay station in server.
- 1 telephone line.



# SCHOOL NETWORK INFRASTRUCTURE REQUIREMENTS 2023

## Library / Learning Resource Center

- 12 data jacks:
  - 4 at Circulation Desk.
  - 2 per every 6 students (min. 6).
  - 2 behind ITV at front of classroom including adequate pass-through grommets for HDMI/USB cables to ITV.
- 1 telephone line.

## Lunch / Multipurpose Room

- 8 data jacks:
  - 4 dual data jacks equally distributed around Lunch Room (min. one per 25m<sup>2</sup>).

## UTILITY AREAS

Structured network cabling solution must provide sufficient jacks for all building systems e.g. Energy management and monitoring systems, card access system, CCTV, public address system, etc. Electrical consultant to engage with all disciplines to ensure needs and locations are identified.

All utility and service equipment being connected to the network must have MAC addresses submitted to DTI **in advance** such that IPs can be assigned. The contractor must supply information as per below example:

### Example

Device	MAC	Location
Card Access	00:11:22:33:44:55	Main data room 112
DDC Main Board	11:22:33:44:55:66	Main mechanical room 223
DDC secondary board	22:33:44:55:66:77	Main mechanical room 223
PA system	33:44:55:66:77:88	Equipment room by office 111

**The list must be comprehensive for all devices.**

## **SCHOOL NETWORK INFRASTRUCTURE REQUIREMENTS 2023**

### **INTERACTIVE TELEVISIONS (ITV):**

Provide rough-ins for tamper-proof duplex electrical power receptacles and data ports/drops in the wall behind ITV and at a location at the center of and directly above the ITV. Ensure that all tamper-proof duplex electrical power receptacle boxes that are exposed and above the board are located two feet from the center of the board and 10" above the wall-mounting bracket.

Ensure that all Interactive Televisions (ITV) have a USB port for connection by USB cable to a computer. Ensure that all Interactive Televisions (ITV) use a cable only system. Use a USB Extender over Cat5e or Cat6 Connection.

Locate the ITV in the center of the front wall of instructional spaces between the Clock/Intercom panel-chase near the main entrance and the Data Communications panel-case near the instructor's desk opposite. Locate all data jacks, duplex electrical outlets, and pass-through grommets for HDMI/USB cables to ITV in the Data/Communications panel/chase adjacent to the instructor's desk.

Ensure that all connections to the ITV from the panel-chase are made through the above-ceiling space using surface-mounted conduit (and/or tech or plenum-rated cable) – do not use conduit concealed in the wall for these connections. Do not use surface-mounted wire-mold below the ceiling except in limited use directly behind and above the ITV for connection to the above-ceiling space

Provide adequate cables for each ITV:

USB CABLE: 1 x Tripplite USB 2.0 TYPE A to B Active Repeater Cable M/M 50ft, #U042-050 or equivalent (as confirmed by DTI).

FIBER OPTIC HDMI CABLE: 1 x Tripplite #P568F-15M-8K6 or Infinite Cables #HDMI-250-50PL or equivalent (as confirmed by DTI).

# SCHOOL NETWORK INFRASTRUCTURE REQUIREMENTS 2023

## *Illustration 1: ITV Height*

### **Fixed Wall Mount**

\*Recommended Height of ITV s from floor to bottom edge of TV

Kindergarten	610mm
Primary	660mm
Elementary	711mm
Intermediate/High School	813mm

### **Manual Height Adjustable Mount**

When using Floor Supported-Wall Attached-Manual Height adjustable system for ITV 's: Viewsonic Balancebox 400 part#VB-BLF-002, this provides for a 15.75" / 400mm user height adjustable solution.

<https://www.viewsonic.com/us/vb-blf-002.html>

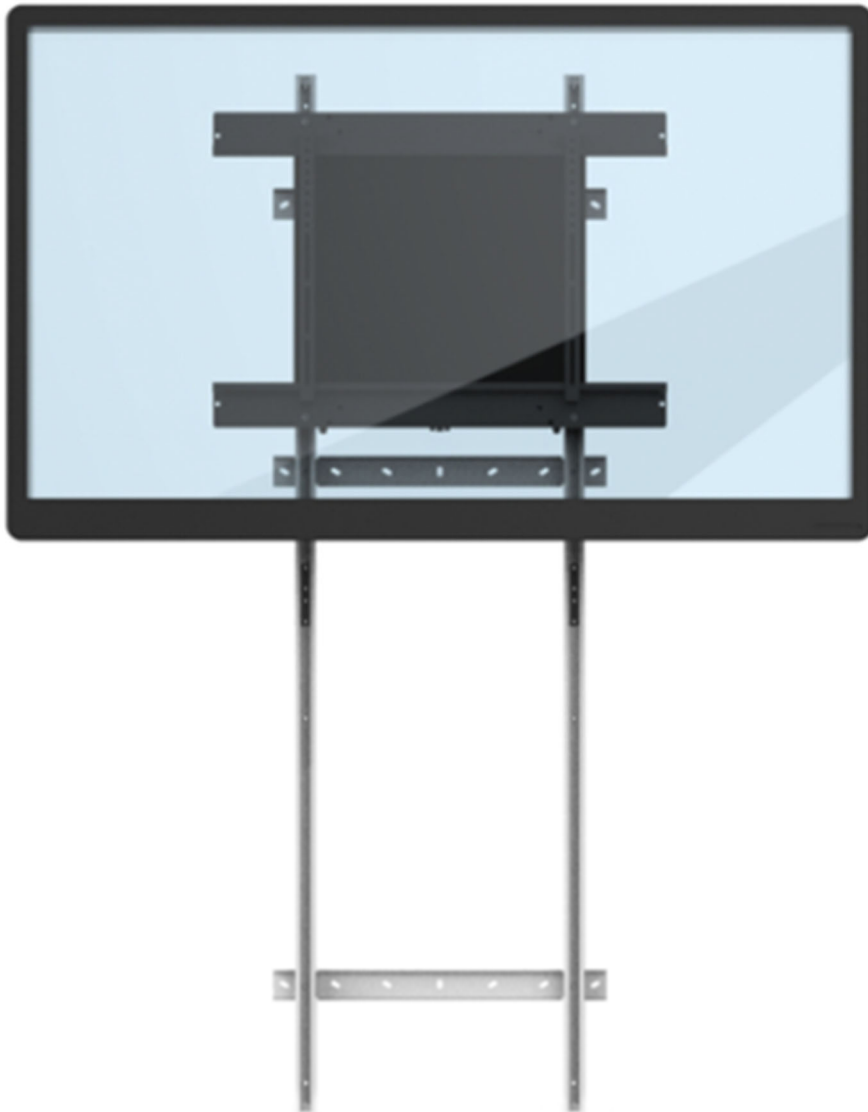

# SCHOOL NETWORK INFRASTRUCTURE REQUIREMENTS 2023

Illustration 2: ITV Mock Up

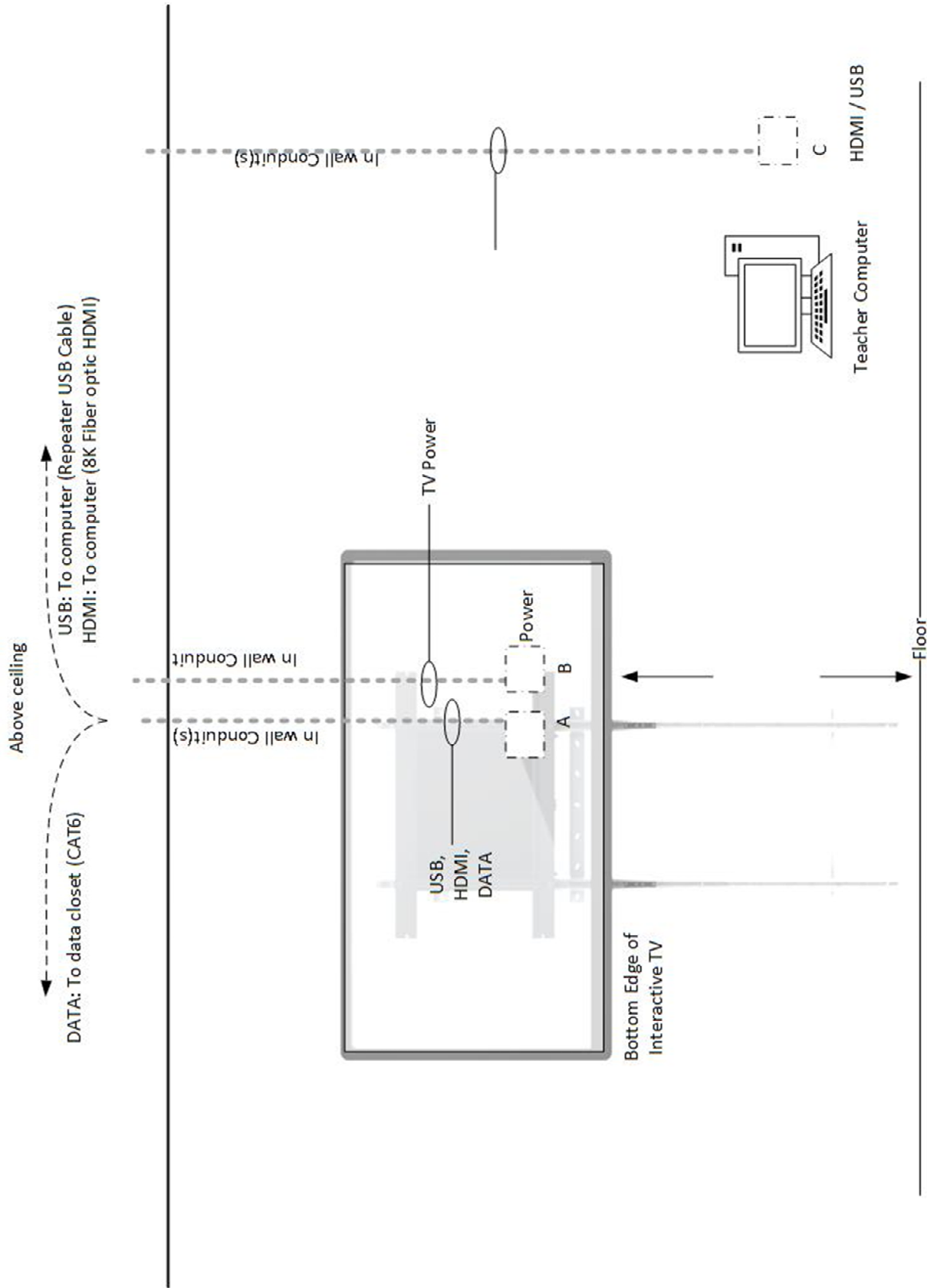

**SCHOOL NETWORK INFRASTRUCTURE REQUIREMENTS  
2023**

*Illustration 3: Materials for ITV*

<p>TrippLite USB 2.0 TYPE A to B Active Repeater Cable M/M 50ft, #U042-050</p>	
<p>C2G 1.5" Grommets Cable Pass-through Double Gang, #40546</p>	
<p>C2G 1" Grommets Cable Pass-through Single Gang, #40488</p>	

# SCHOOL NETWORK INFRASTRUCTURE REQUIREMENTS 2023

**HDMI Active Fiber  
Optic 8K@60Hz,  
48Gbps Plenum Rated;**

Infinite Cables #HDMI-  
250-50PL

Or

Tripplite #P568F-15M-  
8K6



# SCHOOL NETWORK INFRASTRUCTURE REQUIREMENTS 2023

## SUMMARY TABLE

Room	Data Jacks	Interactive Televisions	Phone Line
<b>Administration Spaces:</b>			
Administration Office	1/p + 2		
School Population < 300p			1
School Population > 300p			2 + 1 fax
Principal	2		1
Vice Principal	2		1
Digital Records Room	4		0
Staff/Teacher Prep Room	1/6p + 2		1
<b>Instructional Spaces:</b>			
Kindergarten	12	1+HDMI/USB	
Primary (Grades 1-3)	12	1+HDMI/USB	
Elementary (Grades 4-6)	12	1+HDMI/USB	
Intermediate (Grades 7-9)	12	1+HDMI/USB	
High School (Grades 10-12/LI-III)	12	1+HDMI/USB	
Art Room	12	1+HDMI/USB	1
Computer Lab: CDLI	6	1+HDMI/USB	
Computer Lab: ICLT	32	1+HDMI/USB	1
Home Economics	10	1+HDMI/USB	
Instructional Resource Room (IRR)	10	1+HDMI/USB	1
Music Room	22	1+HDMI/USB	
Science/Chem/Bio/Phys Labs	1/6p + 4	1+HDMI/USB	
Theatre/Drama	as Req.	1+HDMI/USB	
<b>Applied Tech Lab (Grades 7-9):</b>			
Fabrication Room	4		
Planning/Design Room	20	1+HDMI/USB	
Skilled Trades Lab (Grades 10-12)			
Fabrication Room	4		
Planning/Design Room	20	1+HDMI/USB	
<b>Specialized Spaces:</b>			
Fitness Centre	as Req.		
Guidance Suite	6		
Gymnasium	1/100m <sup>2</sup>		
Gymnasium Instructor's Office	2		
Gym Platform	6		
<b>General Spaces:</b>			
Corridors	2/10m		
Kitchen	1		1
Library/Learning Resource Center	12 (2/6p)	1+HDMI/USB	1
Lunch/Multipurpose Room	8		

## **APPENDIX I – CARD ACCESS SYSTEM (KANTECH)**



## KANTECH INSTALLATION

1. Only use KT-400 systems (this model has integrated network and is required for multi-swipe functionality). Only one controller is network connected, and where they are required, other controllers are slaved off that main.
2. Kantech system will be integrated with School Kantech server:
  - a. No control software to be installed at school sites;
  - b. No “test configurations” to be done on controllers – coordinate with DTI for installation and verification;
  - c. DTI will add site and connection on server, and make someone available remotely in coordination with vendor onsite for performance verification.
3. Technician installing panel to be an official Kantech trained integrator.
4. KT-400 panels to be installed in an accessible location (eye-height) in the electrical/communications room.
5. Grounding via 18ga wire to be installed by contractor from Kantech system e.g. to the existing telecommunications ground in the same room.
6. EOL resistors to be installed on input devices.
7. Doors to be controlled:
  - a. Exterior and interior doors on the main and bus entrances (4 doors in total);
  - b. Exterior door closest to the dumpster (if not already included in “a”);
  - c. Exterior door closest to the playground/sports field (if not already included in “a”);
  - d. Fitness room (where present).
  - e. Family Resource Centre (where not using main entrance).
  - f. Card readers to be installed on exterior of building for exterior doors, as well as inside for interior doors.
8. Rex and door contacts to be supplied and installed on all exterior Kantech controlled doors, as well as door contacts integrated with Kantech system for all exterior gymnasium doors (which may not have card readers/electric strikes, unless they do per #7).
9. Main door intercom/release system (e.g. Aiphone) to be integrated as secondary rex with KT-400.
10. Automatic door openers to be integrated with KT-400 via integration module and configured on Kantech Server CE.
11. Lockdown button in the main office to be integrated directly into the KT-400 as an input. Task builder on the server used to create a smart link operation to lock & disable all card access doors at site.

## **APPENDIX J – CLOSED CIRCUIT TELEVISION SYSTEM**

## **CLOSED CIRCUIT TELEVISION SYSTEM**

The closed circuit television (CCTV) system vendor must supply and install all system equipment and components to deliver a fully functioning CCTV system using only qualified personnel for cable terminations.

CCTV system generally includes but is not limited to:

- 32 channel Network Video Recorder (NVR).
- Cameras with motorized varifocal lens and autofocus.
- POE switches (unless integrated with NVR).
- Configuration of up to two (2) owner-supplied PCs with manufacturer software for remote viewing and/or configuration.
- Cat 5e/6 Ethernet data cable.
- 1500 VA UPS for network video recorder and switch.
- All miscellaneous wiring, connectors, clamps, brackets, and cables etc. for the complete installation.

The system vendor shall have a minimum of five years experience in the CCTV industry and supply all necessary equipment, material, and labour to furnish, install, and verify correct operation of the system. Installation by the vendor shall include all required wiring to contract-provided cameras.

The vendor must coordinate with the owner to determine the arrangement and location of all security equipment installed and provide the services of a qualified technician to train operating and maintenance personnel.

Following installation, the vendor must conduct testing of the system to ensure satisfactory performance and submit a written report detailing tests performed and results. The vendor shall be responsible for the provision of all equipment, materials and labour required for system tests. Testing will verify that all cameras can be simultaneously viewed and that the integrated system works to the meet the Owner's requirements.

The vendor shall supply a CCTV system including, but not limited to, the following equipment with the associated specifications:

### **Network Video Recorder (NVR)**

Vendor must provide an intelligent digital video recording, retrieval and management/scheduling system with the following features:

- Minimum 4TB HDD (expandable to 36TB)
- Capacity for 32 channels
- Software to display all 32 channels at remote PC.
- Video search retrieval
- Motion detection recording
- 2-16X zoom.
- Network boards
- Third party camera support
- Motion Detector Board
- HDMI and VGA Outputs.
- Min 2 USB 2.0 ports
- C/w keyboard, mouse, and monitor.

### **Cameras**

The vendor must provide cameras that meet the following criteria:

- 4 MP resolution.
- HD1080P Video.
- Vandal Resistant (withstands 20 joules of impact energy).
- IR Range 30 meters.
- IP66 weather rating (-30 - 60C)
- Humidity 95% or less (non-condensing)
- 2.8 mm to 12mm motorized lens.
- Auto focus.
- Wide Dynamic Range (WDR).
- POE (802.3af)
- Digital noise reduction.
- Video Compression: H.264+,H.264,MJPEG
- Alarm Triggers:
  - Motion
  - Intrusion detection
- Security:
  - User Authentication
  - Watermark

### **POE Switch (\*if note integrated with NVR)**

The vendor must provide:

- 32 usable ports to correspond to NVR to allow for camera expansion.
- Camera power with 802.3af POE standard on all ports.

### **Cables**

The vendor must provide:

- Cables with Cat5E minimum standard (refer to camera layout).
- All required interconnection wiring.
- All required termination equipment.
- Connections from to all monitors to the main equipment using Ethernet cable in EMT conduit.

### **UPS (Uninterruptible Power Supply)**

The vendor must supply a 1500VA UPS that is connected to the POE Switch and NVR.

## **TRAINING AND OPERATION & MAINTENANCE MANUALS**

Training and the provision operation and maintenance manuals shall be required of the vendor.

O&M Manuals shall be submitted to the Owner's Representative for review and approval. O&M manuals must provide manufacturer details on each item of equipment in the system including the following:

- Video cameras.
- Auto-iris motorized varifocal lens.
- Network video recorder

Training of School and DTI staff in system operation must include a minimum of two sessions of two hours each for instruction and orientation (one training session after commissioning and another approximately one a month later) and shall include:

- Searching for video on specific date and time.
- Exporting video to USB drive.

## **APPENDIX K – STANDARD SCHOOL SPATIAL PROGRAMS 2023**

Standard School Spatial Program Primary K-3 (2023 Class Caps)						
Theoretical one class per grade enrollment scenario:						
Room	Program					
	Enrollment	Class Caps	# Classes	# Rooms	Area / p m <sup>2</sup>	Room Area m <sup>2</sup>
Room	Area	Formula				
K*	85.00	85sqm incl. washroom x k/20p/2				
1	67.50	pop/25p x 2.7sqm/p	1	1.00	2.70	85.00
2	67.50	pop/25p x 2.7sqm/p	1	1.00	2.70	67.50
3	67.50	pop/25p x 2.7sqm/p	1	1.00	2.70	67.50
1-3	75					
<b>SubTotal</b>	<b>287.50</b>		<b>4</b>			
Contingency	67.50	total classrooms x .10	1		2.70	67.50
<b>Classroom SubTotal</b>	<b>355.00</b>					
Instructional Resource Room	20.00	1/200p, 20sqm; min. 1, max 3	1			20.00
Instructional Resource Suite	65.00	55sqm - 65sqm	1			65.00
IRS Washroom	9.18	1x9.18sqm	1			9.18
Science Preparation	20.00	1 x 20sqm	1			20.00
Library/Resource	65.00	.4sqm /p 1-6 pop; max 200sqm + 35sqm media lab	1	0.40		65.00
Music	78.00	1 x 78sqm	1			78.00
Lunch/Multipurpose	47.25	90% pop/2 x 1.4sqm + recycling/vending area	1	1.40		47.25
Kitchen	62.00	Serving <200p,62sqm; <250p, 68sqm; <300p, 87; <400p,100sqm; <500p, 114sqm	1			62.00
Canteen	8.00	1 x 8sqm/400p	1			8.00
Gymnasium	389.00	<400p, 389sqm;<800p, 588sqm	1			389.00
Change/Instr/Storage	90.00	<400p, 90sqm; >400p, 135sqm	1			90.00
Stage	50.00	1 x 50sqm	1			50.00
Administration	20.00	<150p,20sqm; <250p,25sqm; <600p,65sqm; <700p,80sqm; >700p, 90sqm max	1			20.00
Staff / Preparation	46.50	18sqm + .3sqm/p >100p, max 175sqm	1	0.30		46.50
Staff Showers	7.00	2 x 3.5sqm	2			7.00
Sick/Washroom	15.00	1 x 15sqm	1			15.00
Unisex Washroom	5.00	1x5sqm	1			5.00
Guidance/Itinerent/Wait	8.00	3 x 8sqm	3			8.00
Family Resource Center	68.00	68sqm if included	0			68.00
Storage	10.00	1sqm/10p	1			10.00
Utility	15.00	1 x 15sqm	1			15.00
Lobby	40.00	.15sqm/p; min 40sqm, max 105sqm	1			40.00
<b>Core Spaces Subtotal</b>	<b>1095.53</b>					
<b>Total</b>	<b>1450.53</b>					
<b>Grossing Factor</b>	<b>1.50</b>					

**Notes:**  
Above spatial program analysis demonstrates a theoretical one class per grade enrollment scenario.  
Potential alternative grade configurations employ similar formula adjusted according to the combination of grades represented.  
Very small school enrollments employ a spatial allocation specific to the particular circumstances encountered.  
\*K Cap is raised to 28 where team teaching employed.

Standard School Spatial Program Elementary 4-6 (2023 Class Caps) Theoretical one class per grade enrollment scenario:												
Room	Enrollment					Program				Area m <sup>2</sup>	Room Area m <sup>2</sup>	Formula
	Enrollment	Class Caps	# Classes	# Rooms	Area / p m <sup>2</sup>	Area / p m <sup>2</sup>	Area / p m <sup>2</sup>	# Rooms	Area / p m <sup>2</sup>			
4	28	28	1	1	2.70	75.60	1	75.60	75.60	pop/25p x 2.7sqm/p		
5	28	28	1	1	2.70	75.60	1	75.60	75.60	pop/25p x 2.7sqm/p		
6	28	28	1	1	2.70	75.60	1	75.60	75.60	pop/25p x 2.7sqm/p		
<b>Subtotal</b>	<b>84</b>			<b>3</b>		<b>226.80</b>			<b>226.80</b>			
Contingency		25		1	2.70	67.50		67.50	67.50	total classrooms x .10		
<b>Total</b>						<b>294.30</b>			<b>294.30</b>			
Instructional Resource Room				1		20.00		20.00	20.00	1/200p, 200sqm; min. 1, max 3		
Instructional Resource Suite				1		65.00		65.00	65.00	55sqm - 65sqm		
IRS Washroom				1		9.18		9.18	9.18	1x9, 18sqm		
Science Preparation				1		20.00		20.00	20.00	1 x 20sqm		
Library/Resource				1	0.40	68.60		68.60	68.60	.4sqm /p 1-6 pop; max 200sqm + media lab		
Music				1		78.00		78.00	78.00	1 x 78sqm		
Lunch/Multipurpose				1	1.40	52.92		52.92	62.52	90% pop/2 x 1.4sqm + recycling/vending area		
Kitchen				1		62.00		62.00	62.00	Serving <200p, 62sqm; <250p, 68sqm; <300p, 87; <400p, 100sqm; <500p, 114sqm		
Canteen				1		8.00		8.00	8.00	1 x 8sqm/400p		
Gymnasium				1		389.00		389.00	389.00	<400p, 389sqm; <800p, 588sqm		
Change/Instr/Storage				1		90.00		90.00	90.00	<400p, 90sqm; >400p, 135sqm		
Stage				1		50.00		50.00	50.00	1 x 50sqm		
Administration				1		20.00		20.00	20.00			
Staff / Preparation				1	0.30	43.20		43.20	43.20	<150p, 20sqm; <250p, 25sqm; <600p, 65sqm; <700p, 80sqm; >700p, 90sqm max		
Staff Showers				2		3.50		7.00	7.00	18sqm + .3sqm/p >100p; max 175sqm		
Sick/Washroom				1		15.00		15.00	15.00	2 x 3.5sqm		
Unisex Washroom				1		5.00		5.00	5.00	1 x 15sqm		
Guidance/Itinerant/Wait				3		8.00		24.00	24.00	1x5sqm		
Family Resource Center				0		68.00		0.00	0.00	3 x 8sqm		
Storage				1		10.00		10.00	10.00	68sqm if included		
Utility				1		15.00		15.00	15.00	1sqm/10p		
Lobby				1		40.00		40.00	40.00	1 x 15sqm		
<b>Total</b>									<b>1386.62</b>	.15sqm/p, min 40sqm, max 105sqm		
<b>Grossing Factor</b>								<b>1.50</b>	<b>2079.93</b>			

**Notes:**

Above spatial program analysis demonstrates a theoretical one class per grade enrollment scenario.  
 Potential alternative grade configurations employ similar formula adjusted according to the combination of grades represented.  
 Very small school enrollments employ a spatial allocation specific to the particular circumstances encountered



Standard School Spatial Program Intermediate / Junior High 7-9 (2023 Class Caps) Theoretical one class per grade enrollment scenario:									
Room Grade	Enrollment				Program			Area m <sup>2</sup>	Formula
	Class Caps	# Classes	# Rooms	Area / p	Room Area	Area			
7	31	1.00	1	2.25	69.75	69.75	pop/29p x 2.7sqm/p		
8	31	1.00	1	2.25	69.75	69.75	pop/29p x 2.7sqm/p		
9	31	1.00	1	2.25	69.75	69.75	pop/29p x 2.7sqm/p		
<b>Contingency</b>	<b>93</b>		<b>3</b>	<b>2.25</b>	<b>209.25</b>	<b>209.25</b>	total classrooms x .10		
<b>Total</b>			<b>1</b>	<b>2.25</b>	<b>65.25</b>	<b>65.25</b>			
Instructional Resource Room			1	20.00	20.00	20.00	1/200p;.20sqm; min. 1, max 3		
Instructional Resource Suite			1	65.00	65.00	65.00	55sqm - 65sqm		
IRS Washroom			1	9.18	9.18	9.18	1x9.18sqm		
Science Labs			1	80.00	80.00	80.00	1 x 80sqm/200p		
Library/Resource			1	0.50	81.50	81.50	.5sqm/p; max 200sqm + 35sqm media lab		
Music			1	78.00	78.00	78.00	1 x 78sqm		
Practice			2	6.00	12.00	12.00	2 x 6sqm		
Applied Tech. Fab.			1	120.00	120.00	120.00	<40p;.50sqm ; >40p. 120sqm		
Applied Tech. Design			1	50.00	50.00	50.00	1 x 50sqm		
Computer			1	60.00	60.00	60.00	1/37.5p		
Art			1	90.00	90.00	90.00	1 x 90sqm		
Lunch/Multipurpose			1	1.40	58.59	68.19	90% pop/2 x 1.4sqm + recycling/vending area		
Kitchen			1	62.00	62.00	62.00	Serving <200p;.62sqm; <250p. 68sqm; <300p. 87; <400p. 100sqm; <500p. 114sqm		
Canteen			1	8.00	8.00	8.00	1 x 8sqm/400p		
Home Economics			1	4.60	115.00	115.00	4.6sqm/p; 115sqm max.		
Gymnasium			1	331.00	331.00	331.00	<99p. 331sqm; <180p. 389sqm; <450p. 540sqm; <700p. 609sqm; <900. 686sqm		
Change/Instr/Storage			1	120.00	120.00	120.00	120sqm; >450sqm; 180sqm		
Fitness Center			1	42.00	42.00	42.00	<200p. 42sqm; <500p. 56sqm; <600p. 72sqm; <650p. 90sqm; >650. 108sqm		
Stage			1	50.00	50.00	50.00	1 x 50sqm		
Drama Storage			1	10.00	10.00	10.00	1 x 10sqm		
Administration			1	20.00	20.00	20.00	<150p;.20sqm; <250p;.25sqm; <600p.68sqm; <700p.80sqm; >700p. 90sqm max		
Staff / Preparation			1	0.30	102.90	102.90	75sqm + 3sqm/p >200p; max 200sqm		
Staff Showers			2	3.50	7.00	7.00	2 x 3.5sqm		
Sick/Washroom			1	15.00	15.00	15.00	1 x 15sqm		
Unisex Washroom			1	5.00	5.00	5.00	1x5sqm		
Guidance/Itinerant/Wait			3	8.00	24.00	24.00	3 x 8sqm		
Family Resource Center			0	68.00	0.00	0.00	68sqm if included		
Storage			1	10.00	10.00	10.00	1sqm/10p		
Utility			1	15.00	15.00	15.00	1 x 15sqm		
Lobby			1	40.00	40.00	40.00	.15sqm/p; min 40sqm, max 105sqm		
<b>Total</b>					<b>1985.27</b>	<b>1985.27</b>			
<b>Grossing Factor</b>				<b>1.50</b>		<b>2977.91</b>			

**Notes:**  
 Above spatial program analysis demonstrates a theoretical one class per grade enrollment scenario.  
 Potential alternative grade configurations employ similar formula adjusted according to the combination of grades represented.  
 Very small school enrollments employ a spatial allocation specific to the particular circumstances encountered.



Standard School Spatial Program Grade K-9 (2023 Class Caps)									
Theoretical one class per grade enrollment scenario:									
Room	Program			Area			Formula		
	Enrollment	Class Caps	# Classes	# Rooms	Area / p	Room/Area	Area	Room/Area	Formula
Grade					m <sup>2</sup>	m <sup>2</sup>	m <sup>2</sup>	m <sup>2</sup>	
K*	20	20	1.00	1	2.70	85.00	85.00		85sqm incl. washroom x k/20p/2
1	25	25	1.00	1	2.70	67.50	67.50		pop/25p x 2.7sqm/p
2	25	25	1.00	1	2.70	67.50	67.50		pop/25p x 2.7sqm/p
3	25	25	1.00	1	2.70	67.50	67.50		pop/25p x 2.7sqm/p
4	28	28	1.00	1	2.70	75.60	75.60		pop/28p x 2.7sqm/p
5	28	28	1.00	1	2.70	75.60	75.60		pop/28p x 2.7sqm/p
6	28	28	1.00	1	2.70	75.60	75.60		pop/28p x 2.7sqm/p
7	31	31	1.00	1	2.25	69.75	69.75		pop/29p x 2.7sqm/p
8	31	31	1.00	1	2.25	69.75	69.75		pop/29p x 2.7sqm/p
9	31	31	1.00	1	2.25	69.75	69.75		pop/29p x 2.7sqm/p
<b>Sub Total</b>	<b>272</b>	<b>29</b>	<b>1.00</b>	<b>10</b>	<b>2.25</b>	<b>65.25</b>	<b>723.55</b>		total classrooms x .10
Contingency	29	29	1.00	1	2.25	65.25	65.25		
<b>Classroom Sub Total</b>				<b>11</b>			<b>788.80</b>		
Instructional Resource Room				2		20.00	40.00		1/200p; 20sqm; min. 1, max. 3
Instructional Resource Suite				1		65.00	65.00		55sqm - 65sqm
IRS Washroom				1		9.18	9.18		1x9.18sqm
Science Labs				1		80.00	80.00		1 x 80sqm/200p
Library/Resource				1	0.50	171.00	171.00		.5sqm/p, max 200sqm + 35sqm media lab
Music				1		78.00	78.00		1 x 78sqm
Practice				2	6.00	6.00	12.00		2 x 6sqm
Applied Tech. Fab.				1		120.00	120.00		<40p.60sqm ; >40p. 120sqm
Applied Tech. Design				1		60.00	60.00		1 x 60sqm
Computer				1		60.00	60.00		1/375p
Art				1		90.00	90.00		1 x 90sqm
Lunch/Multipurpose				1	1.40	171.36	192.36		90% pop/2 x 1.4sqm + recycling/vending area
Kitchen				1		100.00	100.00		Serving <200p.62sqm; <250p. 68sqm; <300p. 87; <400p.100sqm; <500p. 114sqm
Canteen				1		8.00	8.00		1 x 8sqm/400p
Home Economics				1	4.60	115.00	115.00		4.6sqm/p; 115sqm max.
Gymnasium				1		540.00	540.00		<99p. 331sqm; <180p. 389sqm; <450p. 540sqm; <700p. 609sqm; <900. 686.25sqm
Change/Instr/Storage				1		120.00	120.00		120sqm; >450sqm. 180sqm
Fitness Center				1		56.00	56.00		<220p. 40sqm; <500p. 56sqm; <600p. 72sqm; <650p. 90sqm; >650. 108sqm
Stage				1		50.00	50.00		1 x 50sqm
Drama Storage				1		10.00	10.00		1 x 10sqm
Administration				1		65.00	65.00		<150p.20sqm; <250p.25sqm; <600p.65sqm; <700p.80sqm; >700p. 90sqm max
Staff /Preparation				1	0.30	156.60	156.60		75sqm + .3sqm/p >200p. max 200sqm
Staff Showers				2		3.50	7.00		2 x 3.5sqm
Sick/Washroom				1		15.00	15.00		1 x 15sqm
Unisex Washroom				1		5.00	5.00		1x5sqm
Guidance/linenent/Wait				3		8.00	24.00		3 x 8sqm
Family Resource Center				0		68.00	0.00		68sqm if included
Storage				1		30.00	30.00		1sqm/10p
Utility				1		15.00	15.00		1 x 15sqm
Lobby				1		40.80	40.80		.15sqm/p; min 40sqm, max 105sqm
<b>Core Spaces Total</b>							<b>2324.94</b>		
<b>Total</b>							<b>3113.74</b>		
<b>Grossing Factor</b>						<b>1.50</b>	<b>4670.61</b>		

**Notes:**  
 Above spatial program analysis demonstrates a theoretical one class per grade enrollment scenario.  
 Potential alternative grade configurations employ similar formula adjusted according to the combination of grades represented.  
 Very small school enrollments employ a spatial allocation specific to the particular circumstances encountered.  
 \*K Cap is raised to 28 where team teaching employed.

Standard School Spatial Program High School LI - LIII [10-12] (2023 Class Caps) Theoretical one class per grade enrollment scenario:									
Room	Program			Area / p	Room Area	Area	Formula	Enrollment	
	Grade	Class Caps	# Classes					# Rooms	Enrollment
10 (Level I)		35	1.00	2.25	78.75	78.75	pop/30p x 2.7sqm/p	1	35
11 (Level II)		35	1.00	2.25	78.75	78.75	pop/30p x 2.7sqm/p	1	35
12 (Level III)		35	1.00	2.25	78.75	78.75	pop/30p x 2.7sqm/p	1	35
<b>SubTotal</b>		<b>105</b>				<b>236.25</b>	total classrooms x .10	<b>3</b>	
<b>Total</b>						<b>315.00</b>			
Instructional Resource Room					20.00	20.00	1/200p, 20sqm; min. 1, max 3	1	
Instructional Resource Suite					65.00	65.00	55sqm - 65sqm	1	
IRS Washroom					9.18	9.18	1x9.18sqm	1	
Science Labs					80.00	80.00	1 x 80sqm/200p	1	
Library/Resource				0.5	87.50	87.50	.5sqm/p; max 200sqm + 35sqm media lab	1	
Music					78.00	78.00	1 x 78sqm	1	
Practice				6	6.00	12.00	2 x 6sqm	2	
Skilled Trades Fab.					120.00	120.00	<40p.50sqm; >40p. 120sqm	1	
Skilled Trades Design					50.00	50.00	1 x 50sqm	1	
Computer					60.00	60.00	1/37.5p	1	
Art					90.00	90.00	1 x 90sqm	1	
Lunch/Multipurpose				1.4	66.15	75.75	90% pop/2 x 1.4sqm + recycling/vending area	1	
Kitchen					62.00	62.00	Serving <200p.62sqm; <300p. 87; <400p.100sqm; <500p. 114sqm	1	
Canteen					8.00	8.00	1 x 8sqm/400p	1	
Home Economics				4.6	115.00	115.00	4.6sqm/p; 115sqm max.	1	
Gymnasium					588.00	588.00	<450p. 588sqm; <650p. 686sqm; >650p. 748sqm	1	
Change/Instir/Storage					120.00	120.00	120sqm; >450sqm, 180sqm	1	
Fitness Center					72.00	72.00	<450p. 72sqm; >450p.108sqm	1	
Stage					50.00	50.00	1 x 50sqm	1	
Drama Storage					10.00	10.00	1 x 10sqm	1	
Administration					20.00	20.00	<150p.20sqm; <250p.25sqm; <600p.65sqm; <700p.80sqm; >700p. 90sqm max	1	
Staff / Preparation				0.5	77.50	77.50	75sqm + 5sqm/p > 150p; max 200sqm	1	
Staff Showers					3.50	7.00	2 x 3.5sqm	2	
Sick/Washroom					15.00	15.00	1 x 15sqm	1	
Unisex Washroom					5.00	5.00	1x5sqm	1	
Guidance/timerent/Wait					8.00	24.00	3 x 8sqm	3	
Family Resource Center					68.00	0.00	68sqm if included	0	
Storage					20.00	20.00	1sqm/10p	1	
Utility					15.00	15.00	1 x 15sqm	1	
Lobby					40.00	40.00	.15sqm/p; min 40sqm, max 105sqm	1	
<b>Total</b>						<b>2310.93</b>			
<b>Grossing Factor</b>					<b>1.50</b>	<b>3466.40</b>			

**Notes:**

Above spatial program analysis demonstrates a theoretical one class per grade enrollment scenario.  
 Potential alternative grade configurations employ similar formula adjusted according to the combination of grades represented.  
 Very small school enrollments employ a spatial allocation specific to the particular circumstances encountered.

Standard School Spatial Program All Grade K-12 (2023 Class Caps) Theoretical one class per grade enrollment scenario:										
Room	Program				Program			Room/Area m <sup>2</sup>	Area m <sup>2</sup>	Formula
	Enrollment	Class Caps	# Classes	# Rooms	Area / p m <sup>2</sup>	# Rooms	Area / p m <sup>2</sup>			
Grade										
K*	20	20	1.00	1	2.70	1	85.00	85.00	85sqm incl. washroom x k/20p/2	
1	25	25	1.00	1	2.70	1	67.50	67.50	pop/25p x 2.7sqm/p	
2	25	25	1.00	1	2.70	1	67.50	67.50	pop/25p x 2.7sqm/p	
3	25	25	1.00	1	2.70	1	67.50	67.50	pop/25p x 2.7sqm/p	
4	28	28	1.00	1	2.70	1	75.60	75.60	pop/26p x 2.7sqm/p	
5	28	28	1.00	1	2.70	1	75.60	75.60	pop/26p x 2.7sqm/p	
6	31	31	1.00	1	2.25	1	69.75	69.75	pop/29p x 2.7sqm/p	
7	31	31	1.00	1	2.25	1	69.75	69.75	pop/29p x 2.7sqm/p	
8	31	31	1.00	1	2.25	1	69.75	69.75	pop/29p x 2.7sqm/p	
9	35	35	1.00	1	2.25	1	78.75	78.75	pop/30p x 2.7sqm/p	
10 (Level I)	35	35	1.00	1	2.25	1	78.75	78.75	pop/30p x 2.7sqm/p	
11 (Level II)	35	35	1.00	1	2.25	1	78.75	78.75	pop/30p x 2.7sqm/p	
12 (Level III)	35	35	1.00	1	2.25	1	78.75	78.75	pop/30p x 2.7sqm/p	
<b>SubTotal</b>	<b>377</b>			<b>13</b>			<b>959.80</b>		total classrooms x .10	
Contingency		35		2	2.25		78.75	157.50		
<b>Classroom SubTotal</b>				<b>15</b>			<b>1117.30</b>			
Instructional Resource Room				2			20.00	40.00	1/200p; 20sqm; min. 1, max 3	
Instructional Resource Suite				1			65.00	65.00	55sqm - 65sqm	
IRS Washroom				1			9.18	9.18	1x9.18sqm	
Science Labs				1			80.00	80.00	1 x 80sqm/200p	
Library/Resource				1	0.50		223.50	223.50	.5sqm/p; max 200sqm + 35sqm media lab	
Music				1			78.00	78.00	1 x 78sqm	
Pradice				2	6.00		6.00	12.00	2 x 6sqm	
Skilled Trades Fab.				1			120.00	120.00	<40p; 50sqm ; >40p, 120sqm	
Skilled Trades Design				1			50.00	50.00	1 x 50sqm >40p; <40p, 0	
Computer				1			60.00	60.00	1 x 60sqm / 375p	
Art				1			90.00	90.00	1 x 90sqm	
Lunch/Multipurpose				1	1.40		237.51	260.51	90% pop/2 x 1.4sqm + recycling/vending area	
Kitchen				1			114.00	114.00	Serving ~200p; 62sqm; <250p, 68sqm; <300p, 87; <400p; 100sqm; <500p, 114sqm	
Canteen				1			8.00	8.00	1 x 8sqm/400p	
Home Economics				1	4.60		115.00	115.00	4.6sqm/p; 115sqm max	
Gymnasium				1			588.00	588.00	<450p, 588sqm; <650p, 686sqm; >650p, 748sqm	
Change/Instr/Storage				1			120.00	120.00	120sqm; >450sqm, 180sqm	
Fitness Center				1			56.00	56.00	<200p, 42sqm; <500p, 56sqm; <600p, 72sqm; <650p, 90sqm; >650, 108sqm	
Stage				1			50.00	50.00	1 x 50sqm	
Drama Storage				1			10.00	10.00	1 x 10sqm	
Administration				1			65.00	65.00	<150p; 20sqm; <250p; 25sqm; <600p; 65sqm; <700p; 80sqm; >700p, 90sqm max	
Staff / Preparation				1	0.50		213.50	213.50	75sqm + 5sqm/p >150p; max 200sqm	
Staff Showers				2			3.50	7.00	2 x 3.5sqm	
Sick/Washroom				1			15.00	15.00	1 x 15sqm	
Unisex Washroom				1			5.00	5.00	1x5sqm	
Guidance/Inherent/Wait				3			8.00	24.00	3 x 8sqm	
Family Resource Center				0			68.00	0.00	68sqm if included	
Storage				1			40.00	40.00	1sqm/10p	
Utility				1			15.00	15.00	1 x 15sqm	
Lobby				1			56.55	56.55	.15sqm/p; min 40sqm, max 105sqm	
<b>Core Spaces SubTotal</b>								<b>2590.24</b>		
<b>Total</b>								<b>3707.54</b>		
<b>Grossing Factor</b>							<b>1.50</b>	<b>5561.31</b>		

**Notes:**  
Above spatial program analysis demonstrates a theoretical one class per grade enrollment scenario.  
Potential alternative grade configurations employ similar formula adjusted according to the combination of grades represented.  
Very small school enrollments employ a spatial allocation specific to the particular circumstances encountered.  
\*K, Cap is raised to 28 where team teaching employed.