



Universal Design Standard - 2021

Department of Transportation and Infrastructure

TABLE OF CONTENTS

| | | |
|--------|---|----|
| 1.0 | INTRODUCTION..... | 1 |
| 2.0 | DEFINITIONS..... | 4 |
| 3.0 | SCOPE AND APPLICATION..... | 10 |
| 3.1 | General Application..... | 10 |
| 3.2 | Application Based on Facility Use..... | 10 |
| 3.3 | Work Areas and Employee-Designated Areas..... | 10 |
| 3.4 | Temporary Facilities..... | 11 |
| 3.5 | Retrofitting, Alterations and Additions..... | 11 |
| 3.6 | Equivalent Facilitation..... | 12 |
| 3.7 | Implementation..... | 12 |
| 3.8 | Enforcement..... | 12 |
| 4.0 | PHYSICAL ACCESSIBILITY..... | 13 |
| 4.1 | Access and Circulation..... | 13 |
| 4.1.1 | Space and Reach Requirements..... | 13 |
| 4.1.2 | Protruding and Overhead Objects..... | 17 |
| 4.1.3 | Accessible Routes, Paths and Corridors..... | 19 |
| 4.1.4 | Ground and Floor Surfaces..... | 22 |
| 4.1.5 | Entrances..... | 24 |
| 4.1.6 | Exterior Pedestrian Routes..... | 25 |
| 4.1.7 | Vehicular Access..... | 28 |
| 4.1.8 | Doors..... | 31 |
| 4.1.9 | Gates, Turnstiles and Openings..... | 38 |
| 4.1.10 | Ramps..... | 40 |
| 4.1.11 | Stairs..... | 45 |
| 4.1.12 | Handrails..... | 47 |
| 4.1.13 | Elevators..... | 51 |
| 4.1.14 | Platform Lifts..... | 55 |
| 4.2 | Washroom Facilities..... | 57 |
| 4.2.1 | Toilet and Bath Facilities..... | 57 |

TABLE OF CONTENTS

| | | |
|--------|---|-----|
| 4.2.2 | Toilet Stalls | 60 |
| 4.2.3 | Toilets | 63 |
| 4.2.4 | Lavatories | 65 |
| 4.2.5 | Urinals | 68 |
| 4.2.6 | Washroom Accessories | 70 |
| 4.2.7 | Universal Washrooms..... | 73 |
| 4.2.8 | Bathtubs | 76 |
| 4.2.9 | Shower Stalls..... | 78 |
| 4.2.10 | Grab Bars | 81 |
| 4.3 | Amenities | 83 |
| 4.3.1 | Drinking Fountains..... | 83 |
| 4.3.2 | Public Telephones | 85 |
| 4.3.3 | Information, Reception and Service Counters | 88 |
| 4.3.4 | Offices, Work Areas and Meeting Rooms..... | 90 |
| 4.3.5 | Tables, Counters and Work Surfaces..... | 91 |
| 4.3.6 | Lockers and Storage Units | 93 |
| 4.3.7 | Storage, Shelving and Display Units | 94 |
| 4.3.8 | Elevated Platforms | 96 |
| 4.3.9 | Kitchens and Kitchenettes | 98 |
| 4.3.10 | Landscaping Materials and Planting..... | 103 |
| 4.3.11 | Benches..... | 104 |
| 4.3.12 | Waiting and Queuing Areas..... | 106 |
| 4.4 | Systems and Controls | 107 |
| 4.4.1 | Controls and Operating Mechanisms | 107 |
| 4.4.2 | Emergency Exits, Fire Evacuation and Areas of Rescue Assistance | 110 |
| 4.4.3 | Card Access, Safety and Security Systems..... | 113 |
| 5.0 | VISUAL ACCESSIBILITY | 115 |
| 5.1 | Glare and Light Sources | 115 |
| 5.2 | Lighting | 116 |
| 5.3 | Texture and Colour | 118 |

TABLE OF CONTENTS

| | | |
|-----|---|-----|
| 5.4 | Materials and Finishes | 120 |
| 5.5 | Information Systems | 121 |
| 5.6 | Signage | 123 |
| 5.7 | Tactile Walking Indicator Surfaces | 127 |
| 5.8 | Windows, Glazed Screens and Sidelights..... | 131 |
| 6.0 | AUDIBLE ACCESSIBILITY | 133 |
| 6.1 | Acoustics..... | 133 |
| 6.2 | Audible Signal | 134 |
| 6.3 | Visual Alarms | 135 |
| 6.4 | Public Address Systems | 136 |
| 6.5 | Assistive Listening Systems | 137 |
| 7.0 | FACILITY SPECIFIC REQUIREMENTS | 138 |
| 7.1 | Meeting Rooms, Assembly Areas and Theatres | 138 |
| 7.2 | Displays, Exhibition Areas, Galleries and Museums | 141 |
| 7.3 | Cafeterias..... | 142 |
| 7.4 | Libraries | 144 |
| 7.5 | Courts | 147 |
| 7.6 | Gymnasiums | 149 |
| 8.0 | ACKNOWLEDGEMENTS..... | 151 |

1.0 INTRODUCTION

This universal design standard addresses accessibility requirements for the design and construction of new **facilities**, as well as the **retrofit, alteration** or **addition** to existing **facilities**, owned, leased or operated by the Government of Newfoundland and Labrador. This document addresses a diverse range of user needs, including people with **disabilities**. It embraces the spirit of universal design through the creation of inclusive environments.

This universal design standard incorporates the principle of universal design that recognizes the broad diversity of people who use **facilities**. Universal design is defined as: “The design of products and environments to be usable by all people, to the greatest extent possible, without the need for adaptation or specialized design” (Mace, R., 1983). The universal design philosophy is structured around the following seven design principles:

1. Equitable Use:

The design is useful and marketable to people with diverse abilities.

2. Flexibility In Use:

The design accommodates a wide range of individual preferences and abilities.

3. Simple And Intuitive Use:

Use of the design is easy to understand, regardless of the user’s experience, knowledge, language skills, or current concentration level.

4. Perceptible Information:

The design communicates necessary information effectively to the user, regardless of ambient conditions or the user’s sensory abilities.

5. Tolerance For Error:

The design minimizes hazards and the adverse consequences of accidental or unintended actions

6. Low Physical Effort:

The design can be used efficiently and comfortably with a minimum of fatigue.

7. Size and Space For Approach And Use:

Appropriate size and space are provided for approach, reach, manipulation and use, regardless of user’s body position, size, posture or mobility.

“The Principles of Universal Design, NC State University, The Centre for Universal Design” ©

This universal design standard reflects minimum dimensional criteria required for adult persons. Prior to the design stage of a project, consideration should be

given to the function of the **facility** and the people who will use it. A review and upgrade of the design standards presented in this manual may be required in some instances, particularly if a **facility** is designed primarily for the use of a particular type of user, such as children or older persons.

Where conflicts exist between scoping and/or dimensional requirements of this design standard and standards or legislation enacted by the federal or provincial governments, the most accommodating requirements shall apply (i.e. the requirement(s) that will result in the most accommodating environment, but never less than the minimum requirements of the National Building Code of Canada), provided federal or provincial approvals are obtained where required.

The Department of Transportation and Infrastructure shall review and/or update this **universal** design standard every 3-5 years, or as deemed necessary to reflect user feedback, technological advancement and new construction practices, as well as changes to the barrier-free design requirements of various codes and standards such as the National Building Code of Canada and the CSA Standard B651 – “Accessible Design for the Built Environment”.

This universal design standard recognizes the concept of equivalent facilitation as a means to encourage new and innovative design ideas and solutions. Departures from particular technical and scoping requirements of this standard through the use of other designs and technologies is encouraged, when the alternatives will provide substantially equivalent or greater access to the usability of the **element** and/or **facility**. Design departures from information provided and referenced in this standard should be carefully assessed to determine the validity of the application and may require review by a committee appointed for this purpose by the Department of Transportation and Infrastructure.

Dimensions used in this standard are in metric units.

For purposes of this standard, words and terms in **highlighted in RED** have their meanings defined in **Section 2.0 Definitions**.

The Department of Transportation and Infrastructure encourages all users of this universal design standard to provide feedback, as well as proposals for changes, additions and/or deletions.

Other municipalities are welcomed and encouraged to utilize this universal design standard.

2.0 DEFINITIONS

Access Aisle

An **accessible** pedestrian space between **elements**, such as parking spaces, seating and desks, that provides clearances appropriate for the use of the **elements**.

Accessible

Describes a **site, building, facility**, or portion thereof that complies with the requirements of this design standard.

Accessible Element

An **element** specified by this manual (for example, telephone, controls etc.).

Accessible Route

A continuous unobstructed path connecting **accessible elements** and **spaces** of a **facility**. Interior **accessible routes** may include corridors, floors, **ramps**, elevators, platform lifts and **clear spaces** at fixtures. Exterior **accessible routes** may include parking **access aisles, curb ramps**, crosswalks at **vehicular ways, walks, ramps** and platform lifts.

Accessible Space

Space that complies with the requirements of this design standard.

Adaptable

The ability of a certain **building space** or **element**, such as kitchen counters, sinks, and grab bars, to be added or altered so as to accommodate the needs of individuals with or without disabilities or to accommodate the needs of persons with different types or degrees of disabilities.

Adaptive Seating

A fixed seat or seats designed to facilitate a side transfer from a wheeled mobility device.

Addition

An expansion, extension, or increase in the gross floor area of a **facility**.

Alteration

A change to a **facility**, including a change of use, that affects or could affect the usability of the **facility** or part thereof. **Alterations** include, but are not limited to, remodeling, renovation, **retrofitting**, rehabilitation, reconstruction, historic restoration, resurfacing of **circulation paths** or **vehicular ways**, changes or rearrangement of the structural parts or **elements**, and changes or rearrangement in the plan configuration of walls and full-height partitions. Normal maintenance, painting or wallpapering, or changes to mechanical or electrical systems are not **alterations**, unless they affect the usability of the **building**.

Area of Rescue Assistance

An area which has direct access to an exit, where people who are unable to use stairs may remain temporarily in safety to await further instructions or assistance during emergency evacuation.

Assembly Area

A room or **space** accommodating a group of individuals for recreational, educational, political, social, civic or amusement purposes, or for the consumption of food and drink.

Assistive Listening Device

Equipment used to receive sound output from the **Assistive Listening System**.

Assistive Listening Systems

Wireless sound transmission systems that improve sound reception for persons with hearing disabilities by providing amplification which can be adjusted by each user while blocking out unwanted background noise.

Automatic Door

A door equipped with a power-operated mechanism and controls that open and close the door automatically upon receipt of a momentary actuating signal. The switch that begins the automatic cycle may be a photoelectric device, floor mat, or manual switch. (See **Power Operated Door**).

Braille

A system where raised dots are used to represent letters and words. Unified English **Braille** (UEB) is the **braille** standard for Canada.

Building

Any structure used or intended for supporting or sheltering any use or occupancy.

Cane-Detectable

Within the detection range of a cane as it sweeps or taps.

Circulation Path

An exterior or interior way of passage from one place to another for pedestrians, including, **walks**, hallways, courtyards, stairways, stair landings, platforms and stages.

Clear Path of Travel

An exterior or interior way of passage from one place to another for pedestrians, including, **walks**, hallways, courtyards, stairways, and stair landings.

Clear Floor Space

The minimum unobstructed floor or ground **space** required to accommodate a single, stationary wheelchair, scooter or other mobility device, including the user.

Closed-Circuit Telephone

A telephone with dedicated line (s), such as a house phone, courtesy phone or phone that must be used to gain **entrance** to a **facility**.

Colour Contrast

A significant contrast in colour between the foreground and background of an **element**, e.g., light on a dark background or dark on light background.

Common Use

Refers to those interior and exterior rooms, **spaces** or **elements** that are made available for use by groups of people (for example, the occupants of an office building, or the guests of such occupants).

Cross Slope

The slope that is perpendicular to the direction of travel. (See **ramp slope**)

Curb Ramp

A short **ramp** cutting through a curb or built up to a curb.

Detectable Warning

A standardized surface feature built into or applied to walking surfaces or other **elements** to warn persons who are blind or partially sighted of hazards on a **circulation path**.

Disability

A physical, mental, intellectual, learning, communication or sensory limitation – or a functional limitation – whether permanent, temporary or episodic in nature, that, in interaction with a barrier, hinders a person’s full and equal participation in society. The experience of disability can be minimized by designing environments to accommodate a range of physical and sensory capabilities.

Egress, Means of

A continuous and unobstructed way of exit travel from any point in a **facility** to a public right-of-way. A **means of egress** comprises vertical and horizontal travel and may include intervening room **spaces**, doorways, hallways, corridors, passageways, balconies, **ramps**, stairs, enclosures, lobbies, horizontal exits, courts and yards. An **accessible means of egress** is one that complies with the design requirements of this standard and does not include stairs, steps or escalators. Areas of rescue assistance, protected lobbies or protected elevators may be included as part of an **accessible means of egress**.

Element

An architectural, mechanical or electrical component of a **building, facility, space** or **site** (e.g., telephone, **curb ramp**, door, drinking fountain, seating or water closet).

Entrance

Any access point into a **building** or a **facility** used for the purposes of entering. An **entrance** includes the approach **walk**, the vertical access leading to the **entrance** platform, the **entrance** platform itself, vestibules (if provided), the entry door(s) or gate(s), and the hardware of the entry door(s) or gate(s).

Facility or Facilities

All or any portion of **buildings**, structures, site improvements, complexes, equipment, roads, **walks**, passageways, parking lots or other real or personal property located on a **site**.

Ground Floor

Any occupiable floor less than one **storey** above or below grade with direct access to grade. A **facility** always has at least one **ground floor** and may have more than one **ground floor**, as where a split-level **entrance** has been provided or where a **facility** is built into a hillside.

Guard

A safety railing used as a barrier to prevent encroachment or accidental falling from heights.

Handrail

A component which is normally grasped by hand for support at stairways and other places where needed for safety of pedestrians.

Indicator Surface

A ground surface that is in **colour contrast** to an adjacent **accessible route**, as well as textured differently to the surface of the **accessible route** to be **cane-detectable** and detectable under foot.

Marked Crossing

A crosswalk or other identified path intended for pedestrian use in crossing a **vehicular way**.

Mezzanine or Mezzanine Floor

An intermediate floor assembly between the floor and ceiling of any room or **storey** and includes an interior balcony.

Operable Portion

A part of a piece of equipment or appliance used to insert or with-draw objects, or to activate, deactivate, or adjust the equipment or appliance (for example, coin slot, push button, handle).

Power Operated Door

A door used for human passage that has a mechanism that helps to open the door or relieves the opening resistance of a door, upon the activation of a switch or push button.

Ramp

A walking surface which has a **ramp slope** greater than 1:20.

Ramp Slope

The slope of a **ramp** that is parallel to the direction of travel. (See Cross Slope).

Service Entrance

An **entrance** intended primarily for delivery of goods or services and access by staff, not intended for use by the public.

Service Room

A room provided in a **building** to contain equipment and to perform activities associated with **building** services.

Service Space

A space provided in a **facility** to facilitate or conceal the installation of **facility** items such as chutes, ducts, pipes, shafts or wires.

Signage

Displayed of written word, symbols, pictorial, **tactile** and contracted **Braille** information.

Space

A definable area (e.g. room, toilet room, hall, assembly area, **entrance**, dormitory, storage room, alcove, courtyard or lobby).

Storey

That portion of a **building** that is situated between the top of any floor and the top of the floor next above it, and if there is no floor above it, that portion between the top of such floor and the ceiling above it.

Tactile

Describes an object that can be perceived using the sense of touch.

Tactile Walking Surface Indicator (TWSI)

A standardized surface, detectable underfoot and cane-detectable, to assist persons with low or on vision by alerting or guiding them.

Tactile Attention Indicator

A TWSI comprising of truncated domes that signals a need for caution at a change in elevation, a vehicular route or other potential hazard.

Tactile Direction Indicator

A TWSI that uses flat-topped elongated bars to facilitate wayfinding in open areas.

Telephone Typewriter (TTY)

Telephone equipment that employs interactive text-based communication through the transmission of text across the standard telephone network.

Truncated Domes

Small domes with flattened tops that are inset into paving as **tactile** warnings at transit platforms, curb edges, and other potential hazards.

Vehicular Way

A route intended for vehicular traffic, such as a street, driveway or parking lot.

Walk

An exterior pathway with a prepared surface intended for pedestrian use, including general pedestrian areas, such as plazas and courts.

Wayfinding

A term used to describe the spatial problem-solving process that a person uses to reach a destination. A mental 'map' is formed of the overall setting and the desired destination. This map is based on information obtained from orientation cues that are available from the setting's environment. These cues include not only **signage**, but also overall spatial forms, structures, sounds, surface textures, colours, illumination levels, architectural features, etc. **Wayfinding** cues should reduce complexity and increase consistency in an environment.

3.0 SCOPE AND APPLICATION

3.1 General Application

- 1) The requirements of this standard shall be:
 - a) Mandatory for all newly constructed and retrofitted **facilities** owned, leased or operated by the member organization of the Government of Newfoundland and Labrador, and
 - b) Encouraged for all other **facilities**, whether new or retrofitted.
- 2) This standard does not apply to:
 - a) Residential occupancies,
 - b) **Buildings** of Group F Division 1 occupancy, as defined by the National Building Code of Canada, and
 - c) **Buildings** which are not intended to be occupied as a place of daily or full-time activity including but not limited to automatic telephone exchanges, pump houses, sewage treatment, storage buildings, salt sheds and water treatment facilities and substations.
- 3) All areas of newly designed or newly constructed **facilities** and altered portions of existing **facilities** shall comply with this standard, unless otherwise provided in this section or as modified in **Sections 4.1 Access and Circulation, 4.2 Washroom Facilities, 4.3 Amenities and 4.4 Systems and Controls**, or as modified in **Section 7.0 Facility Specific Requirements**.

Exceptions: The requirements of **Sections 4.1 to 4.4** do not apply to:

- **Service Rooms**
- Elevator machine rooms
- Janitor rooms
- **Service spaces**
- Crawl spaces
- Attic or roof spaces

3.2 Application Based on Facility Use

- 1) The specific **facility** types listed in **Section 7.0 Facility Specific Requirements**, shall comply with the provisions specified throughout the entire standard, where applicable.
- 2) Where a **facility** contains more than one use covered by a special application section, each portion shall comply with the requirements for that section in addition to all other general provisions.

3.3 Work Areas and Employee-Designated Areas

- 1) All **facilities** shall be **accessible** for employees, as well as patrons/users. All areas intended for use by employees shall be designed and constructed to comply with this standard, including access through doors into all offices.

3.4 Temporary Facilities

- 1) This standard applies to temporary **facilities**, as well as permanent **facilities**.

3.5 Retrofitting, Alterations and Additions

- 1) Each **addition** to an existing **facility** shall be regarded as an **alteration**.
- 2) Each **space** or **element** added to the existing **facility** shall comply with the applicable provision(s) of this standard.
- 3) Except where the provision of **accessible** features is technically infeasible, no **alteration** shall decrease or have the effect of decreasing **accessibility** or usability of an existing **facility** to below the requirements for new construction at the time of **alteration**.
- 4) If existing **elements**, **spaces** or common areas are altered, then each such altered **element/space**/feature/area shall comply with all applicable provisions.
- 5) If the applicable provision for new construction requires that an **element/space**/feature/area be on an **accessible route** and the altered **element/space**/feature/area is not on an **accessible route**, this route shall be altered to become **accessible**.
- 6) If **alterations** of single **elements**, when considered together, amount to an **alteration** of a room or **space** in a **facility**, the entire **space** shall be made **accessible**.
- 7) No **alteration** of an existing **element**, **space** or area of a **facility** shall impose a requirement for greater **accessibility** than that which would be required for new construction.
- 8) If an escalator or stairs are proposed as a means of access where none existed previously, and major structural modifications are necessary for such installations, then a means of **accessible** access shall also be provided.
- 9) If a planned **alteration** entails **alterations** to an **entrance**, and the **facility** has an **accessible entrance**, the **entrance** being altered is required to be **accessible**.
- 10) If the **alteration** work is limited solely to the electrical, mechanical or plumbing system, or to hazardous material abatement, or to automatic sprinkler retrofitting, and does not involve the **alteration** of any **elements** or **spaces** required to be **accessible** under these guidelines, then this standard does not apply (except for alarms, public telephones and **assistive listening systems**).
- 11) An **alteration** that affects the usability of or access to an area containing a primary function shall be made to ensure that, to the maximum extent feasible, the path of travel to the altered area, the washrooms, telephones

- and drinking fountains serving the altered area are readily **accessible** to and usable by individuals with disabilities.
- 12) Where the provision of **accessible** features is technically infeasible, and the standard allows a reduction of maneuvering **space** from the requirements for new construction, the reduced dimensions are minimums. Where possible, larger maneuvering **spaces** must be provided.

3.6 Equivalent Facilitation

- 1) Equivalent facilitation proposals shall be submitted for review and approval on an individual basis.

3.7 Implementation

- 1) The Department of Transportation and Infrastructure, other Government of Newfoundland and Labrador departments, as well as contracted consulting firms, design-build contractors, shall be responsible for the application of The Department of Transportation and Infrastructure Universal Design Standards when designing and administering all construction and renovation projects associated with new **facilities**, as well as retrofit, **alteration** or **addition** to existing **facilities** owned, leased or operated by the Government of Newfoundland and Labrador.
- 2) Designing and constructing to this standard shall be included as a mandatory requirement in all Government of Newfoundland and Labrador, Department of Transportation and Infrastructure Request for Proposals, Tender Documents and construction Contracts.

3.8 Enforcement

- 1) The Department of Transportation and Infrastructure, and other Government of Newfoundland and Labrador departments, through the project management function, shall ensure compliance to this standard during the pre-planning, design, construction documents preparation and contract administration phase.

4.0 PHYSICAL ACCESSIBILITY

4.1 Access and Circulation

4.1.1 Space and Reach Requirements

Space and reach range provisions for persons who use wheelchairs, scooters and other mobility devices shall comply with the following:

- 1) **Space** for a wheel chair to make a 360° turn: 1930 mm – **Figure 4.1.1 (a)**, or for a 180° turn, as shown in **Figure 4.1.1 (b)**.
- 2) Minimum **clear floor** or ground **space** required to accommodate a single wheelchair or scooter and occupant shall be at least:
 - a) 800 mm x 1370 mm for a stationary position, and
 - b) 1930 mm x 1930 mm for a U-Turn – **Figures 4.1.1 (c), 4.1.1 (d) and 4.1.1 (a)**.
- 3) The minimum **clear floor** or ground **space** for wheelchairs or scooters may be positioned for forward or parallel approach to an object.
- 4) **Clear floor** or ground **space** for wheelchairs may be part of the knee **space** required under some objects.
- 5) One full, unobstructed side of the **clear floor** or ground **space** for a wheelchair or scooter shall adjoin or overlap an **accessible route** or adjoin another wheelchair **clear floor space**. If a **clear space** is located in an alcove or otherwise confined on all or part of three sides, additional maneuvering clearances shall be provided – **Figures 4.1.1 (e), 4.1.1 (f), 4.1.1 (g) and 4.1.1 (h)**.
- 6) If the **clear floor space** only allows a forward approach to an object, the maximum high forward reach allowed shall be 1200 mm. The maximum low forward reach is 400 mm - **Figure 4.1.1 (i)**. If the high forward reach is over an obstruction, reach and clearances shall be as shown in **Figures 4.1.1 (j) and 4.1.1 (k)**.
- 7) If the **clear floor space** allows parallel approach to an object, the maximum high side reach allowed shall be 1370 mm and the low side reach no less than 230 mm above the floor – **Figure 4.1.1 (l) and 4.1.1 (n)**. If the side reach is over an obstruction, reach and clearances shall be as shown in **Figure 4.1.1 (m)**.
- 8) Notwithstanding these requirements, the National Building Code requires all controls for the operation of facility services or safety devices, including electrical switches, thermostats and intercom switches, be mounted at not more than 1200 mm above the floor.

Note: In **Figures 4.1.1 (j) and 4.1.1 (k)**, X shall be less than or equal to 635 mm: Z shall be greater than or equal to X.

When X is less than 510 mm, then Y shall be 1220 mm maximum.

When X is 510 to 635 mm, then Y shall be 1120 mm maximum.

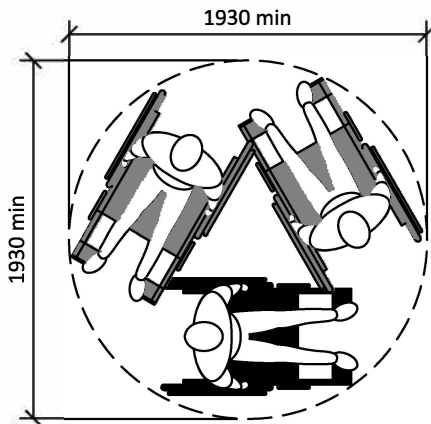

Figure 4.1.1 (a) - 360° Turning Space

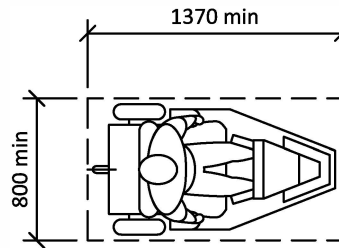

Figure 4.1.1 (d) - Clear Space for Scooter

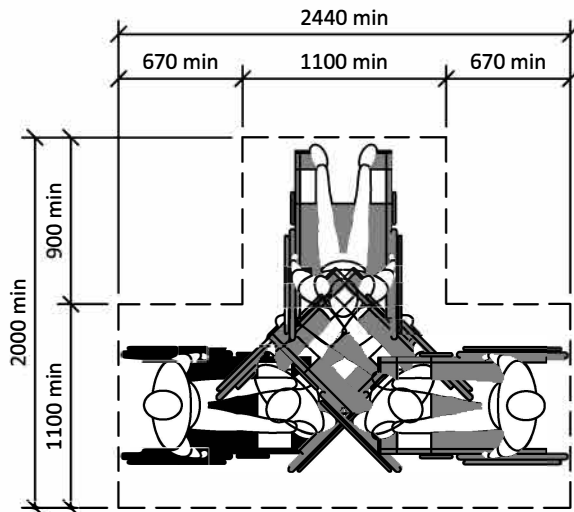
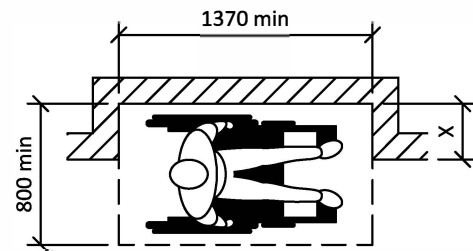

Figure 4.1.1 (b) - 180° Turning Space



Parallel Approach - where X is 380 mm or less.

Figure 4.1.1 (e) - Clearances at Alcove

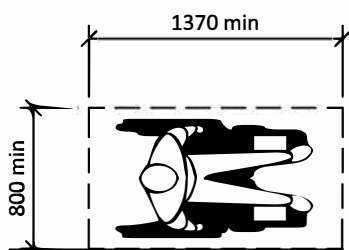
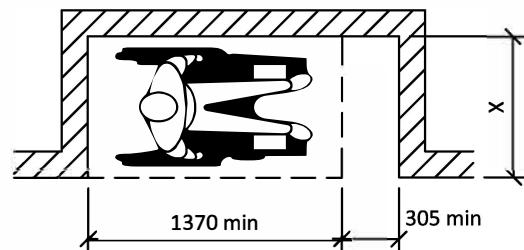
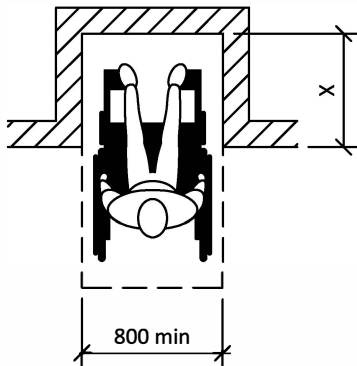

Figure 4.1.1 (c) - Clear Floor Space for Wheelchair



Parallel Approach - where X is more than 380 mm.

Figure 4.1.1 (f) - Clearances at Alcove



Frontal Approach - where X is 610 mm or less.

Figure 4.1.1 (g) - Clearances at Alcove

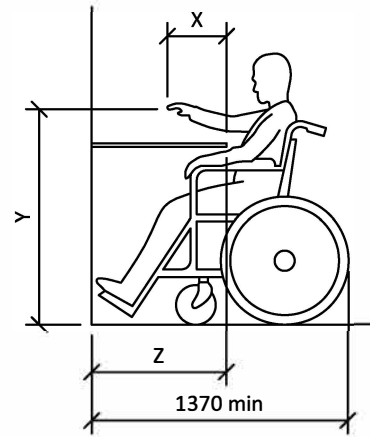
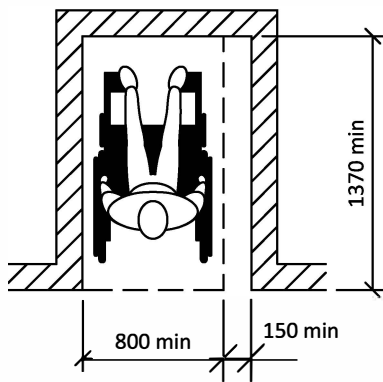

Figure 4.1.1 (j) - Forward Reach over an Obstruction



Frontal Approach - where X is more than 610 mm.

Figure 4.1.1 (h) - Clearances at Alcove

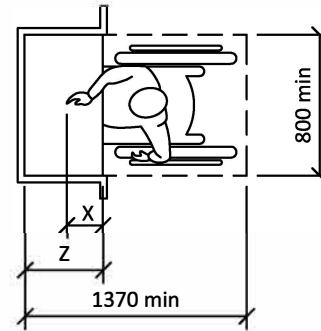

Figure 4.1.1 (k) - Forward Reach over an Obstruction

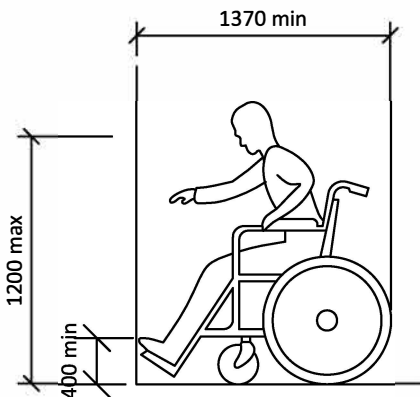

Figure 4.1.1 (i) - Forward Reach

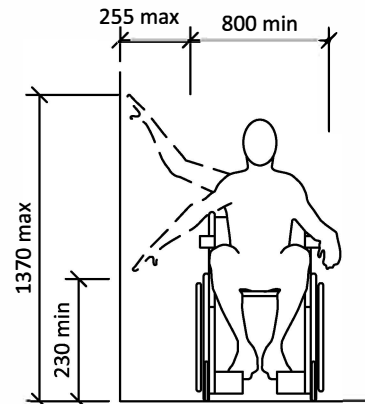

Figure 4.1.1 (l) - Side Reach

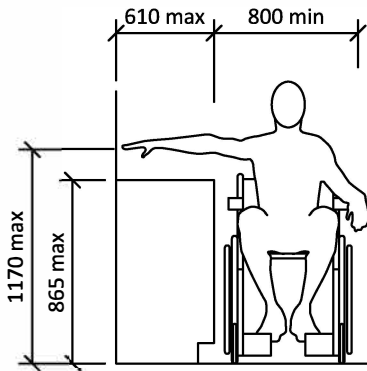

Figure 4.1.1 (m) - Side Reach over an Obstruction

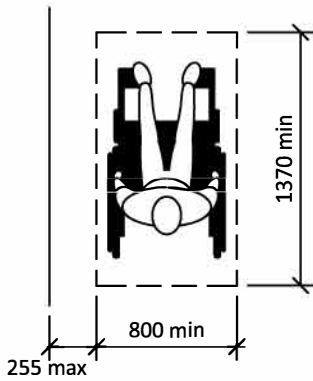

Figure 4.1.1 (n) - Side Reach - Maximum Distance to Wheelchair

4.1.2 Protruding and Overhead Objects

- 1) Objects protruding from walls with their leading edges between 685 mm and 2100 mm from the floor shall protrude not more than 100 mm into pedestrian areas, such as walkways, halls, corridors, passageways or aisles – **Figure 4.1.2 (a)**.
- 2) Objects attached to a wall with their leading edges at or below 685 mm from the floor may protrude any amount – **Figure 4.1.2 (b)**.
- 3) Freestanding objects shall not have any overhang of more than 305 mm between 685 mm and 2100 mm from the ground or floor.
- 4) The maximum height of the bottom edge of freestanding objects with a **space** of more than 305 mm between supports shall be 685 mm from the ground or floor.
- 5) Protruding objects shall not reduce the clear width required for an **accessible route** or maneuvering **space** – **Figure 4.1.2 (b)**.
- 6) The minimum clear headroom in pedestrian areas, such as walkways, halls, corridors, passageways or aisles shall be 2100 mm – **Figure 4.1.2 (c)**.
- 7) A detectable **guard**, guardrail or other barrier having its leading edge at or below 685 mm from the floor shall be provided where the headroom of an area adjoining an **accessible route** is reduced to less than 2100 mm - **Figure 4.1.2 (c)**.

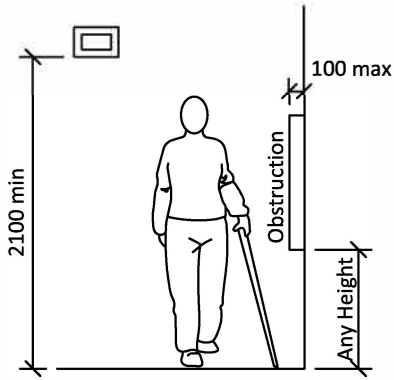
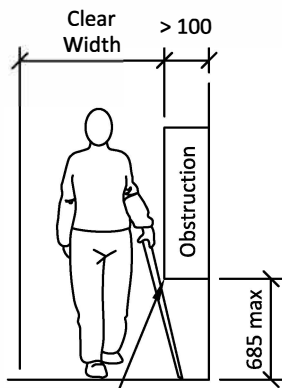

Figure - 4.1.2 (a) - Limits of Protruding Objects



Cane hits obstruction

Figure 4.1.2 (b) - Limits of Protruding Objects

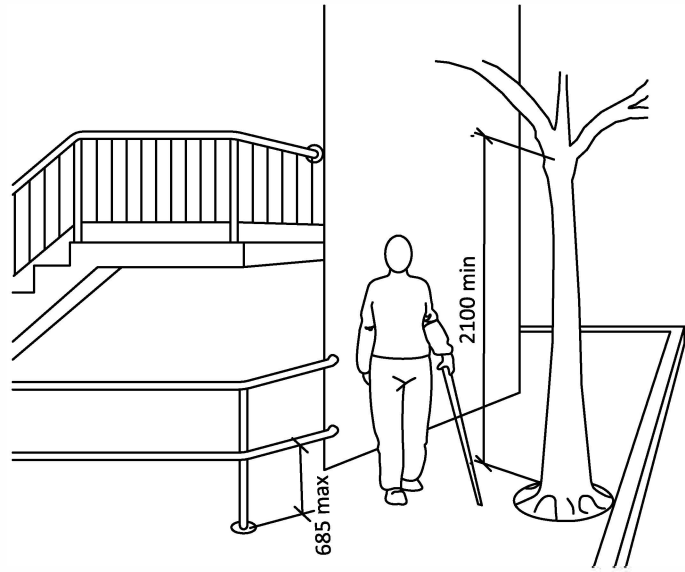

Figure 4.1.2 (c) - Overhead Obstructions

4.1.3 Accessible Routes, Paths and Corridors

- 1) Wherever possible, all routes, paths or corridors shall comply with this section.
- 2) **Accessible routes** shall comply with this section.
- 3) Within a given site, at least one **accessible route** shall be provided to an **accessible entrance**.
- 4) An **accessible route** shall interconnect all **accessible entrances**, all **accessible spaces** and **accessible elements** within a **facility**, except where such a route would be hazardous.
- 5) An **accessible route** shall be provided within all occupiable floor areas, except to:
 - a) **Services rooms**.
 - b) Elevator machine rooms.
 - c) Janitor Rooms.
 - d) **Services spaces**.
 - e) Crawl spaces.
 - f) Attic or roof spaces.
 - g) High hazard industrial occupancies.
 - h) Within portions of a floor area with fixed seats in an assembly occupancy where these portions are not part of an **accessible route to spaces** designated for wheelchair use; or
 - i) Within a suite of residential occupancy.
- 6) **Accessible routes** are permitted to include **ramps, curb ramps**, elevators or other elevating devices (as permitted in **Section 4.1**) where a difference in elevation exists.
- 7) Where a **facility** is on a sloped site and is accessible from street level at different floors, a person with disabilities shall not be required to travel outside to gain access to another floor.
- 8) The minimum clear width of **accessible route** shall be 1100 mm – **Figure 4.1.3 (a)**, except:
 - a) At doors, it shall be 855 mm.
Note: In order to achieve 855 mm minimum clear opening width, the actual door must be 914 mm.
 - b) Where additional maneuvering **space** is required at doorways.
 - c) At U-turns around obstacles less than 1200 mm wide, it shall be 1200 mm – **Figure 4.1.3 (b)**.
 - d) Where **space** is required for two (2) wheelchairs to pass, it shall be 2000 mm – **Figure 4.1.3 (a)**.
 - e) Where a **space** is required to allow one person using a wheelchair and one ambulatory person to pass, it shall be 1700 mm – **Figure 4.1.3 (a)**.
 - f) For public exterior routes, it shall be 1500 mm.
- 9) **Accessible routes** shall:
 - a) Have a **running slope** not steeper than 1:20; and
 - b) Have a **cross slope** not steeper than 1:50.

-
- 10) Every **accessible route** less than 1830 mm wide shall be provided with an unobstructed passing space of not less than 1830 mm in width and 1830 mm in length, located not more than 30 meters apart.
 - 11) Where aisles that are 1100 mm wide are extensive in length or terminate in a dead end, a turning **space** of 1930 mm x 1930 mm minimum at 30 m interval shall be provided.
 - 12) Where there is a change in direction along an **accessible route** and the intended destination of the route is not evident, directional **signage** shall be provided.
 - 13) All portions of an **accessible route** shall be equipped to provide a minimum level of illumination of 50 lux.
 - 14) Where the edges of **accessible routes** intersect with a vehicular route, they shall be separated from it by:
 - a) A curb with a **curb ramp**.
 - b) A railing or barrier; and
 - c) A **tactile walking indicator surfaces** surface in compliance with **Section 5.7 Tactile Walking Indicator Surfaces**.
 - 15) Except at stairs and at elevated platforms such as performance areas or loading docks, where the edge(s) of an **accessible route**, path or corridor is not level with the adjacent surface, the edge(s) shall be protected:
 - a) By a **colour contrasting** curb of at least 100 mm high where the change in level is between 200 mm and 600 mm; and
 - b) By a **guard** where the change in level is greater than 600 mm – **Figure 4.1.3 (c)**.
 - 16) Wall surfaces in corridors shall be non-abrasive below 2000 mm.
 - 17) Designated areas for snow piling to be provided at exterior **accessible routes**, located away from pedestrian routes.

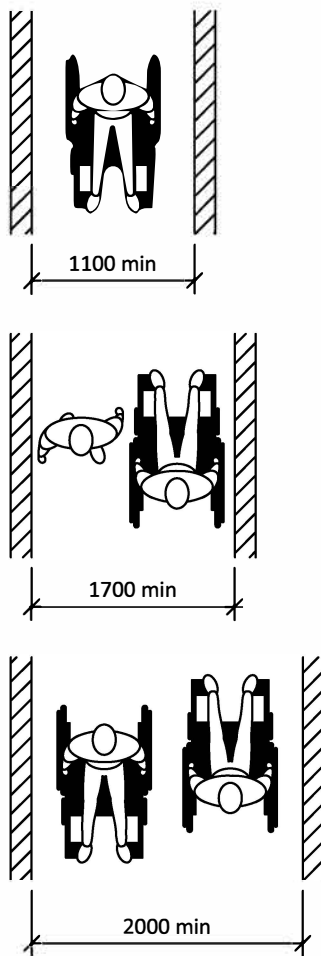

Figure 4.1.3 (a) - Access Widths

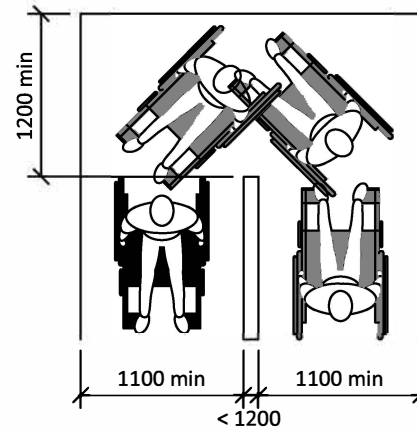
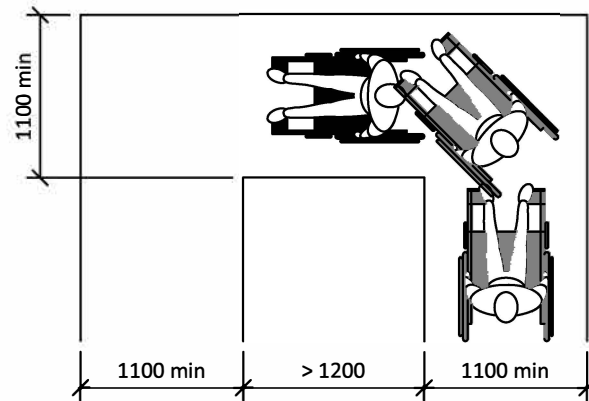

Figure 4.1.3 (b) - Turn Around an Obstacle

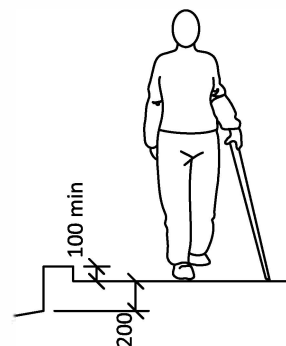

Figure 4.1.3 (c) - Edge Protection

4.1.4 Ground and Floor Surfaces

- 1) Ground and floor surfaces shall be stable, firm, slip-resistant and glare-free.
- 2) Floor surfaces shall not be heavily patterned.
- 3) Changes in level, except for elevators or other elevating devices, shall conform to **Table 4.1.4** and **Figure 4.1.4 (a)**.

| Vertical Rise | Edge Treatment |
|---------------|--|
| 0 to 6 mm | May be vertical |
| 6.1 to 13 mm | Bevel, max. slope 1:2 |
| Over 13 mm | Treat as sloped floor, ramp or curb ramp . |

Table 4.1.4 – Changes in Level

- 4) Carpets or carpet tile shall:
 - a) Be securely fixed,
 - b) Have a firm cushion, pad or backing, where used,
 - c) Have a level loop, textured loop, level cut pile, or level cut/uncut pile texture with a maximum pad and pile height of 13 mm, and
 - d) Have exposed edges fastened to floor surfaces with trim conforming to **Table 4.1.4**.
- 5) Where floor tiles are used, joints shall be no wider than 6.0 mm.
- 6) Sidewalk **accessible routes** shall be concrete.
- 7) Unless avoidance is technically not feasible, asphalt, compacted gravel, pavers and patio stones shall not be used in an **accessible route**.
- 8) Pavers shall have a joint spacing of not more than 6.0 mm, except for pavers with beveled edges where the maximum spacing between the edges of the top surface of the pavers shall be 13 mm – **Figure 4.1.4 (b)**.
- 9) Gratings located in walking surfaces shall:
 - a) Have spaces not greater than 13 mm wide in one direction, and
 - b) Be placed so that the long dimension is perpendicular to the dominant direction of travel – **Figure 4.1.4 (c)**.

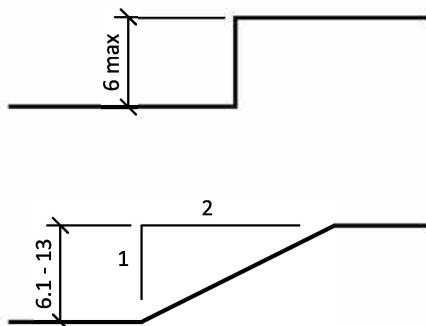

Figure 4.1.4 (a) - Changes in Level

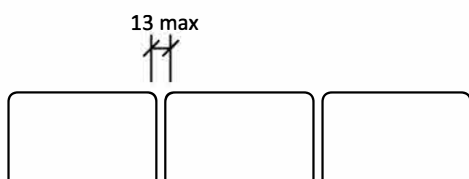

Figure 4.1.4 (b) - Joint Spacing in Pavers

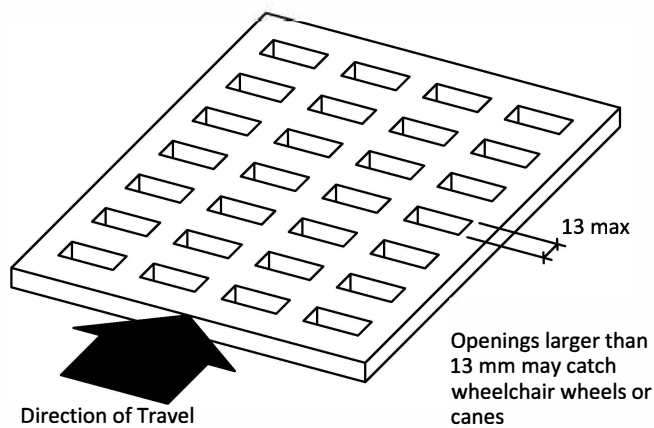

Figure 4.1.4 (c) - Grills and Gratings

4.1.5 Entrances

- 1) Provide an **accessible route** from:
 - a) The **site** boundary,
 - b) **Accessible** parking areas, and
 - c) Lay-bys and drop off zones to the main **entrance** and/or other **accessible entrances**.
- 2) An **accessible route** to an **entrance** shall be 1500 mm minimum width constructed of a firm, non-slip material.
- 3) All **entrances** used by staff or the public shall be **accessible** and comply with this section.
- 4) **Accessible** public **entrances** must be provided in a number at least equivalent to the minimum number of exits required by the National Building Code of Canada.
- 5) An **accessible** public **entrance** must be provided to each tenancy in a **facility**.
- 6) **Accessible** pedestrian routes to **entrances** should be designed so they do not cross into vehicular routes.
- 7) In situations where **accessible** pedestrian routes cross into vehicular routes, crossings with suitable **curb ramps** identified by bright yellow or white lines and/or distinct paving should be provided.
- 8) If direct access is provided for pedestrians from an enclosed parking garage to the **facility**, at least one direct **entrance** from the parking garage to the **facility** must be **accessible**.
- 9) If access is provided for pedestrians from a pedestrian tunnel or elevated walkway, one **entrance** to the **facility** from each tunnel or walkway must be **accessible**.
- 10) If the only **entrance** to a **facility** or tenancy is a **service entrance**, that **entrance** shall be **accessible**.
- 11) Where security systems are provided at public or other **entrances** required to be **accessible**, an **accessible route** shall be provided through fixed security barriers at required **accessible entrances**. Where security barriers incorporate equipment such as metal detectors, fluoroscopes, or other similar devices which cannot be made **accessible**, an **accessible route** shall be provided adjacent to such security screening devices, to facilitate an equivalent **circulation path**.
- 12) **Entrances** which are not **accessible** shall have directional **signage** complying with **Section 5.6 Signage** which indicates the nearest **accessible entrance**.
- 13) **Accessible entrances** shall be identified with **signage** complying with applicable provisions of **Section 5.6 Signage**.

4.1.6 Exterior Pedestrian Routes

- 1) Wherever possible, crosswalks shall:
 - a) Be located at right angles to the sidewalk.
 - b) Be free of obstacles (e.g., signal supports, garbage bins, mailboxes, etc.).
 - c) Have suitable **curb ramps** at each end of the crosswalk or where level differences of 13 mm or more occur – **Figure 4.1.6 (a)**.
 - d) Have a minimum width of 3000 mm - **Figure 4.1.6 (b)**.
 - e) Be clearly marked by 100 mm wide white painted lines or by using distinctive highly contrasting paving materials.
 - f) Not contain manhole covers, storm gratings or other obstacles that limit free movement and where catch basins are necessary they should be positioned wherever possible on the upstream side of the crosswalk.
 - g) Where located between intersections:
 - i) have suitable **curb ramp**.
 - ii) be located in clear view of oncoming traffic in all directions.
 - iii) clearly indicate a point for vehicles to stop at a sufficient and safe distance from the crosswalk.
 - iv) be a sufficient distance from the intersection to permit a safe crossing.
 - h) Have a **tactile walking indicator surfaces** in compliance with **Section 5.7 Tactile Walking Indicator Surfaces**.
 - i) Where pedestrian activated crosswalks are provided:
 - i) push buttons shall be clearly identifiable – **Figure 4.1.6 (c)**.
 - ii) they shall be adjacent to the crosswalk.
 - iii) they shall be mounted on a nearby post at a height of 1065 mm; and have a level and clear area of 800 x 1370 mm at the post.
- 2) Wherever possible, **curb ramps** shall:
 - a) Be provided wherever there is a level change between the pedestrian route and the road surface at all street corners and where crosswalks are provided where the pedestrian path is protected from motorists by a stop sign or signal – **Figure 4.1.6 (c)**.
 - b) Have a minimum length of 1525 mm and a width of 1525 mm. Flared sides shall typically be 1525 mm – **Figure 4.1.6 (a)**.
 - c) Be at right angles to the path of travel.
 - d) Have surfaces that are slip-resistant and have a **tactile walking indicator surfaces** in compliance with **Section 5.7 Tactile Walking Indicator Surfaces**.
 - e) Have a clear and level landing of 1065 mm to 1525 mm at the top of the ramp to allow for the maneuvering of mobility aids.
 - f) Have a **ramp slope** between 1:50 and 1:20 (2% and 5%).
- 3) Pedestrian crosswalks to include accessible pedestrian signals (APS).
 - a) Accessible pedestrian signals shall comply with the Transportation Association of Canada Guidelines for Understanding, Use and Implementation of Accessible Pedestrian Signals.

4.0 PHYSICAL ACCESSIBILITY

- b) At accessible pedestrian signal locations, where pedestrian pushbuttons are used, each pushbutton shall activate both the walk interval and the accessible pedestrian signals.
- c) APS pushbuttons to be placed on the side of adjacent poles facing the pedestrian waiting area, and parallel to the associated crosswalk.
- d) The APS sound level shall be between 30 and 90 dB.
- e) Audible walk signals shall be composed of multiple high and low frequencies, with principle frequencies between 500 and 1000 Hz.
- f) Audible walk signals shall sound during the entire walk cycle, and shall be distinct for each direction of travel.

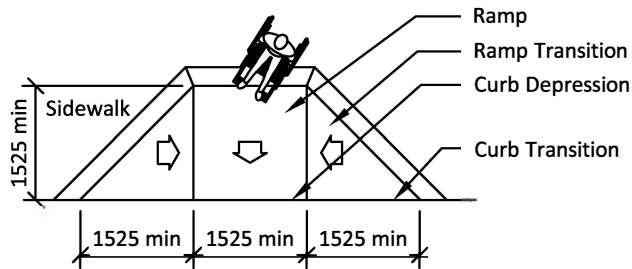

Figure 4.1.6 (a) - Curb Ramp

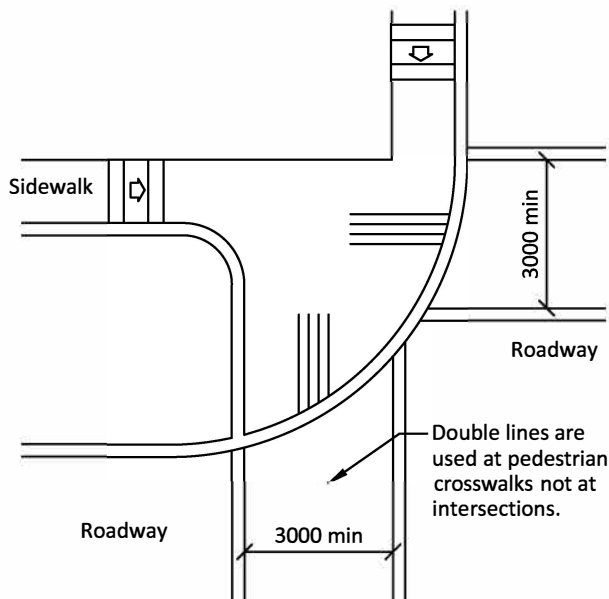

Figure 4.1.6 (b) - Curb Ramp at Crosswalks

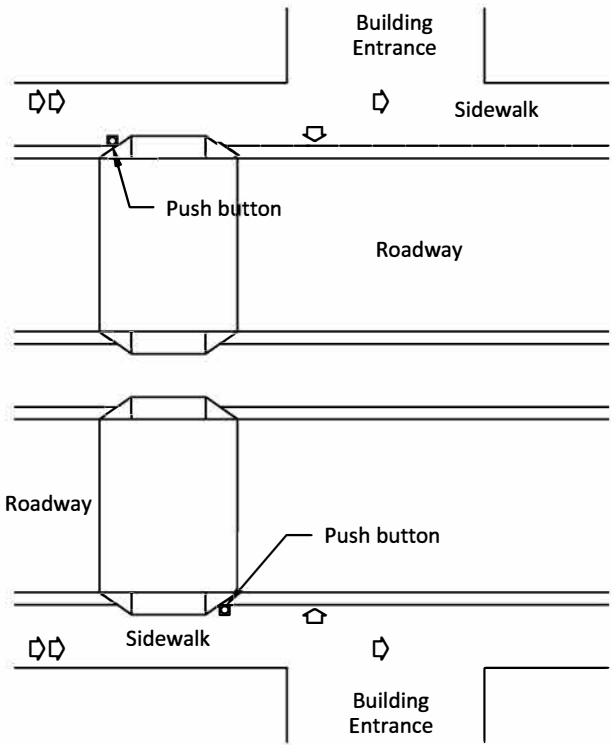

Figure 4.1.6 (c) - Signals at Crosswalk

4.1.7 Vehicular Access

- 1) An **accessible route** shall be provided from designated parking spaces, providing the shortest possible circulation route, with minimal traffic flow crossing, to an **accessible entrance** into the **facility**.
- 2) In **facilities** with multiple **accessible entrances** with adjacent parking, **accessible** parking spaces shall be dispersed and located closest to the **accessible entrances**.
- 3) Designated parking spaces shall:
 - a) Have a firm, level surface with a maximum 1.5% running slope for drainage,
 - b) Have a maximum **cross slope** of 1%,
 - c) Have a height clearance of at least 2750 mm at the parking space and along the vehicle access and **egress** routes, and
 - d) Incorporate **signage** as outlined in this section.
- 4) **Accessible** parking stalls shall:
 - a) Be at least 2700 mm wide and 5500 mm long,
 - b) Have an adjacent side **access aisle** at least 2000 mm wide clearly indicated by diagonal markings,
 - c) Have an adjacent rear **access aisle** of at least 2000 mm wide clearly indicated by diagonal markings.
 - d) Incorporate pavement markings containing the International Symbol of Access in accordance with **Figure 5.6 (a)** International Symbol of Access painted on pavement of the stall shall:
 - i) at least 1000 mm long,
 - ii) located at the centre of the stall, and
 - iii) painted white on a blue background with a white border around the symbol.

- **Figures 4.1.7 (a) and 4.1.7 (b)**
 - e) Have a designated accessible parking space sign – **Figure 4.1.7 (c)**.
 - i) sign to be at least 300 mm x 600 mm, and
 - ii) be installed at a height of 1500 mm from the ground/floor to the bottom of the sign.
- 5) Where the location of the designated parking spaces is not clear or obvious, provide directional signs along the route leading to them. Such directional **signage** shall incorporate the symbol of access and the appropriate directional arrows.
- 6) Where the location of the nearest **accessible entrance** is not obvious or is distant from the approach viewpoints, directional signs shall be placed along the route leading to the nearest **accessible entrance** to the **facility**. Such directional **signage** shall incorporate the symbol of access and the appropriate directional arrows.
- 7) Provide a suitable **curb ramp** from the **accessible** parking area to any adjacent sidewalk or pedestrian area where the difference in elevation is greater than 13 mm.

- 8) Parking meters are to be *accessible* to persons with disabilities.
- 9) The number of accessible parking spaces shall be at least one (1) or 6% of the total parking spaces, whichever is greater, in accordance with **Table 4.1.7**. At least one in every six shall be a van-sized **accessible** parking space.

| Number of Automobile Parking Spaces | Number of Accessible Parking Spaces |
|-------------------------------------|-------------------------------------|
| 50 | 3 |
| 100 | 6 |
| 150 | 9 |
| 200 | 12 |
| 250 | 15 |
| 300 | 18 |

Table 4.1.7 - Designated Parking Spaces Requirements

- 10) Passenger loading zones shall:
 - a) Be on an **accessible route**.
 - b) Be identified with **signage** complying with **Section 5.6 Signage**.
 - c) Provide an **access aisle** at least 2400 mm wide and 7000 mm long, adjacent and parallel to the vehicle pull up **space** – **Figure 4.1.7 (d)**.
 - d) Separated from the walkway by a curb containing a **curb ramp** that complies with **Section 4.1.6 Exterior Pedestrian Routes**.
 - e) Have a minimum vertical clearance of 3350 mm at the loading zone and along the vehicle access route to such areas to and from the **site entrances** – **Figure 4.1.7 (e)**.

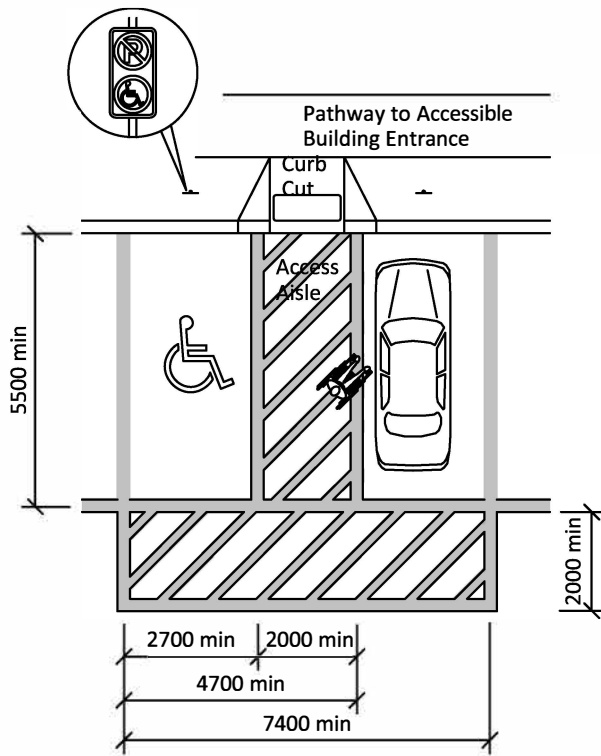

Figure 4.1.7 (a) - Side-by-Side Parking Space

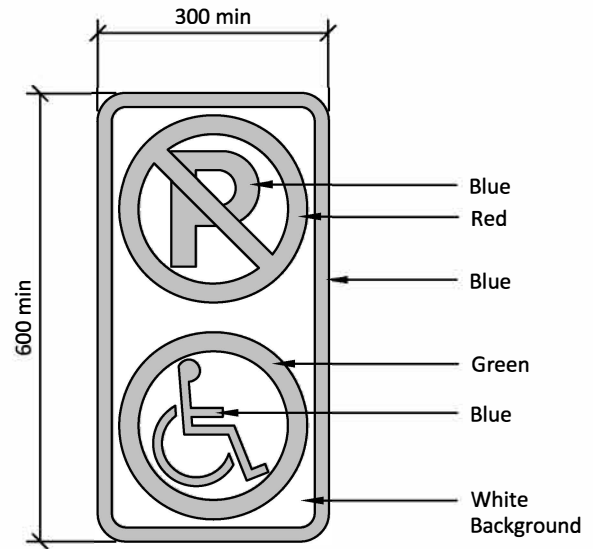

Figure 4.1.7 (c) - Designated Parking Signs

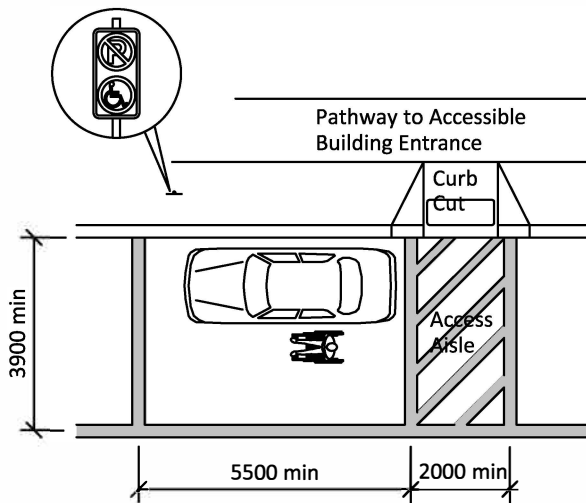

Figure 4.1.7 (b) - Parallel Parking Space

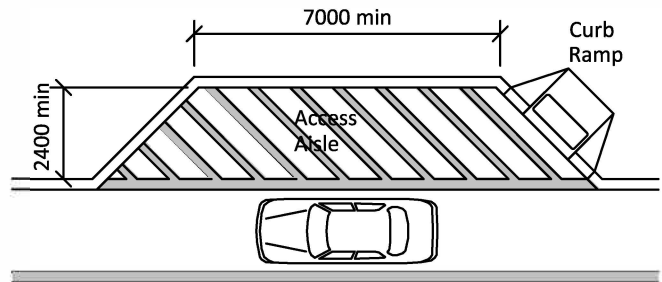

Figure 4.1.7 (d) - Passenger Loading Zone

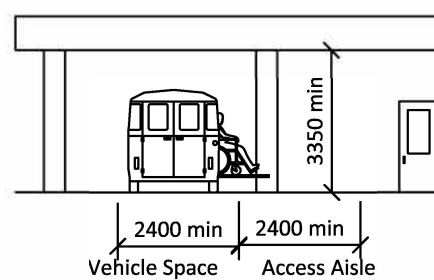

Figure 4.1.7 (e) - Clearances at Passenger Loading Zone

4.1.8 Doors

- 1) All doors used by staff or the public shall comply with this section.
- 2) Each door that is an **element** of an **accessible route** shall comply with this section.
- 3) Each door required by **Section 4.4.2 Emergency Exits, Fire Evacuation and Areas of Rescue Assistance** shall comply with this section.
- 4) Opening Widths: the clear opening width of doorways shall be as least 855 mm.

Note: In order to achieve 855 mm minimum clear opening width, the actual door must be 914 mm.

- a) Swing doors: when measured between the face of the door or the panic hardware and the face of the stop, with the door open 90° - **Figures 4.1.8 (a), 4.1.8 (b), 4.1.8 (c)**.
- b) Sliding doors: when measured between the edge of the open door and the door frame – **Figure 4.1.8 (d)**.

| Context | Floor Space Required (mm) | | |
|--|---------------------------|-------|--------------------|
| | Depth | Width | Space Beside Latch |
| Side-Hinged Door – Front Approach – Figure 4.1.8 (g) | | | |
| Pull Side | 1525 | 1700 | 625 |
| Push Side | 1370 | 1250 | 325 |
| Side-Hinged Door – Latch Side Approach – Figure 4.1.8 (f) | | | |
| Pull Side | 1370 | 1600 | 625 |
| Push Side | 1370 | 1525 | 625 |
| Side-Hinged Door – Hinge Side Approach – Figure 4.1.8 (e) | | | |
| Pull Side | 1930 | 1930 | 625 |
| Push Side | 1370 | 1830 | 625 |

| Sliding Door - Figure 4.1.8 (h) | | | |
|---------------------------------|------|------|-----|
| Front Approach | 1370 | 1100 | 325 |
| Side Approach | 1370 | 1550 | 625 |

Table 4.1.8 - Maneuvering Space at Doors

- 5) Doors shall have a level wheelchair maneuvering area on the push and pull sides of the door as described in **Table 4.1.8 – Figures 4.1.8 (e), 4.1.8 (f), 4.1.8 (g), 4.1.8 (h)**.
 - a) The width of the clear floor area required in **Table 4.1.8** is measured from the inside of the door frame.
 - b) The required clear space beside the latch is to be unobstructed for the full height of the door.
- 6) Where a door system incorporates multiple door leafs at a single location, at least one of the door leafs shall comply with this section.
 - a) Avoid the use of a centre post or mullion for double doors.
- 7) The distance between two swinging doors in series shall be at least 1370 mm plus the width of any doors swinging into the **space – Figures 4.1.8 (i) and 4.1.8 (j)**.
- 8) Thresholds shall:
 - a) Be not more than 13 mm high, and
 - b) Where over 6 mm high, be beveled at a maximum slope of 1:2.
- 9) Door hardware:
 - a) Operating devices such as lever handles, pulls, latches and locks shall:
 - i) be operable by one hand using:
 - a closed fist position, or
 - not require fine finger control, tight grasping, pinching, or twisting of the wrist to operate.
 - ii) be mounted between 900 mm and 1100 mm from the floor.
 - iii) on sliding doors, be exposed and usable from both sides when sliding doors are fully open, usable with a closed fist.
 - b) Provide:
 - i) lever handles on doors with latches – **Figure 4.1.8 (k)**.
 - ii) “U” shaped door lever handles.
 - iii) panic hardware that does not interfere with passage through a doorway.
 - iv) kick plates at least 250 mm high on the push side of doors in high traffic areas.
- 10) The maximum door opening force for pushing or pulling open a door shall be:
 - a) 38 N for exterior swinging doors.
 - b) 22 N for interior swinging doors.
 - c) 22 N for sliding or folding doors.
- 11) Door Closers:

-
- a) The sweep period of door closers shall be adjusted so that, from an open position of 90°, the door will take not less than 3 seconds to move to a semi-closed position of approximately 12°.
 - b) Door closers shall be adjusted to the least pressure possible, but never more than the opening forces noted in this section.
- 12) **Power operated Doors:**
- a) **Power operated** swinging doors shall:
 - i) take not less than 3 seconds to move from the closed to the full opened position, except when a safety sensor is installed.
 - ii) require a force of not more than 66 N to stop door movement, except when the door is equipped with a sensor that automatically stops the door if there is an obstruction in the path of movement,
 - iii) remain fully open for a minimum of 5 seconds, (the length of time is affected by the distance between the manual power assist control and the door), and
 - iv) where they open in a route of travel, have cane detectable guard rails or other barriers at right angles to the wall containing the door – **Figure 4.1.8 (I)**, and should have a clearance of 300 mm from the door.
 - b) Where power door operators are provided, they shall:
 - i) be located to allow a person using a wheelchair or scooter to stop immediately adjacent to the control,
 - ii) be adjacent to a clear floor area 800 mm x 1370 mm, that is clear of the door swing, but is no further than 1500 mm from it,
 - iii) be located no closer than 700 mm from an inside corner, for side-access,
 - iv) be located no closer than 400 mm from an inside corner, for front-approach,
 - v) if located on the hinge side of the door it controls, be located not less than 600 mm beyond the door swing, where the door opens towards the control,
 - vi) be operable at two heights, one operator with its centre located between 900 – 1100 mm from the floor, the other operator located between 150 mm and 300 mm from the floor (A single control bar that can be activated from either height is acceptable),
 - vii) incorporate controls that are clearly visible and a minimum 150 mm diameter or rectangular of at least 25mm x 75 mm,
 - viii) incorporate the International Symbol of Access in accordance with **Figure 5.6 (a)**,
 - ix) where pressure-sensitive mats, overhead beams or proximity scanners are used to detect traffic, the layout of mat, beam or scanner coverage shall ensure that wheelchair users are detected,
 - x) be operable by touching or approaching in close proximity any part of the surface with a fist, arm or foot.
 - c) At least one **power operated door** should be provided at the main **entrances** to buildings, regardless of the size of the building.

- d) **Power operated doors** to be provided for high traffic areas, e.g. individual and public washrooms.
- 13) Where doors are not equipped with a closing device, the edge of the door shall be color contrasted to the face of the door – **Figure 4.1.8 (m)**.
- 14) Doors and door frames shall incorporate pronounced **colour contrast**, to differentiate them from the surrounding environment, Door handles and other operating mechanisms shall incorporate pronounced **colour contrast**, to differentiate them from the door itself.
- 15) Mats:
 - a) Permanent mat and metal gratings at **entrances** and in vestibules shall be sunk level with the floor, so as not to create a tripping hazard.
 - b) Occasional mat (e.g. runners used in inclement weather) should be level with the floor surface and/or have a gentle beveled edge, so as not to create a tripping hazard.
- 16) Where a door incorporates glazing or is fully glazed, it shall comply with **Section 5.8 Windows, Glazing Screens and Sidelights**.

4.0 PHYSICAL ACCESSIBILITY

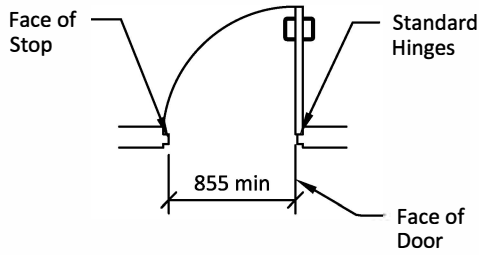

Figure 4.1.8 (a) - Minimum Clear Width at Doors - Standard Hinges

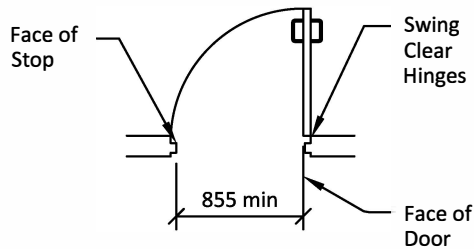

Figure 4.1.8 (b) - Minimum Clear Width at Doors - Swing Clear Hinges

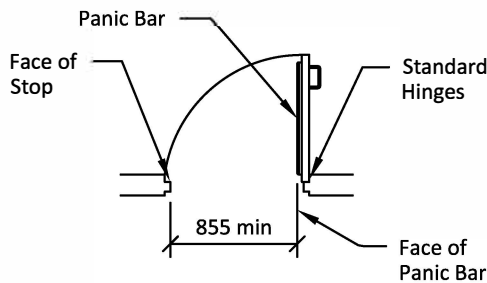

Figure 4.1.8 (c) - Minimum Clear Width at Doors - Panic Bars

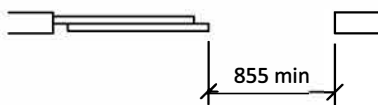

Figure 4.1.8 (d) - Minimum Clear Width at Doors - Sliding Doors

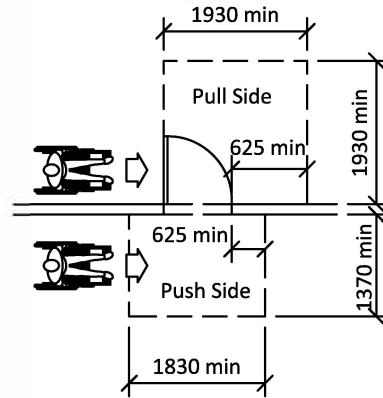

Figure 4.1.8 (e) - Hinge Side Approach at Hinged Doors

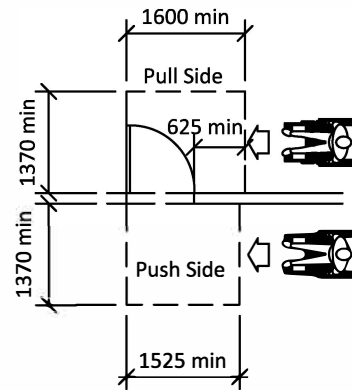

Figure 4.1.8 (f) - Latch Side Approach at Hinged Doors

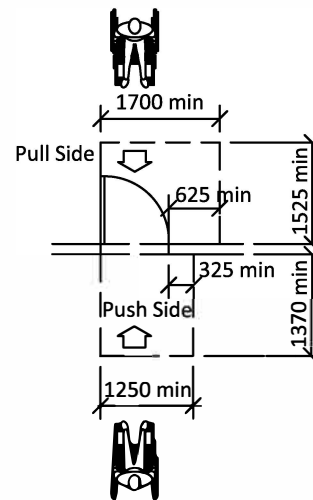

Figure 4.1.8 (g) - Front Approach at Hinged Doors

4.0 PHYSICAL ACCESSIBILITY

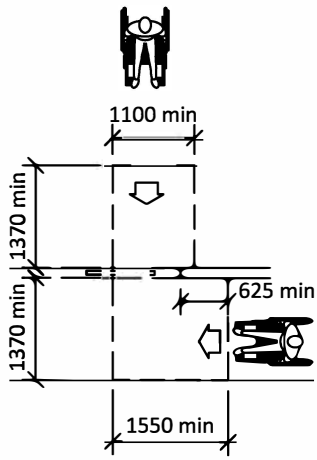

Figure 4.1.8 (h) - Front and Side Approach at Sliding Doors

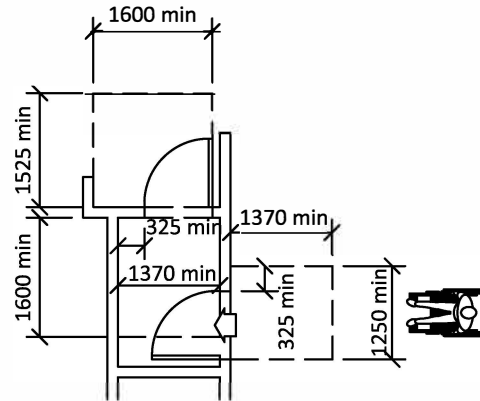

Figure 4.1.8 (j) - Maneuvering Space at Doors in Series

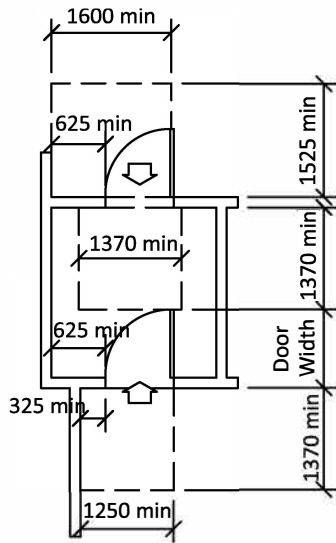

Figure 4.1.8 (i) - Maneuvering Space at Doors in Series

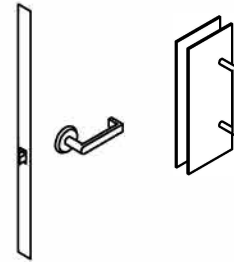

Figure 4.1.8 (k) - Examples of Accessible Hardware

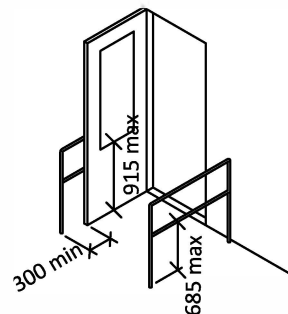

Figure 4.1.8 (l) - Detectable Safety Guards

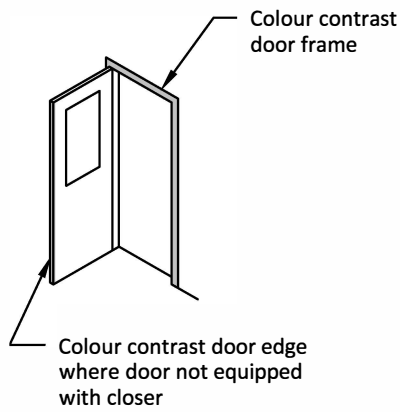

Figure 4.1.8 (m) - Colour Contrast at Doors

4.1.9 Gates, Turnstiles and Openings

- 1) Where gates or openings are provided through fences or screens to public use areas, such openings shall be **accessible**.
- 2) A minimum of 950 mm wide opening, to permit free passage of a person in a wheelchair or scooter should be provided – **Figures 4.1.9 (a) and 4.1.9 (b)**.
- 3) Hardware should be suitable for autonomous use, and any closing device should not be spring loaded.
- 4) Where turnstiles or other ticketing control devices are utilized which are not **accessible**, a gate or opening which is **accessible** shall be provided in the same location.
- 5) The **accessible** gate or opening shall incorporate the International Symbol of Access in accordance with **Figure 5.6 (a)**.
- 6) Turnstiles shall incorporate a pronounced **colour contrast** to differentiate them from the surrounding environment.
- 7) Where gates are incorporated into a chain-link fence system, the poles at either side of the gate shall incorporate a pronounced **colour contrast** from the fence and the surrounding environment.

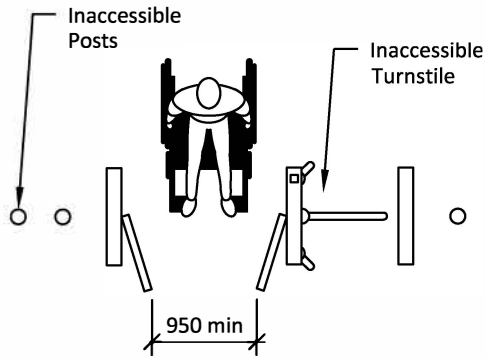

Figure 4.1.9 (a) - Access at Turnstile

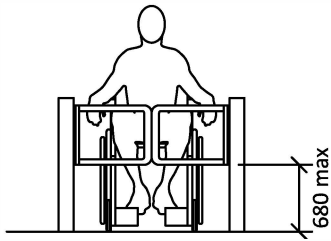

Figure 4.1.9 (b) - Access at Turnstile

4.1.10 Ramps

- 1) Any part of an **accessible route** with a slope greater than 1:20 shall be considered a **ramp** and shall comply with this section.
- 2) **Accessible ramps** shall be on an **accessible route** complying with **Section 4.1.3 Accessible Routes, Paths and Corridors**.
- 3) Where an **accessible ramp** is located in a barrier-free path of travel serving a **building entrance, signage** in compliance with **Section 5.6 Signage** shall be installed to indicate the location of the **accessible ramp** and the **accessible entrance**.
- 4) The surfaces of **ramps** and landings shall:
 - a) Have a surface that is slip resistant.
 - b) Have a 50 mm ± 10 mm **colour contrast** strip to demarcate the leading edge of the landing, as well as the beginning and end of a **ramp**.
- 5) The **ramp slope** shall be between 1:16 (6.25%) and 1:20 (5%) – **Figure 4.1.10 (a)**.
- 6)
- 7) The maximum **cross slope** of **ramp** surfaces shall be 1:50 (2%).
- 8) The minimum width of **ramps** between **handrails** shall be minimum 1000 mm – **Figure 4.1.10 (a)**.
- 9) **Ramps** shall have level landings at the top and bottom of each run and also where the **ramp** changes direction.
- 10) The maximum horizontal length between landings shall not exceed 9 m – **Figure 4.1.10 (a)**.
- 11) Landings shall:
 - a) Be at least as wide as the widest **ramp** run leading to it,
 - b) Have a minimum size not less than 2440 mm x 2440 mm if located at the top or bottom of a **ramp** or if served by a doorway – **Figure 4.1.10 (a)**.
 - i)
 - c) On an intermediate landing at the switchback of a U-shaped **ramp**, have a length not less than 1700 mm and a width not less than 2440 mm – **Figure 4.1.10 (a)**.
 - i)
 - d) On an intermediate landing at the corner of an L-shaped **ramp**, have a length and width not less than 1700 mm – **Figure 4.1.10 (a)**.
 - e) On an intermediate landing at a straight **ramp**, have a length not less than 1700 mm.
- 12) Outdoor **ramps** and their approaches shall be designed so that water will not accumulate on walking surfaces.
- 13) Edges of **ramps** and landings shall be protected with a wall or **guard** on all sides.
- 14) Where a **guard** is provided it shall:
 - a) Be not less than 1070 mm measured vertically to the top of the **guard** from the **ramp** surface.

-
- b) Be designed so that no member, attachment or opening between 140 mm and 914 mm above the **ramp** surface being protected by **guard** will facilitate climbing.
 - c) Be provided with:
 - i) a curb at least 100 mm high on any side of the **ramp** where no solid enclosure or **guard** is provided, and
 - ii) railings or other barriers that extend to within 50 mm of the finished **ramp**, or have a curb not less than 75 mm – **Figure 4.1.10 (b)**.
- 15) A **ramp** run with a rise greater than 150 mm shall have two sets of **handrails** which – **Figure 4.1.10 (c)**:
- a) Are on both sides,
 - b) Comply with **Section 4.1.12 – Handrails**,
 - c) Have a width between one set of **handrails** of 950 mm and 1100 mm,
 - d) For the first **handrail**, is located between 860 mm and 920 mm from the **ramp** surface to the top of the **handrail**,
 - e) For the second **handrail**, is located 690 mm maximum from the **ramp** surface to the top of the **handrail**,
 - f) Are continuous on the inside of a **ramp** incorporating a change in direction U-shaped or L-shaped **ramps**, and
 - g) When not continuous, extend horizontally at least 305 mm beyond the top and bottom of the **ramp**, and return to the wall, floor or post – **Figures 4.1.10 (d) and 4.1.10 (e)**.

EXCEPTION: Where a **ramp** serves as an aisleway for fixed seating, the requirements for **ramp handrails** does not apply.

- 16) **Ramps** shall incorporate **tactile walking indicator surfaces** in compliance with **Section 5.7 Tactile Walking Indicator Surfaces**.
- 17) Designated areas for snow piling to be provided at exterior **ramps**, located away from pedestrian routes.

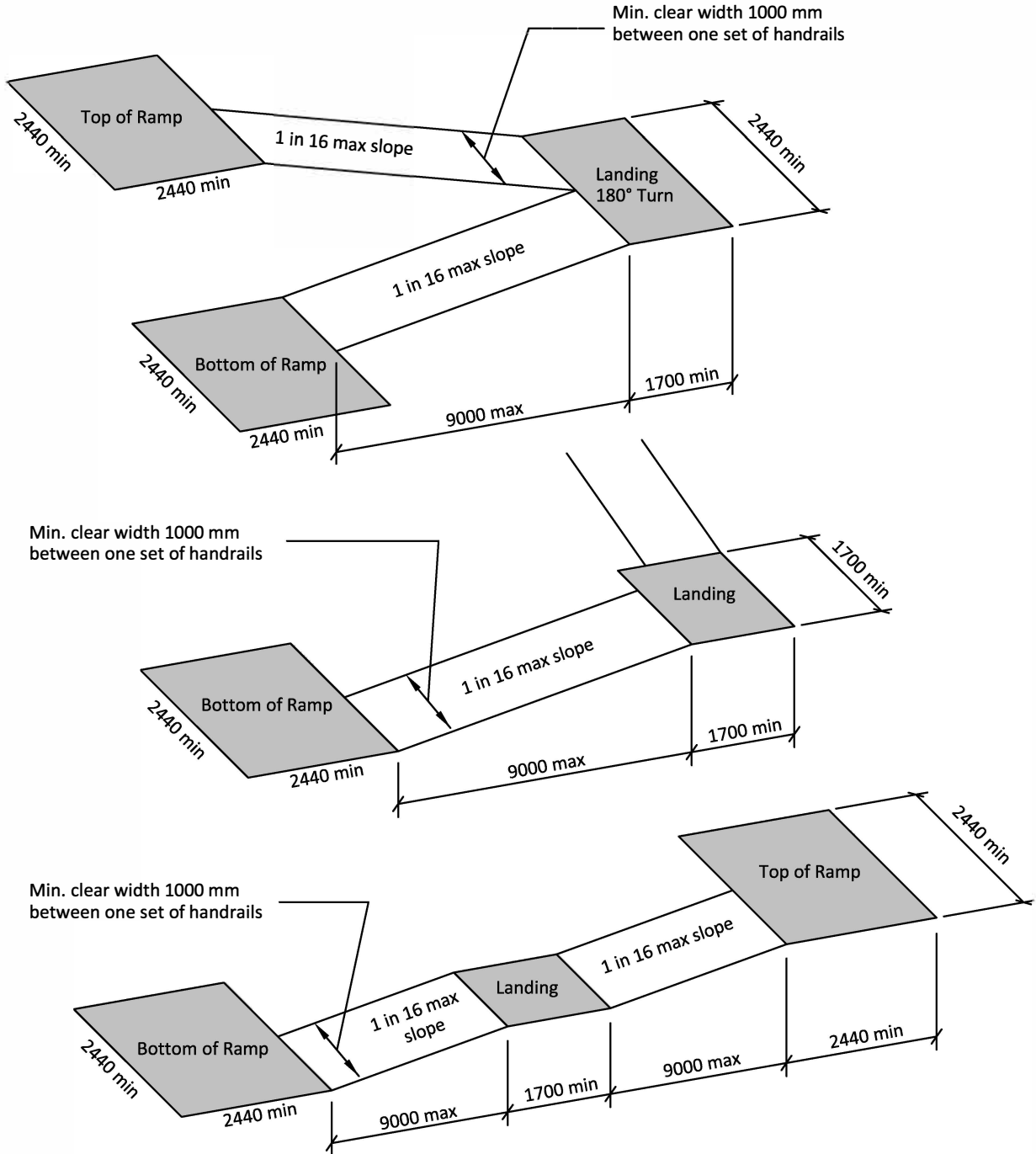

Figure 4.1.10 (a) - Minimum Ramp Landing Dimensions

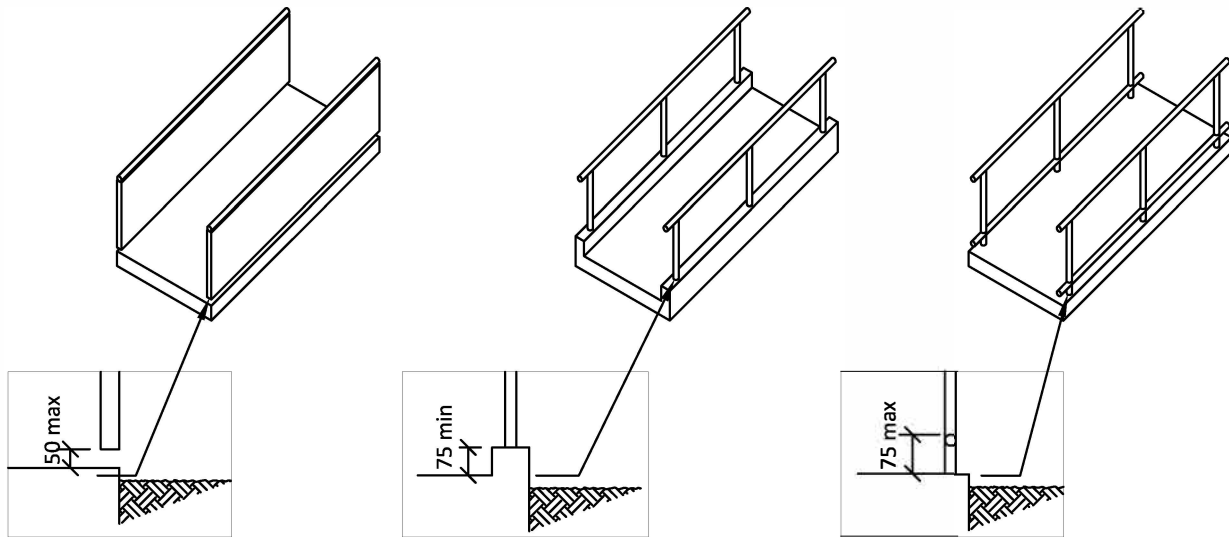

Figure 4.1.10 (b) - Edge Protection at Ramps

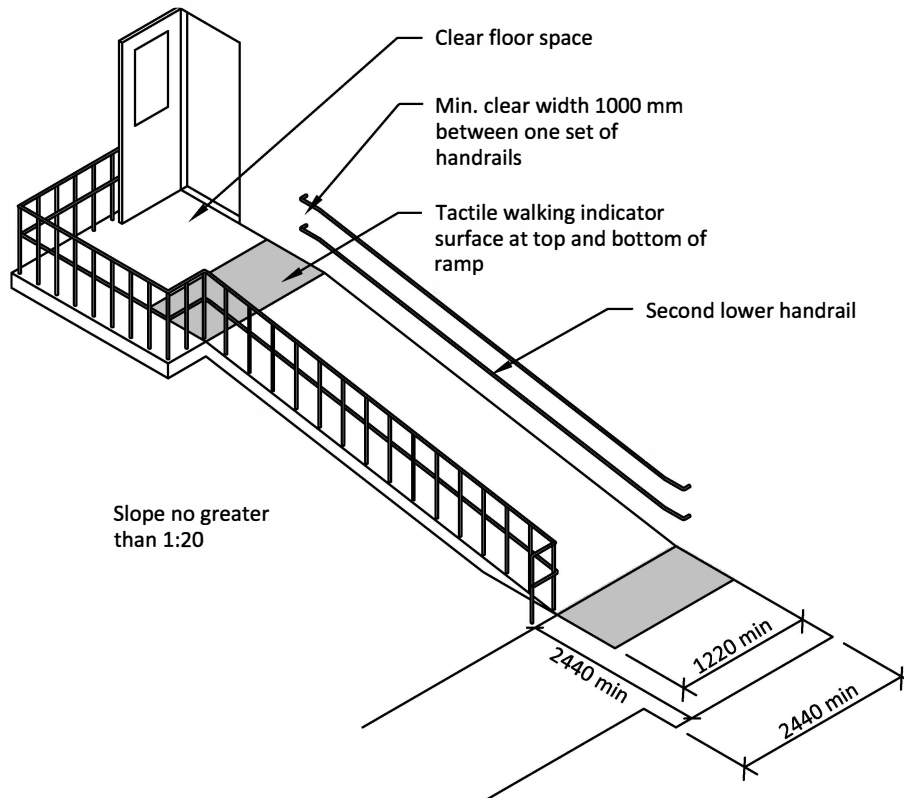

Figure 4.1.10 (c) - Ramp Criteria for Maneuvering at Doors

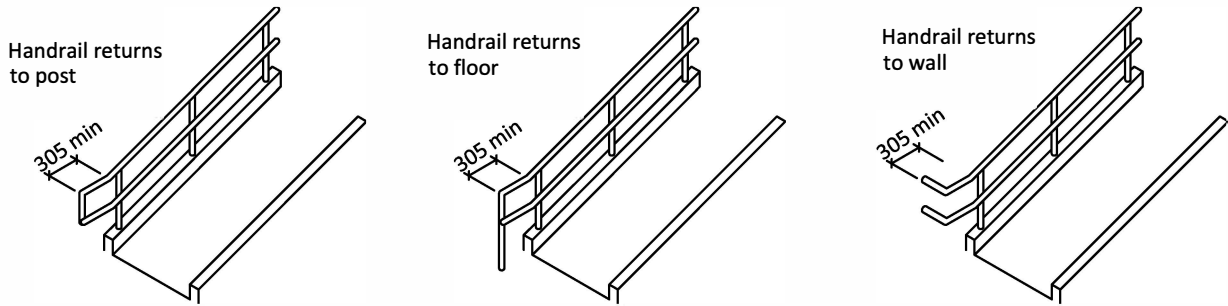

Figure 4.1.10 (d) - Horizontal Handrail Extensions

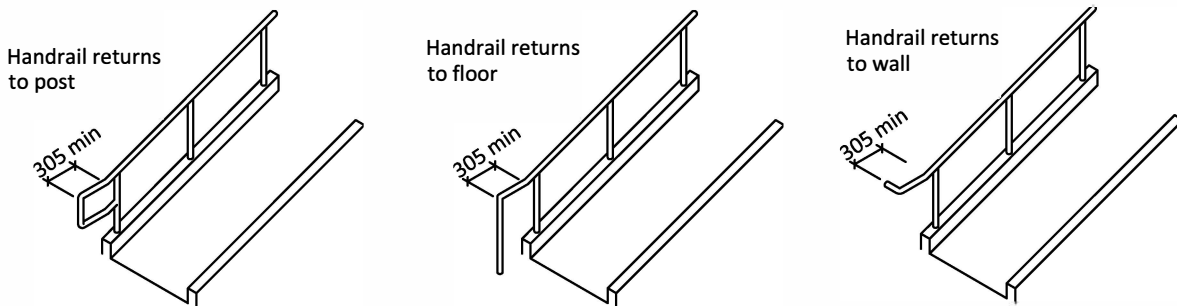

Figure 4.1.10 (e) - Horizontal Handrail Extensions

4.1.11 Stairs

- 1) All new interior and exterior stairs shall comply with this section.
 - a)
- 2) A flight of stairs shall – **Figure 4.1.11 (a)**:
 - a) Have uniform riser heights (rise) and uniform tread depths (run),
 - b) Have a rise of not more than 180 mm and not less than 125 mm high,
 - c) Have a run of not more than 355 mm and not less than 280 mm deep, measured from riser to riser,
 - d) Have no open risers,
 - e) Have treads that are slip resistant, and
 - f) Incorporate **tactile walking indicator surfaces** in compliance with **Section 5.7 Tactile Walking Indicator Surfaces**.
- 3) Nosings shall:
 - a) Project not more than 25 mm,
 - b) Have no abrupt undersides,
 - c) Have a curved or beveled leading tread edge between 6 mm and 10 mm,
 - d) Where projecting, be sloped to the riser at an angle not less than 60° to the horizontal – **Figure 4.1.11 (b)**,
 - e) Be illuminated to a level of at least 50 lux,
 - f) Be slip resistant, and
 - g) Have the horizontal and vertical surface of the stair nosing in color contrast with the remainder of the riser and tread that,
 - i) is 50 mm ± 10 mm wide,
 - ii) extends the full width of the tread, and
 - iii) is slip resistant.
- 4) **Handrails** for stairs shall:
 - a) Comply with **Section 4.1.12 Handrails**,
 - b) Be installed on both sides,
 - c) Be of uniform height, ranging from 860 mm to 920 mm above the stair nosing – **Figure 4.1.11 (c)**,
 - d) Have a continuous inside **handrail** on U-shaped or L-shaped stairs,
 - e) Where not continuous, extend at the bottom of the stairs for a distance of one tread depth beyond the first riser, then horizontally not less than 305 mm, at a height ranging between 860 mm and 920 mm above the floor – **Figure 4.1.11 (c)**,
 - f) Extend horizontally at the top of the stairs not less than 305 mm, at a height ranging between 860 mm and 920 mm above the floor – **Figure 4.1.11 (c)**, and
 - g) Return to the wall or post in a manner that will not obstruct pedestrian travel or create a hazard.
- 5) Provide dedicated areas for snow piling at exterior stairs, away from pedestrian routes.

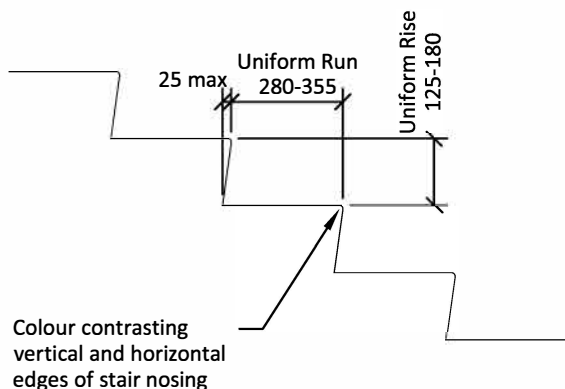

Figure 4.1.11 (a) - Stair Tread Criteria

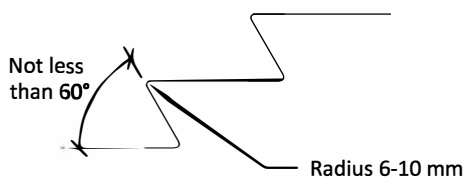

Figure 4.1.11 (b) - Raked Riser

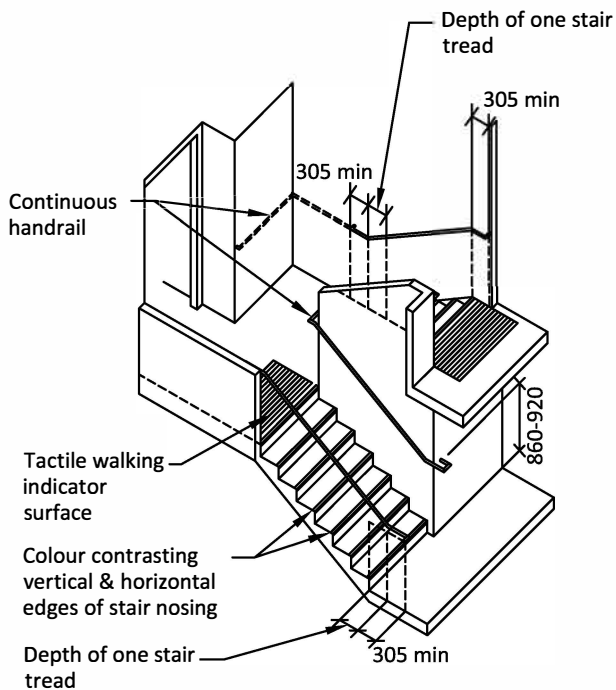

Figure 4.1.11 (c) - Stair Design Criteria

4.1.12 Handrails

- 1) **Handrails** shall:
 - a) Have a circular section 30 mm to 40 mm in diameter, or any non-circular shape with a graspable portion that has a perimeter not less than 100 mm and not more than 125 mm, and whose largest cross sectional dimension is not more than 45 mm – **Figures 4.1.12 (a) and 4.1.12 (b)**,
 - b) Be free of any sharp or abrasive **elements**,
 - c) Have continuous gripping surfaces, without interruption by newel posts, other construction **elements**, or obstructions that can break a handhold,
 - d) Have a clear space between the **handrail** and the wall of:
 - i) 40 mm to 45 mm – **Figure 4.1.12 (a)**,
 - ii) at least 60 mm where the wall has a rough surface – **Figure 4.1.12 (c)**.
 - e) Be terminated in such a manner that will not obstruct pedestrian travel or create a hazard.
- 2) A recess containing a **handrail** shall extend at least 450 mm above the top of the **handrail** – **Figure 4.1.12 (d)**.
- 3) The height of **handrails** at stairs shall be of uniform height ranging between 860 mm and 920 mm above the stair nosing – **Figure 4.1.12 (a)**.
- 4) For **ramps**, dual height **handrails** are required. The height of the set of **handrails** shall be – **Figure 4.1.12 (e)**:
 - a) For the first **handrail**, located between 860 mm and 920 mm from the **ramp** surface to the top of the **handrail**,
 - b) For the second **handrail**, located 690 mm maximum from the **ramp** surface to the top of the **handrail**.
- 5) For stairways and **ramps** greater than 2200 mm wide, one or more intermediate **handrails** continuous between landings shall be provided.
 - a) The number and position of the intermediate **handrails** shall be such that there will be not more than 1650 mm between **handrails**.
- 6) **Handrails** shall extend horizontally not less than 300 mm beyond the top and bottom of the stairway or **ramp**.
- 7) **Handrails** and their supports shall be designed and constructed to withstand the loading values obtained from the non-concurrent application of:
 - a) A concentrated load of not less than 0.9 kN applied at any point and in any direction, and
 - b) A uniform load of not less than 0.7 kN/m applied in any direction of the **handrail**.
- 8) **Handrails** shall incorporate a pronounced **colour contrast**, to differentiate them from the surrounding environment.
- 9) **Handrails** shall incorporate a contrasting **tactile** strip applied to the bottom and top edges to facilitate persons who are blind or partially sighted. Contrasting **tactile** strip shall – **Figure 4.1.12 (f)**
 - i) Be minimum 40 mm wide by 90 mm long,
 - ii) Incorporate **Braille**, raised **tactile** directional arrows and **storey** numbers.

- 10) At end of **handrail** locations, provide floor identification signs on adjacent wall for each floor level. Sign to incorporate **Braille**, and raised **tactile storey** number, and be mounted 1500 mm above the floor.

4.0 PHYSICAL ACCESSIBILITY

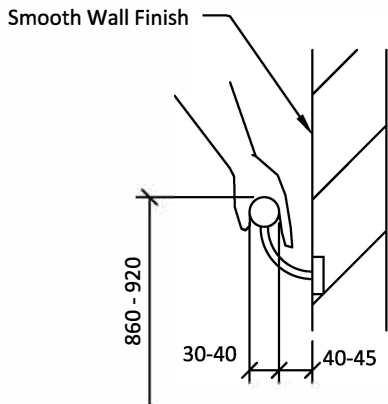

Figure 4.1.12 (a) - Handrail at Stairs

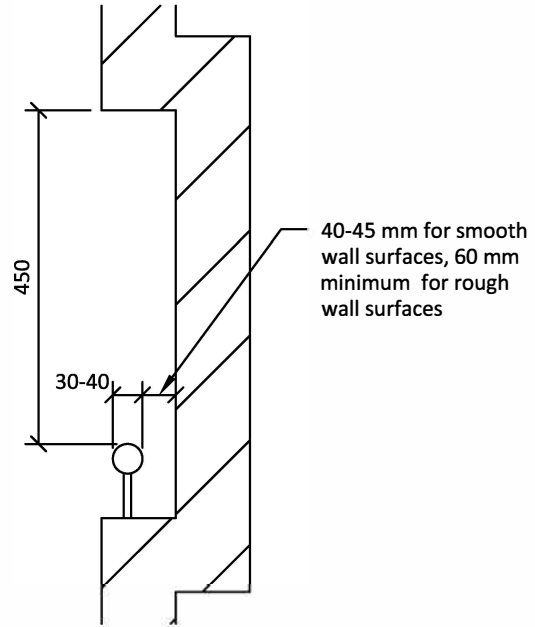

Figure 4.1.12 (d) - Handrail at Recess

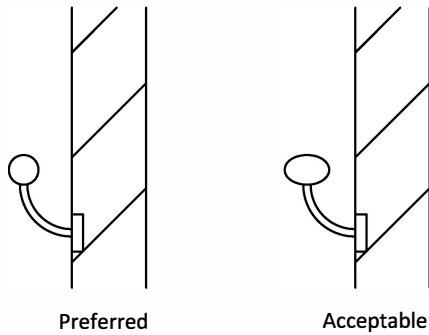

Figure 4.1.12 (b) - Preferred and Acceptable Handrail Shape

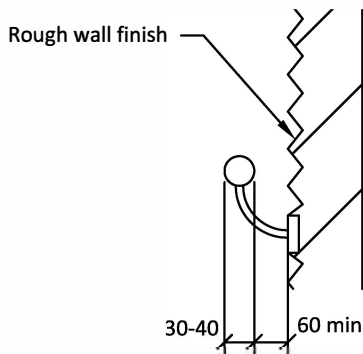

Figure 4.1.12 (c) - Handrail at Rough Wall

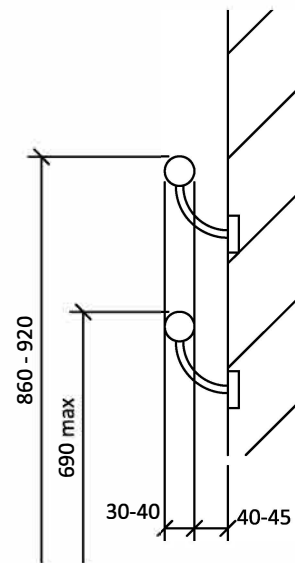

Figure 4.1.12 (e) - Handrail at Ramps

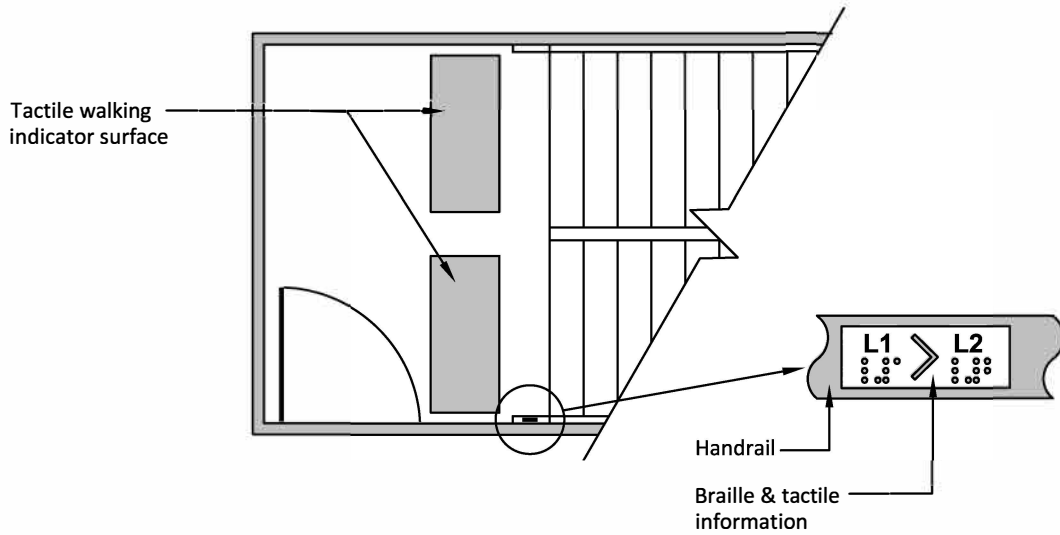

Figure 4.1.12 (f) - Tactile Wayfinding Strip at Handrails

4.1.13 Elevators

- 1) One passenger elevator complying with this section shall serve each level, including **mezzanines**, in all multi-**storey facilities**, unless exempted below. If more than one elevator is provided, each passenger elevator shall comply with this section.
- 2) Freight elevators shall not be required to meet the requirements of this section, unless the only elevators provided are used as combination passenger and freight elevators for use by the public and employees.
- 3) Elevator access is not required:
 - a) In elevator pits, elevator penthouses, mechanical rooms, piping or equipment catwalks,
 - b) When accessible ramps in compliance with **Section 4.1.10 - Ramps** are used in lieu of an elevator,
 - c) When platform lifts in compliance with **Section 4.1.14 Platform Lifts** are used in lieu of an elevator under the following conditions:
 - i) to provide an **accessible route** to a performing area in an assembly occupancy,
 - ii) to comply with wheelchair viewing position line-of-sight and dispersion requirements of **Section 4.3.8 – Elevated Areas and Platforms**,
 - iii) to provide access to incidental occupied **spaces** and rooms that are not open to the general public and which house no more than five persons including, but not limited to, equipment control rooms and projection booths, and
 - iv) to provide access to raised judges benches, clerks' stations, speakers' platforms, jury boxes and witness stands or to depressed areas such as the well of a court.
- 4) **Accessible** elevators shall be on an **accessible route**.
- 5) **Accessible** elevators shall be identified by **signage** in compliance with applicable provisions of **Section 5.6 Signage**.
- 6) Elevators shall be automatic and be provided with a two way automatic maintaining levelling device to maintain the floor level to ± 13 mm.
- 7) **Accessible** elevators shall have power operated horizontal sliding car and landing doors opened and closed by automatic means.
- 8) The clear width for elevator doors shall be minimum 950 mm. – **Figure 4.1.13 (a)**.
- 9) Doors shall be provided with a door re-opening device that will function to stop and reopen a car door and an adjacent hoist way door to at least 950 mm, in case the car door is obstructed while closing. This re-opening device shall also be capable of sensing an object or person in the path of a closing door at a nominal 125 ± 25 mm and 735 ± 25 mm above the floor without requiring contact for activation.
- 10) Elevator doors should remain fully open for at least 8 seconds. This time may be reduced by operation of the door-close button.

-
- 11) The minimum distance between the walls or between wall and door, excluding return panels, shall not be less than 1725 mm x 1525 mm. In **facilities** with high public use, such as arenas, libraries or entertainment complexes, the distance between walls or between wall and door shall be 2030 x 1525 mm – **Figure 4.1.13 (b)**.
 - 12) Car controls shall be readily **accessible** from a wheelchair upon entering an elevator.
 - a) Independent operation of the car controls shall be possible without the assistance of keys or personnel.
 - 13) Floor register buttons in elevator cabs shall – **Figure 4.1.13 (c)**:
 - a) Be a minimum 19 mm in size and may be raised, flush or recessed. The depth of flush or recessed buttons when they are being operated shall not exceed 10 mm, and
 - b) Be provided with visual and momentary audible indicators to show when each call is registered. The visual indicators shall be extinguished when each call is answered.
 - 14) All car control buttons shall be designated by Grade 1 **Braille** characters and by raised standard alphabet characters for letters, Arabic characters for numbers, and standard symbols. Markings shall be a minimum of 16 mm high and raised a minimum of 0.75 mm, placed immediately to the left of the buttons to which they apply – **Figure 4.1.13 (c)**.

Exception: Where the call buttons are mechanical, the raised markings may be on the buttons.
 - 15) Emergency car controls and door-operating buttons shall be grouped together at the bottom of the control panel. The centre line of the alarm button and the emergency stop switch shall be not less than 890 mm from the floor. The centre line of the highest floor button shall be no higher than 1200 mm from the floor. Other controls may be located where it is convenient – **Figure 4.1.13 (c)**.
 - 16) An indicator shall be provided in the car to show the position of the car in the hoist way, by illuminating the indicator corresponding to the landing at which the car is stopped or passing. Indication characters shall be on a **contrasting colour** background and a minimum of 16 mm high.
 - 17) Floors of elevator cabs shall have a firm and slip-resistant surface that permits easy movement of wheelchairs.
 - 18) **Handrails** shall be provided on all non-access walls at a height of 800 mm to 920 mm with a space of 40 mm to 45 mm between the rails and wall.
 - 19) The illumination at the car controls and landing sill shall be not less than 100 lux and shall be the same lighting level as the adjacent lobby space.
 - 20) The centre line of hall call buttons shall be 920 ± 25 mm above the floor. Buttons shall be a minimum of 19 mm in size, mounted one above the other – **Figure 4.1.13 (a)**.

- 21) Hall visual indication shall be provided to show each call that is registered and that is extinguished when the call is answered.
- 22) Hall or in-car lanterns shall be provided. The centre line of the fixture shall be a minimum of 1940 mm above the floor. An audible signal shall be provided when the elevator stops at the landing. Visual elements shall be a minimum of 60 mm in the smallest direction.
- 23) All elevator hoist way **entrances** shall have raised Arabic numerals and **Braille** floor designations provided on at least one jamb. The characters shall be a minimum of 50 mm high and raised at least 0.75 mm, and shall be placed on both sides of the door jambs, with the centreline at 1500 ± 25 mm from the floor.
- 24) As the car passes and/or stops at a floor, the floor and direction of travel shall be announced using voice-annunciation technology.
- 25) Passenger elevators shall be linked by an emergency call system to a monitored location with two way communication ability. The highest **operable portion** of any two way communication system shall be a maximum of 1200 mm from the floor of the car. It shall be identified by a raised symbol and lettering located adjacent to the device. The symbol shall be a minimum of 38 mm high and raised a minimum of 0.75 mm. Permanently attached plates are acceptable. If the system uses a handset, then the length of the cord from the panel to the handset shall be at least 735 mm. Additionally, the handset shall be equipped with a receiver that generates a magnetic field in the area of the receiver cap, and the handset shall have a volume control and shall comply with CSA Standard T515. If the system is located in a closed compartment, the compartment door and hardware shall conform to **Section 4.4.1 Controls and Operating Mechanisms**. The emergency intercommunication system shall not require voice communication. It may be in the form of a panic button.
- 26) Mirrors shall not be used below a height of 2000 mm within elevator cabs as a finish material on the wall opposite the door.
- 27) Where the area of the elevator makes it difficult for a person in a wheelchair to turn around to view the door an angled mirror shall be provided above a height of 2000 mm on the wall opposite the door, to assist persons in wheelchairs to back out.
- 28) Floor finishes within elevator cabs shall comply with **Section 5.4 Materials and Finishes**.
- 29) Elevator doors shall incorporate pronounced **colour contrast**, to differentiate them from the surrounding environment.
- 30) There shall be a pronounced **colour contrast** between the car sill and the **facility** floor.

4.0 PHYSICAL ACCESSIBILITY

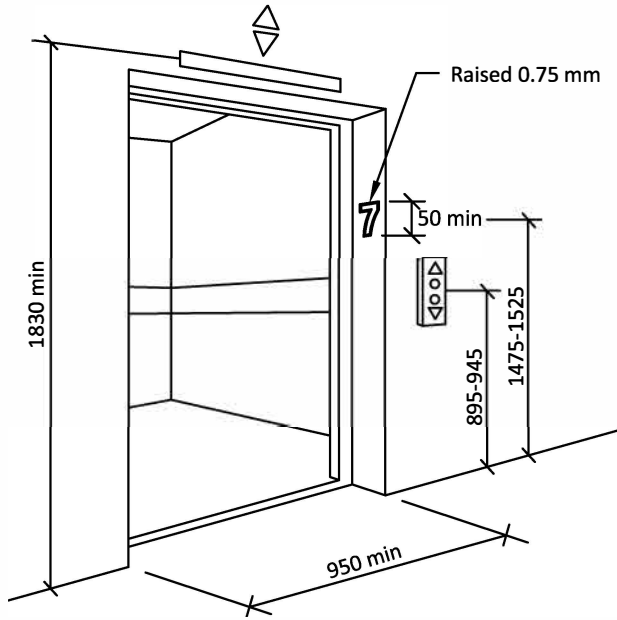

Figure 4.1.13 (a) - Elevator Entry

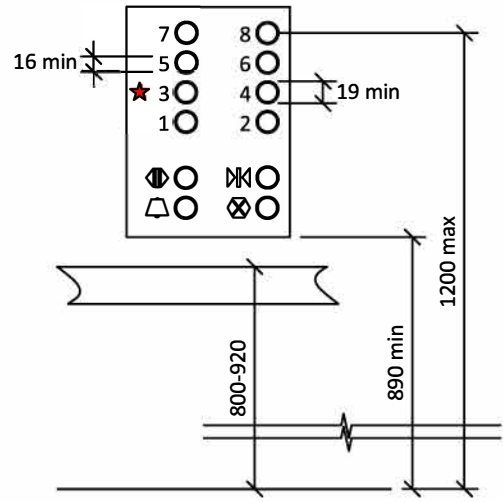
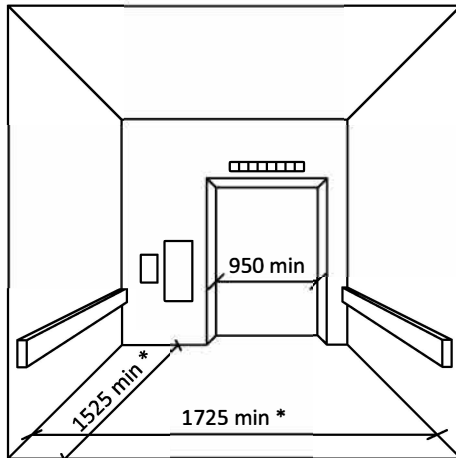

Figure 4.1.13 (c) - Control Panel



* In high-use public facilities, increase minimum dimensions to 2030 x 1525 mm.

Figure 4.1.13 (b) - Elevator Cab

4.1.14 Platform Lifts

- 1) **Accessible** platform lifts shall comply with this section.
- 2) Platform lifts cannot be located in exit stairs.
- 3) Platform lifts may only be used in lieu of an elevator or ramp where allowable under **Section 4.1.13 Elevators – Figures 4.1.14 (a) and 4.1.14 (b)**.

Exception: Where it is technically not feasible to install an elevator or other accessible means of change of level.

- 4) **Accessible** platform lifts shall:
 - a) Be on an **accessible route** complying with **Section 4.1.3 Accessible Routes, Paths and Corridors**.
 - b) Be identified with **signage** complying with applicable provisions of **Section 5.6 Signage**.
 - c) Comply with CSA standard CAN/CSA B355 (latest edition), and
 - d) Allow for unassisted entry, operation, and exit from the lift.
- 5) The platform size shall be no less than 915 x 1525 mm.
- 6) The doors to the platform lift shall comply with **Section 4.1.8 – Doors**.
- 7) Controls and operating mechanisms shall comply with **Section 4.4.1 Controls and Operating Mechanisms**.
- 8) Platform lifts shall be linked by an emergency call system to a monitored location within the **facility**, with two way communication ability. The highest operable portion of the two way communication system shall be a maximum of 1200 mm from the floor of the lift. If the system uses a handset, then the length of the cord from the panel to the hand-set shall be at least 735 mm. If the system is located in a closed compartment, the compartment door and hardware shall conform to **Section 4.4.1 Controls and Operating Mechanisms**.
- 9) Floor finishes within platform lifts shall comply with **Section 5.4 Materials and Finishes**.

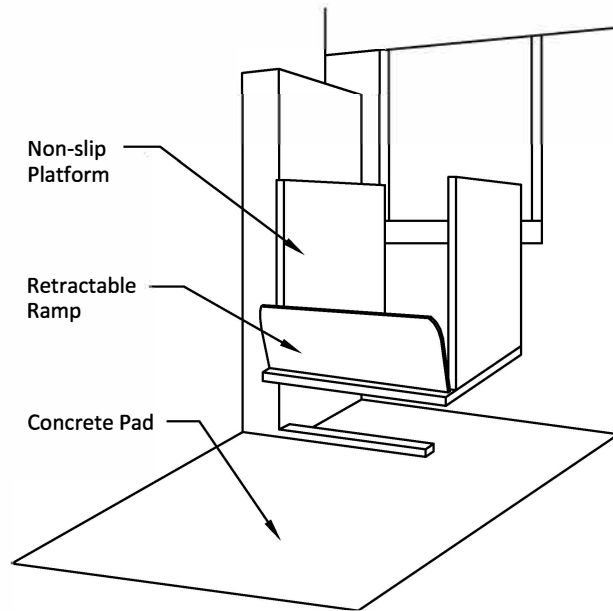
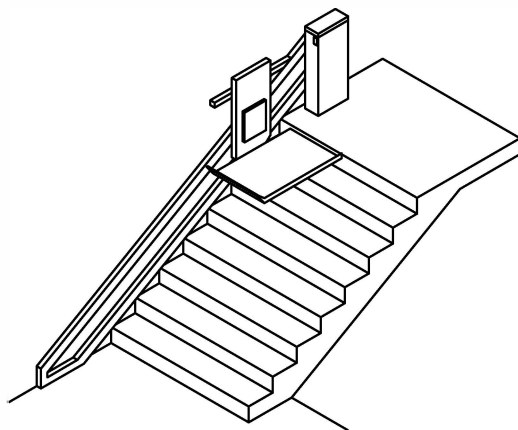

Figure 4.1.14 (a) - Vertical Platform Lift



**Figure 4.1.14 (b) - Inclined Platform
Stair-Lift**

4.2 Washroom Facilities

4.2.1 Toilet and Bath Facilities

- 1) Where toilet **facilities** are provided, each public or common use toilet **facility** shall comply with this section. Other toilet rooms provided for the use of occupants of specific **spaces** (i.e., a private toilet room for the occupant of a private office) shall be **adaptable**.
- 2) In addition to any **accessible** public or common use toilets, at least one individual washroom complying with **Section 4.2.7 Universal Washrooms** shall be provided in a public area of all public **buildings**.
- 3) In addition to any **accessible** public or common use toilets, at least one individual washroom complying with **Section 4.2.7 Universal Washrooms** shall be provided on every floor in **assembly areas** where the floor incorporates common or public use washroom containing four or more toilet and/or urinal fixtures.
- 4) **Signage** at washroom **entrances** shall comply with **Section 5.6 Signage**.
 - a) If there is no door, **signage** to be mounted on both sides of the **entrance** opening.
 - b) If individual washrooms are not visible from the common or public use washrooms, directional signage complying with **Section 4.2.7 Universal Washrooms**, shall be provided
 - c) If the washroom is not **accessible**, indicate the location and direction of the nearest **accessible** washroom.
- 5) **Accessible** toilet and bathing **facilities** shall be on an **accessible route** complying with **Section 4.1.3 Accessible Routes, Paths and Corridors**.
- 6) All doors to **accessible** toilet and bathing rooms shall comply with **Section 4.1.8 Doors**. Doors shall not swing into the clear **space** required for any fixture.
 - a) Inner vestibule doors and public washroom doors shall be equipped with power door operators.
- 7) The **accessible** fixtures and controls within toilet and bathing **facilities** shall be located on an **accessible route** which is at least 1200 mm wide and in compliance with **Section 4.1.3 Accessible Routes, Paths and Corridors**.
- 8) A clear floor **space** shall be provided:
 - a) At the **entrance** or door complying with **Section 4.1.8 Doors**, and
 - b) At the front of **accessible** toilet or bathing stalls to allow a wheelchair with a 1930 mm turning radius to make a 180° turn – **Figure 4.2.1 (a)**.
- 9) Provide **accessible** fixtures and accessories in compliance with **Section 4.2.6 Washroom Accessories**.
- 10) Wherever possible, locate barrier free stalls:
 - a) In the most direct route from the **entrance** with the least number of turns, and
 - b) Closest to the **entrance** to avoid having to move through a crowded washroom.

- 11) An infant changing area shall be provided in single occupant washrooms and multiple occupant washrooms (both male and female). In multiple occupant washrooms they shall be located outside of the **accessible** stall.
- 12) Toilet and bathing **facilities** shall incorporate even illumination throughout of at least 100 lux.

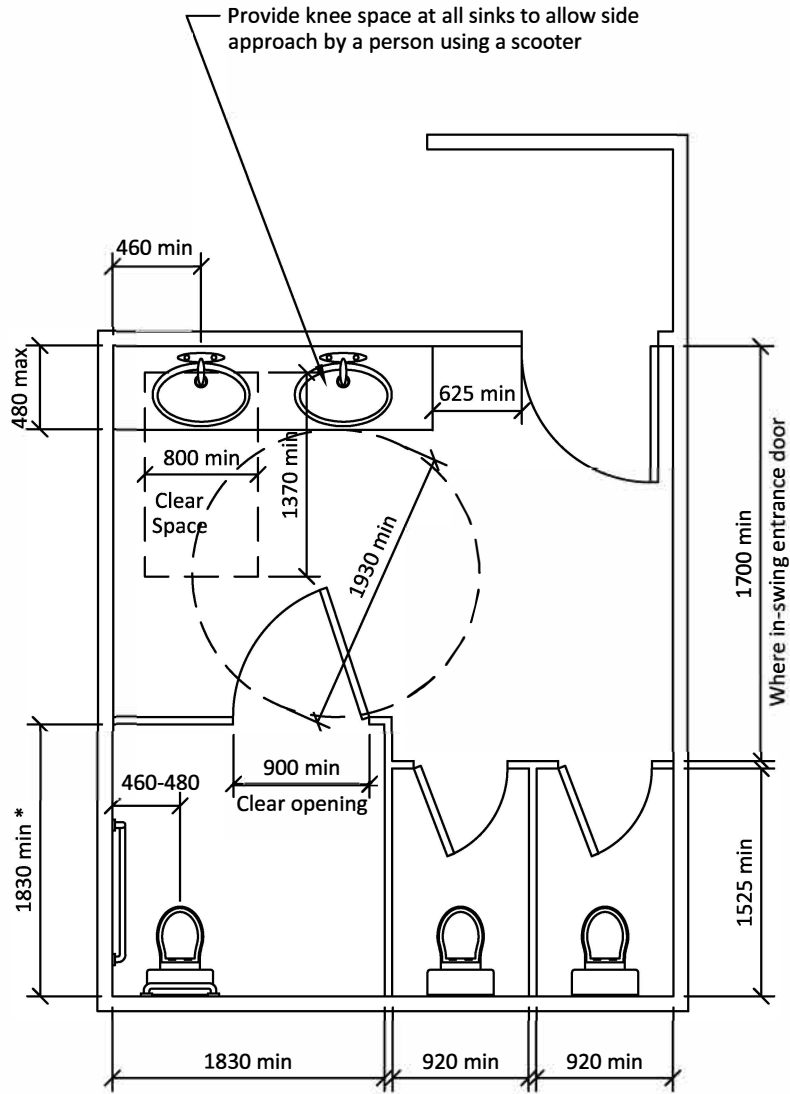

Figure 4.2.1 (a) - Washroom Dimensions

4.2.2 Toilet Stalls

- 1) **Accessible** toilet stalls shall comply with this section.
- 2) The number of **accessible** toilet stalls designated to accommodate persons with disabilities shall comply with **Table 4.2.2**.

| # of Toilet Stalls within the Washroom | Required # of Accessible Toilet Stalls |
|--|--|
| 1-10 | 1 |
| 11-20 | 2 |
| More than 20 | 3 |

Table 4.2.2 - Number of Accessible Toilet Stalls

- 3) **Accessible** toilet stalls shall have:
 - a) An internal dimension of 1830 mm x 1830 mm with out-swing doors – **Figure 4.2.2 (a)**, or an internal dimension of 1830 mm x 2290 mm with in-swing doors – **Figure 4.2.2 (b)**.
 - b) A toilet fixture in compliance with **Section 4.2.3 Toilets**.
 - c) A coat hook mounted not more than 1200 mm above the floor on a side wall,
 - d) A minimum 920 mm x 1525 mm transfer space on one side of the toilet fixture, and
 - e) Accessories positioned in such a manner so as not to obstruct movement or use of grab bars.
- 4) Where more than one **accessible** toilet stall is provided within a toilet or bathing **facility**, the stalls shall be configured with the clear transfer **space** (i.e., the open **space** beside the toilet) on opposite sides of the toilet fixtures.
- 5) Toilet stall doors shall:
 - a) Provide a clear opening of at least 900 mm with the door in the open position.
 - b) Be capable of being locked from the inside by a device that:
 - i) is operable with one hand,
 - ii) does not require fine finger control, tight grasping, pinching, or twisting of the wrist,
 - iii) requires a force of not more than 22 N to activate (e.g., sliding bolt or lever), and
 - iv) can be opened from the outside in an emergency situation by an authorized person.
 - c) Swing outward, unless additional clear **space** of at least 800 mm x 1370 mm is provided within the stall, out with the arc of the door swing.
 - d) Be aligned with the clear **space** adjacent to the toilet fixture.
 - e) Be equipped with gravity hinges so that the door closes automatically.

- f) Be provided with a “D”-type **colour contrasting** door pull, at least 140 mm long, on the inside of an out-swinging door, located so that the centre line is between 200 mm and 300 mm from the hinged side of the door, located 900 mm above the finished floor.
- g) Be provided with a “D”-type **colour contrasting** door pull at least 140 mm long, on both sides of the door, located near the latch, 900 mm above the finished floor.
- 6) Limited mobility toilet stalls shall be standard sized stalls equipped with:
 - a) Horizontal grab bars, one on each side, which complies with **Section 4.2.10 Grab Bars**.
 - b) A toilet fixture that complies with **Section 4.2.3 Toilets**.
 - c) A door that:
 - i) opens outward,
 - ii) is self-closing so when at rest the door will be ajar not more than 50 mm beyond the jamb.
 - d) A latching device that:
 - i) is operable with one hand,
 - ii) does not require fine finger control, tight grasping, pinching, or twisting of the wrist,
 - iii) requires a force of not more than 22 N to activate (e.g., sliding bolt or lever), and
 - iv) can be opened from the outside in an emergency situation by an authorized person
 - e) A sign on the door that indicates the stall is suitable for users who may require grab bar assistance – an example of which would be the image of a person with a cane.
 - f) At least one limited mobility toilet stall should be provided in each washroom.

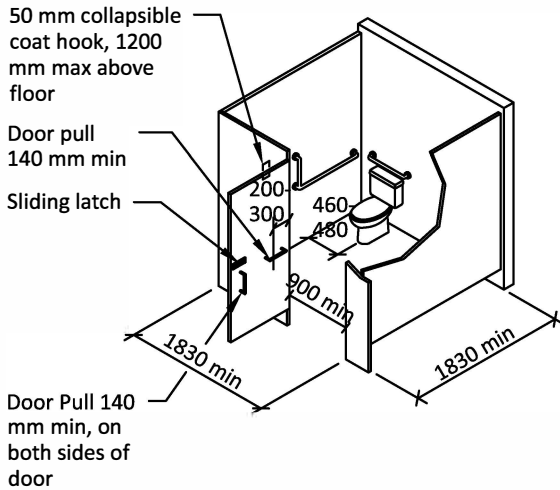

Figure 4.2.2 (a) - Accessible Toilet Stall - Out-Swing Door

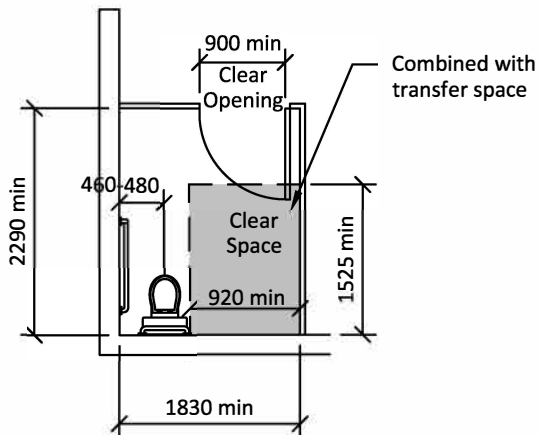

Figure 4.2.2 (b) - Accessible Toilet Stall - In-Swing Door

4.2.3 Toilets

- 1) **Accessible** toilets shall comply with this section.
- 2) Toilets fixtures shall have:
 - a) The top of the seat between 400 mm and 460 mm from the floor – **Figure 4.2.3 (a)**,
 - b) No spring-activated seat,
 - c) A back support where there is no seat lid or tank, and
 - d) Where there is a tank, a tank lid securely attached.
- 3) A toilet shall:
 - a) Be located with its centre line 460 mm to 480 mm from an adjacent wall – **Figure 4.2.2 (a)**, and
 - b) Have a clear transfer **space** at least 920 mm x 1525 mm on one side of the toilet fixture, the width measured from the edge of the toilet bowl – **Figure 4.2.2 (a)**.
- 4) Toilet flush controls shall be:
 - a) Be electronically automatically controlled, or
 - b) Hand-operated on the transfer side of the toilet, that is not more than 350 mm from the transfer space side of the toilet.
- 5) Toilets shall be equipped with grab bars that Comply with **Section 4.2.10 Grab Bars**, mounted as follows:– **Figure 4.2.3 (a)**:
 - a) One L-Shaped grab bar that is:
 - i) mounted on the side wall closest to the toilet, and
 - ii) has a horizontal component that is at least 900 mm long and a vertical components that is at least 760 mm long, such that,
 - the horizontal component is 840 mm to 920 mm above the floor, and
 - the vertical component is 450 mm in front of the toilet.
 - b) One horizontal grab bar at least 600 mm in length, mounted horizontally on the wall behind the toilet fixture, centred on the toilet bowl, mounted the same height as the grab bar on the side wall, except where the toilet has an attached water tank, in which case the grab bar shall be mounted 100 mm above the top of the tank.
- 6) A toilet paper dispenser shall:
 - a) Be wall mounted,
 - b) Be located below the grab bar, with its highest surface no closer than 60 mm from the horizontal bar.
 - c) Dispense paper 0 mm to 300 mm in front of the toilet seat and not less than 600 mm above the floor,
 - d) Be **contrasting in colour** to the wall,
 - e) Be recessed into the wall wherever possible, and
 - f) Where bulk dispensers are used recessed models are preferred. Bulk dispensers that interfere with the effective use of the grab bars are not recommended.

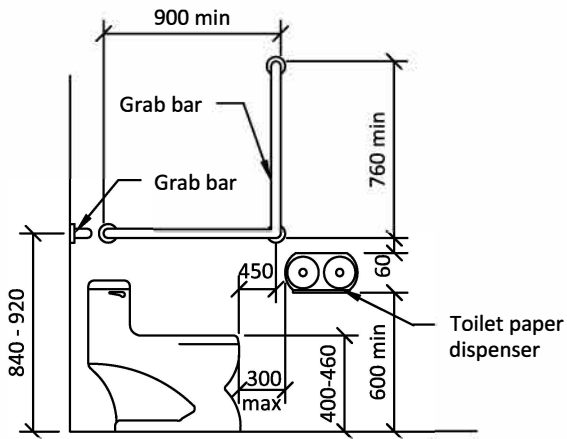

Figure 4.2.3 (a) - Grab Bar Criteria

4.2.4 Lavatories

- 1) All lavatories shall comply with this section.
- 2) Lavatories shall:
 - a) Be on an **accessible route** complying with **Section 4.1.3 Accessible Routes, Paths and Corridors**,
 - b) Be mounted so that the minimum distance between the centre line of the fixture and the side wall is 460 mm – **Figure 4.2.1 (a)**,
 - c) Have the top located between 810 mm and 860 mm above the floor – **Figure 4.2.4 (a)**,
 - d) Have a knee **space** of at least – **Figure 4.2.4 (a)**:
 - i) 800 mm wide,
 - ii) 735 mm high at the front edge,
 - iii) 685 mm high at a point 205 mm back from the front edge, and
 - iv) 230 mm high over the distance from a point 280 mm to a point 430 mm back from the front edge.
 - e) Have a minimum clear **space** 800 mm wide and 1370 mm deep, of which a maximum of 480 mm in depth may be under the lavatory,
 - f) Have hot water and drain pipes insulated if they abut the clearances noted above, or have the water temperature limited to a maximum of 43° Celsius,
 - g) Have soap and towel dispensers that are:
 - i) activated and dispensed using one hand,
 - ii) located to be **accessible** to persons who use wheelchairs or scooters (i.e., not having to reach over the lavatory to access the devices),
 - iii) located so that the dispensing height is not more than 1200 mm above the floor,
 - iv) **colour contrasted** from the surrounding environment,
 - v) in compliance with **Section 4.4.1 Controls and Operating Mechanisms**.
- 3) Faucets and other controls shall:
 - a) Be in compliance with **Section 4.4.1 Controls and Operating Mechanisms**,
 - b) Have lever-style handles (not self-closing) operable with a clenched fist, or be electronically controlled,
 - i) the lever handle in the off-position should be angled to the front.
 - ii) hot and cold faucets for lavatories, bathtubs, and showers should be oriented consistently.
 - c) Be located so that the distance from the centre line of the faucet to the edge of the basin, or where the basin is mounted in a vanity, to the front edge of the vanity is not more than 485 mm – **Figure 4.2.4 (a)**.
- 4) The front apron of a vanity shall have a minimum clearance of 760 mm wide by 735 mm high.
- 5) Shelves or other projections above lavatories shall be located so they will not present a hazard to individuals who are blind or partially sighted.

- 6) There shall be no abrasive surfaces below the vanity.
- 7) Where mirrors are provided at lavatories or vanity units, they shall comply with **Section 4.2.7 Washroom Accessories**.
- 8) Wherever possible provide sensor-activated technology to reduce the need for operating mechanisms that require strength maneuvers or reach extensions (e.g. soap, and paper dispensers, hand driers).

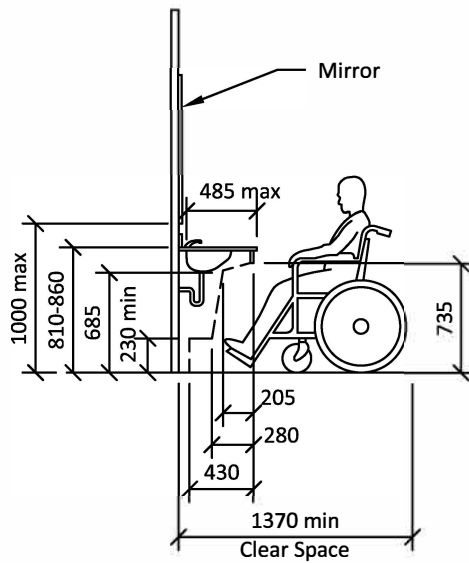

Figure 4.2.4 (a) - Lavatory Criteria

4.2.5 Urinals

- 1) Where urinals are provided in an **accessible** toilet or bathing **facility**, at least one shall comply with this section.
- 2) Urinals shall be:
 - a) Wall-mounted with the rim located between 488 mm and 512 mm from the finished floor – **Figure 4.2.5 (a)**, or
 - b) Floor-mounted, with the rim level at the finished floor.
- 3) A clear **space** of 800 mm x 1370 mm shall be provided in front of the urinal to allow for a forward approach. This clear **space** shall adjoin or overlap an **accessible route** and shall comply with **Section 4.1.1 Space and Reach Requirements – Figure 4.2.5 (b)**.
- 4) The urinal shall have grab bars installed on each side that:
 - a) Are vertically mounted,
 - b) Are not less than 610 mm long,
 - c) Have the centre line 1000 mm from the floor,
 - d) Are located not more than 380 mm from the centre line of the urinal, and
 - e) Comply with **Section 4.2.10 Grab Bars**.
- 5) Where privacy screens are provided:
 - a) There shall be at least 920 mm of clearance between them, and
 - b) They shall incorporate a pronounced **colour contrast** to differentiate them from the surrounding environment, with a vertical outer edge that **colour contrasts** with the screen and the surrounding environment.
- 6) Flush controls shall be sensor activated or hand-operated with level style control, mounted at no more than 1100 mm above the finished floor – **Figure 4.2.5 (a)**, and shall comply with **Section 4.4.1 Controls and Operating Mechanisms**.
- 7) Where a washroom contains three or more urinals, one urinal shall be provided specifically for children:
 - a) Installed with the rim no higher than 400 mm from the finished floor, or
 - b) Floor-mounted, with the rim level at the finished floor.
- 8) Provide markers for persons who are blind or partially sighted:
 - a) At floor mounted urinals, provide a highly contrasting floor, or a **contrasting coloured** edge strip, and
 - b) Each urinal shall be identified with a vertical marker that:
 - i) is centred on the urinal,
 - ii) extends to a height of at least 1300 mm above the floor, but never less than 150 mm above the upper urinal rim,
 - iii) is not less than 50 mm wide, and raised 3 mm above the surrounding wall, and
 - iv) is **colour contrasted** not less than 70% with the back wall.

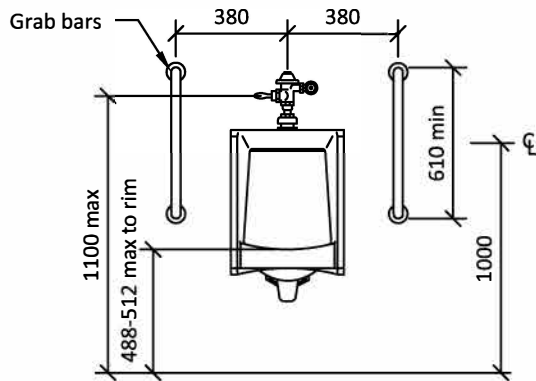

Figure 4.2.5 (a) - Urinal

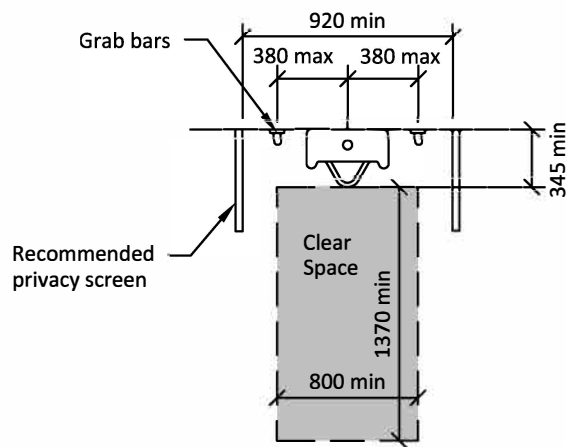

Figure 4.2.5 (b) - Urinal

4.2.6 Washroom Accessories

- 1) Where washroom accessories are provided in a toilet or bathing **facility**, they shall comply with this section.
- 2)
- 3) Automatic hands-free designs are preferred.
- 4) Each type of washroom accessory provided, except those located in toilet stalls as specified in **Section 4.2.2 Toilet Stalls** and in lavatories as specified in **Section 4.2.4 Lavatories**, shall have operable portions and controls mounted no higher than 1100 mm from the floor – **Figure 4.2.6 (a)**.
- 5) Accessories mounted over a counter shall not require a forward reach of more than 600 mm.
- 6) The operable controls and mechanisms of washroom accessories shall comply with **Section 4.4.1 Controls and Operating Mechanisms**.
- 7) Where mirrors are provided:
 - a) Be mounted with its bottom edge not more than 1000 mm from the floor, and
 - b) Not be installed where they would reflect into the path of travel.
- 8) A separate full-length mirror shall be provided elsewhere in the washroom that:
 - a) Incorporates a **clear floor space** in front, at least 800 mm wide x 1370 mm deep,
 - b) Is mounted with its lower edge 460 mm to 600 mm above the floor,
 - c) Extends to at least 1830 mm above the floor, and
 - d) Incorporates a **tactile** warning at the base of the full-length mirror to eliminate confusion with a doorway.
- 9) Baby change tables shall:
 - a) Be located with the change surface not more than 840 mm above the floor,
 - b) Incorporate an adjacent **clear floor space** not less than 800 mm x 1370 mm,
 - c) Be not less than 500 mm wide and 800 mm long,
 - d) Be capable of supporting a static load of 136 kg,
 - e) Be provided with safety straps,
 - f) Be located on an **accessible route** in compliance with **Section 4.1.3 Accessible Routes, Paths and Corridors**, and
 - g) If of the fold-down type, have no **operable portions** higher than 1100 mm.
- 10) Adult change tables shall:
 - a) Be mounted 400 mm to 500 mm above the floor,
 - b) Incorporate an adjacent **clear floor space** not less than 800 mm x 1370 mm,
 - c) Be not less than 760 mm wide and 1830 mm long,
 - d) Be capable of supporting a static load of 250 kg,
 - e) Have a smooth surface, that allows for drainage,

- f) Be located on an **accessible route** in compliance with **Section 4.1.3 Accessible Routes, Paths and Corridors**, and
- g) If of the fold-down type, have no **operable portions** higher than 1100 mm.

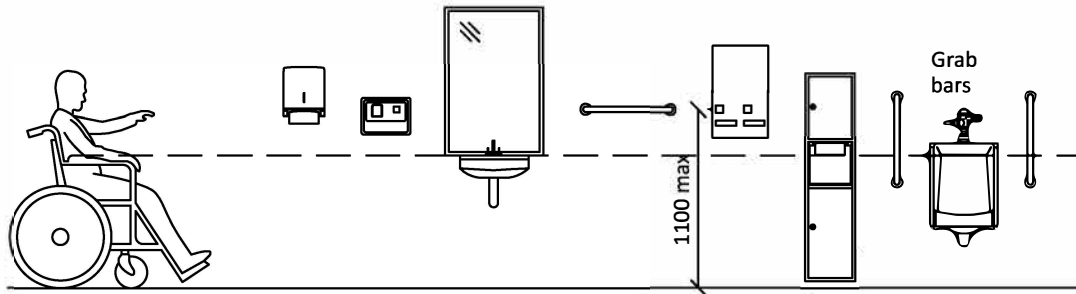

Figure 4.2.6 (a) - Washroom Accessories

4.2.7 Universal Washrooms

- 1) Universal washrooms shall comply with this section.
- 2) Universal washrooms shall be provided as required by **Section 4.2.1 Toilet and Bathing Facilities**.
- 3) Universal washrooms shall be on an **accessible route** complying with **Section 4.1.3 Accessible Routes, Paths and Corridors**.
- 4) Universal washrooms shall be identified with **signage** complying with applicable provisions of **Section 5.6 Signage**.
 - a) **Signage** should indicate:
 - i) both a male and female pictogram or gender-neutral pictogram; and/or family symbols, and
 - ii) the International Symbol of Access in accordance with **Figure 5.6 (a)**.
 - b) A courtesy sign is recommended, requesting that priority be afforded to persons in wheelchairs/scooters.
- 5) If Universal washrooms are not visible from the public use or **common use** toilets, directional **signage** complying with **Section 5.6 Signage** shall be provided.
- 6) Universal washrooms shall:
 - a) Be designed to permit a wheelchair to turn within a **clear space** that has a diameter of not less than 1930 mm – **Figures 4.2.7 (a) and 4.2.7 (b)**,
 - b) Be equipped with a door that complies with **Section 4.1.8 Doors**,
 - c) Be capable of being locked from the inside with one hand and being released from the outside in case of emergency by authorized personnel,
 - d) Have graspable latch operating and locking mechanisms located not less than 900 mm and not more than 1000 mm above the floor,
 - e) Have a minimum 140 mm long D-shaped handle mounted either horizontally or vertically on the inside, located 100 mm from the hinge edge of the door and 900 mm from the floor, where the door is out-swinging,
 - f) Be provided with a lavatory complying with **Section 4.2.4 Lavatories**,
 - g) Be equipped with a toilet fixture complying with **Section 4.2.3 Toilets**, and be located:
 - i) so that its centre line is not less than 460 mm and not more than 480 mm from an adjacent wall on one side, and
 - ii) so that its centre line is not less than 1060 mm to any wall, fixture or other obstruction on the other side.
 - h) Be equipped with grab bars complying with **Section 4.2.10 Grab Bars**,
 - i) Have fixture clearances complying with **Sections 4.2.3 Toilets and 4.2.4 Lavatories**,
 - j) Be designed to permit a wheelchair to back into the required **clear floor space** beside the toilet fixture,
 - k) Be equipped with a collapsible coat hook mounted not more than 1200 mm from the floor on a side wall and projecting not more than 50 mm from the wall,

- l) Be equipped with a mirror and washroom accessories complying with **Section 4.2.6 Washroom Accessories**, and
- m) Be equipped with a baby change table and other necessary accessories complying with **Section 4.2.6 Washroom Accessories**,
- 7) If door is out-swinging, equip with a door closer, spring hinges or gravity hinges so that the door closes automatically.
- 8) Provide a power door operator, where the door is equipped with a self-closing device, that allows a person to activate the opening of the door from either side.
- 9) Where universal washrooms are provided the following additional accessories are required:
 - a) An adult change table complying with **Section 4.2.6 Washroom Accessories** may be provided in larger public **buildings**, for persons that are too large for a traditional baby change table, and
 - b) An emergency call system that can be activated by a control located inside the washroom, which will activate audible and visual signal devices inside and outside the washroom.
 - i) Include signage posted outside the washroom with instructions on how to retrieve washroom key, open the door and render assistance in the event of an emergency.
 - ii) If the door has an electric strike, it shall be automatically released when the alarm button is pressed so that assistance can be provided.
- 10) Where more than one universal washroom is provided in a different location it is preferable to design washrooms with transfer spaces on alternating sides.

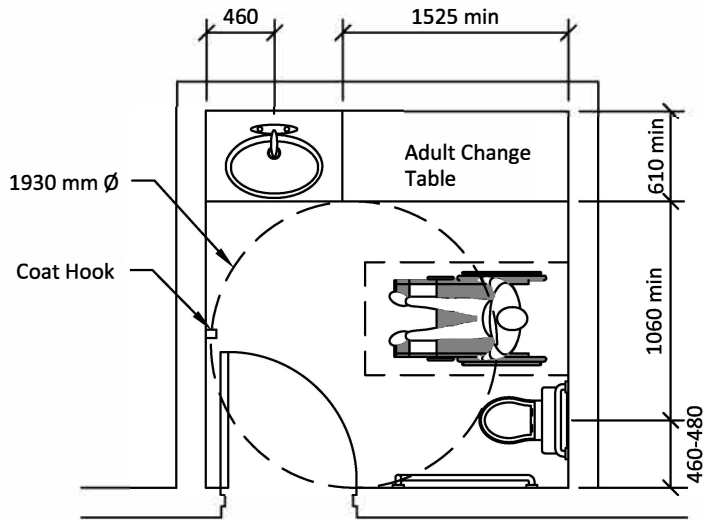

Figure 4.2.7 (a) - Individual Washroom with Fixed Adult Change Table

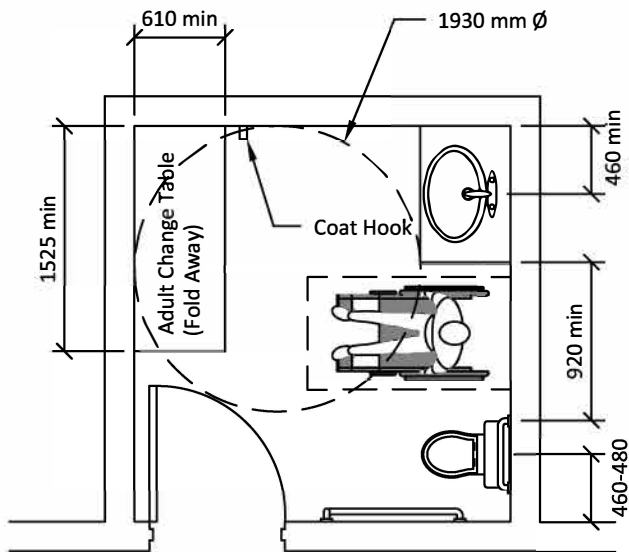

Figure 4.2.7 (b) - Individual Washroom with Fold Away Change Table

4.2.8 Bathtubs

- 1) **Accessible** bathtubs shall be on an **accessible route** complying with **Section 4.1.3 Accessible Routes, Paths and Corridors**.
- 2) **Accessible** bathtubs shall have:
 - a) A **clear floor space** at least 920 mm along the full length of the bathtub (the lavatory can encroach a maximum of 300 mm into this **space**, provided there is clear knee **space** and toe **space** under the lavatory) – **Figure 4.2.8 (a)**,
 - b) Faucet handles of lever type that are not spring-loaded, or are automatically operable,
 - c) Faucet handles that are located so as to be usable by a person seated in the bathtub,
 - d) Faucets and other controls mounted not more than 450 mm above the bathtub rim – **Figure 4.2.8 (a)**,
 - e) A shower head complying to **Section 4.2.9 Shower Stalls**,
 - f) Grab bars that comply with **Section 4.2.10 Grab Bars**, mounted as follows – **Figure 4.2.8 (a)**:
 - i) one “L” shaped grab bar:
 - with horizontal component of at least 1220 mm and vertical component of at least 920 mm,
 - mounted between 180 mm and 280 mm above the bathtub rim, and
 - mounted between 300 and 450 mm from end wall.
 - ii) two vertical grab bars at each end of the tub adjacent to the **clear floor space**, which is:
 - at least 1220 mm long,
 - with the lower end 180 mm to 280 mm above the bathtub rim, and
 - between 80 and 120 mm from the adjacent clear floor space.
 - g) Soap holder(s) which can be reached from the seated position, ideally fully recessed
- 3) Enclosures for bathtubs shall not:
 - a) Obstruct controls,
 - b) Interfere with a person transferring from a wheelchair, or
 - c) Have tracks mounted on the bathtub rim – sliding doors shall not be provided.
- 4) Slip resistant bases shall be provided.

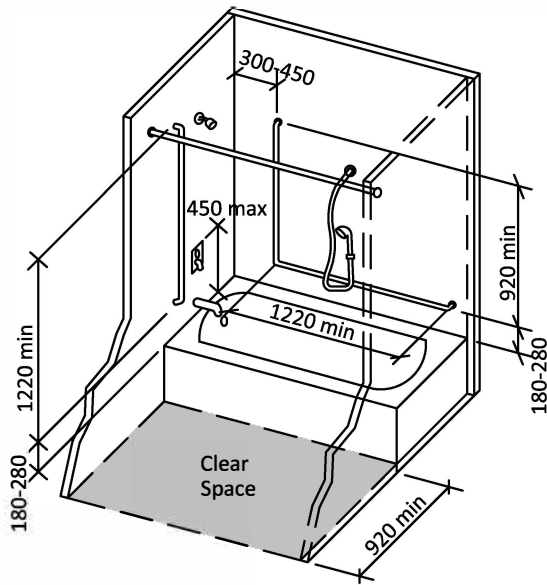

Figure 4.2.8 (a) - Bathtub

4.2.9 Shower Stalls

- 1) **Accessible** shower stalls shall be on an **accessible route** complying with **Section 4.1.3 Accessible Routes, Paths and Corridors**.
- 2) **Accessible** shower stalls shall – **Figure 4.2.9 (a)**:
 - a) Have a clear interior area of at least 920 mm x 1525 mm,
 - b) Have a **clear floor space** in front of the shower of at least 920 mm in depth and the same width as the shower, ,
 - c) Have a slip resistant floor surface, and slope minimally to provide positive drainage,
 - d) Have no threshold, or a beveled threshold not exceeding 13 mm above the finished floor,
 - e) Be equipped with a wall mounted folding seat that is not spring-loaded, or make provisions for a portable seat, that:
 - i) is 450 mm wide, extending the full depth of the stall, less a space allowed for the shower curtain,
 - ii) is mounted between 430 mm and 480 mm above the floor,
 - iii) is **colour contrasted** with the background,
 - iv) is designed to carry a minimum load of 2.70 kN, and
 - v) has a smooth, non-slip surface without rough edges.
 - f) Be equipped with a “L” shaped grab bar that shall:
 - i) comply with **Section 4.2.10 Grab Bars**,
 - ii) have a horizontal component of at least 1000 mm,
 - iii) have a vertical component of at least 760 mm located at the opposite end of the seat,
 - iv) be mounted horizontally between 750 mm and 850 mm above the floor, and
 - v) be located on the wall so that at least 300 mm of its length is reachable from one side of the seat.
 - g) Be equipped with a vertical grab bar that shall:
 - i) comply with **Section 4.2.10 Grab Bars**,
 - ii) be at least 1000 mm in length, and
 - iii) be mounted 80 mm to 120 mm from the front edge, starting between 600 mm and 650 mm from the floor.
 - h) Be equipped with a pressure equalizing or thermostatic mixing valve complying with **Section 4.4.1 Controls and Operating Mechanisms**, delivering water at a temperature no greater than 49° Celsius, located above the grab bar but no higher than 1000 mm, maximum 685 mm from the seat wall,
 - i) Have a soap holder which can be reached from the seated position, ideally fully recessed,
 - j) Be equipped with a shower head with at least 1800 mm of flexible hose that can be used both as a fixed position shower head and as a hand held shower head. The shower spray unit shall be reachable from the seated position and have an on/off control,

EXCEPTION: The use of two fixed height shower heads with the capability of adjusting the direction of water flow is permitted instead of a hand-held spray unit in facilities that may be subject to vandalism. The height of the higher shower head to be 1825 mm. The height of the lower shower head to be 1400 mm. A valve to direct water between the shower heads, in compliance with **Section 4.4.1 Controls and Operating Mechanisms**, to be located adjacent to the shower control/mixing valve.

- 3) Where the shower head is mounted on a vertical bar, the bar shall be installed so as not to obstruct the use of the grab bar. Floor drains to be level with the finished floor, located below the seat, off to one side or off to one end.
- 4) Enclosures for shower stalls shall not obstruct controls or obstruct transfer from wheelchairs onto shower seats.

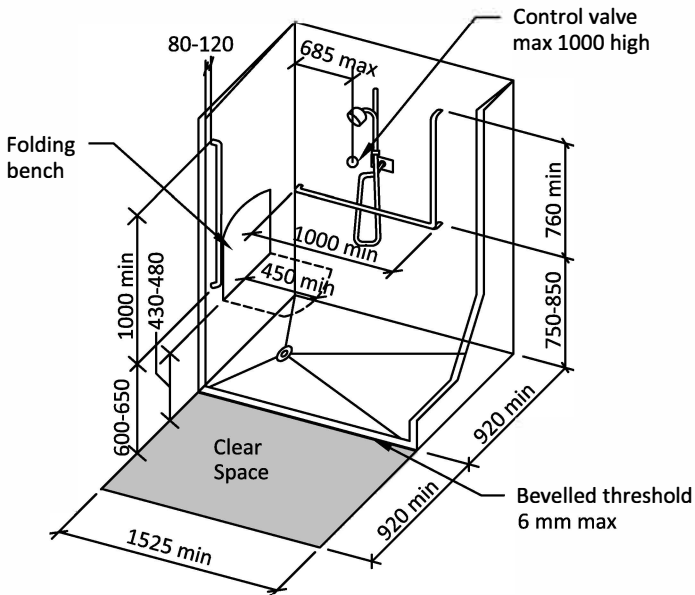

Figure 4.2.9 (a) - Shower Stall

4.2.10 Grab Bars

- 1) Grab bars shall – **Figure 4.2.10 (a)**:
 - a) Be installed to resist a load of at least 1.3 kN, applied vertically and horizontally,
 - b) Be not less than 30 mm and not more than 40 mm in diameter,
 - c) Have a clearance of 30 mm to 40 mm from the wall,
 - d) Be free of any sharp or abrasive **elements**,
 - e) Be **colour contrasted** with the surrounding environment, and
 - f) Have a slip resistant surface.
- 2) Adjacent surfaces shall be free of any sharp or abrasive **elements**.

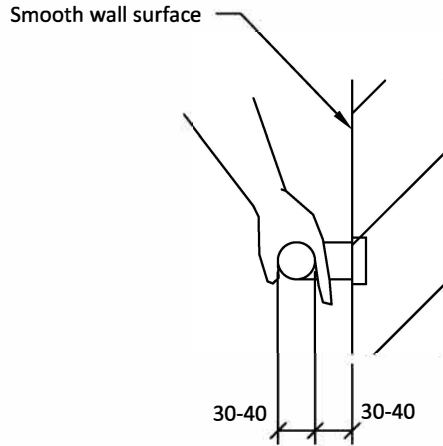

Figure 4.2.10 (a) - Grab Bar

4.3 Amenities

4.3.1 Drinking Fountains

- 1) Where drinking fountains are provided on a floor level, at least one shall be **accessible**.
- 2) Where more than one drinking fountain or water cooler is provided on a floor level, at least 50% shall be **accessible**.
- 3) Where only one drinking fountain is provided on a floor level, it shall incorporate components that are accessible to individuals who use wheelchairs in accordance with this section, as well as components that are **accessible** to persons who have difficulty stooping or bending.
- 4) **Accessible** drinking fountains shall:
 - a) Be located on an **accessible route** complying with **Section 4.1.3 Accessible Routes, Paths and Corridors**,
 - b) Have a spout located near the front of the unit between 760 mm and 900 mm above the floor or ground surface – **Figure 4.3.1 (a)**,
 - c) Have a spout that directs the water flowing at a trajectory that is parallel or nearly parallel to the front of the unit, and control the flow of water to allow for slow drinking,
 - d) Have a spout that provides a water flow at least 100 mm high, and
 - e) Be equipped with controls that are located on the front of the unit, or on both sides of the unit, easily operated from a wheelchair, using one hand, with a force of not more than 22 N, or be automatically operable.
- 5) Cantilevered drinking fountains shall:
 - a) Have a **clear floor space** of at least 800 mm x 1370 mm – **Figures 4.3.1 (a) and 4.3.1 (b)**,
 - b) Have a knee **space** between the bottom of the apron and the floor or ground of at least 800 mm wide, 200 mm deep and 685 mm high – **Figure 4.3.1 (c)**,
 - c) Have a toe **space** not less than 800 mm wide, 230 mm deep, and 230 mm high – **Figure 4.3.1 (c)**; and
 - d) Be recessed or otherwise located out of the circulation route.
- 6) Cantilevered drinking fountains that project into an **accessible route** shall be identified by a **tactile walking indicator surfaces** surface of at least 300 mm around the object, installed flush with the walkway surface, and shall be cane-detectable, recessed, or otherwise located out of the route of travel.
- 7) Freestanding or built-in fountains not having a knee **space** shall have a **clear floor space** at least 1370 mm wide x 800 mm deep in front of the unit to accommodate a parallel approach.

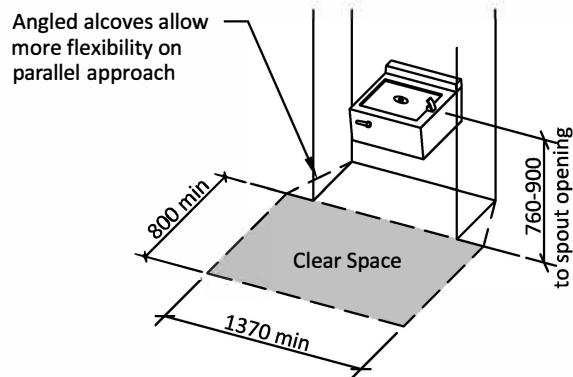

Figure 4.3.1 (a) - Parallel Approach

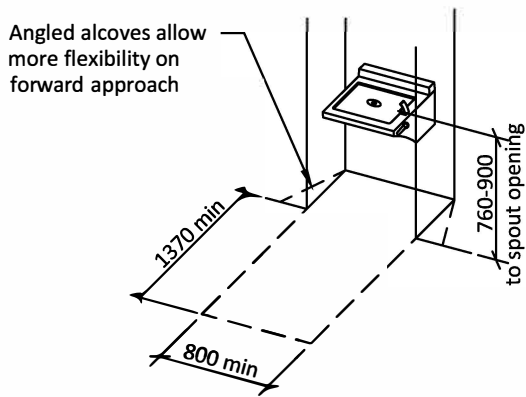

Figure 4.3.1 (b) - Forward Approach

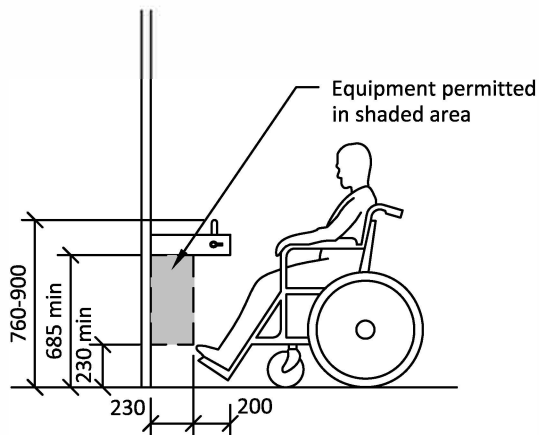

Figure 4.3.1 (c) - Clearances

4.3.2 Public Telephones

- 1) Where public telephones are provided in an area, a minimum of one telephone should be designed to be **accessible** from a wheelchair or other mobility aids.
- 2) All telephones required to be **accessible** shall be equipped with a volume control. In addition, 25%, but never less than one, of all other public telephones provided shall be equipped with a volume control and shall be dispersed among all types of public telephones, including **closed-circuit telephones**, throughout the **facility**.
- 3) **Signage** complying with **Section 5.6 Signage** shall be provided.
- 4) Where an interior public pay telephone is provided, then at least one interior public text **TTY** shall be provided in the **facility** in a public use area.
- 5) **Accessible** telephones shall be on an **accessible route** complying with **Section 4.1.3 Accessible Routes, Paths and Corridors**.
- 6) Telephones, enclosures and related equipment shall comply with **Section 4.1.2 Protruding and Overhead Objects**.
- 7) Telephones shall have push button controls where service for such equipment is available. The characters on the push buttons shall contrast with their back-ground, which should be non-glare (matte finish), and the buttons themselves should contrast with their background.
- 8) The minimum handset cord length of **accessible** telephones shall be 1000 mm.
- 9) The minimum illumination level at operating mechanisms, the directory, and shelf of **accessible** telephones shall be 200 lux.
- 10) Telephones for persons in wheel-chairs shall – **Figures 4.3.2 (a), 4.3.2 (b) and 4.3.2 (c)**:
 - a) Comply with CSA Standard T515,
 - b) Have the maximum height of operable portions, including the coin slot, 1200 mm above the floor,
 - c) Have a **clear floor space** not less than 800 mm wide x 1370 mm deep in front of the telephone, and this **space** may extend a maximum of 480 mm underneath the telephone if a clear height of 685 mm is provided for knee **space**, and
 - d) Have a flat telephone directory shelf at least 500 mm wide and 350 mm deep, with a minimum 250 mm **clear space** above the shelf, to accommodate the use of a portable text **TTY** telephone.
 - e) Be equipped with an electrical outlet, within or adjacent to the telephone enclosure, and
 - f) Be equipped with a handset capable of being placed flush on the surface of the shelf.
- 11) **Text telephones TTY's** used with a pay telephone shall be permanently affixed within, or adjacent to, the telephone enclosure. If an acoustic coupler is used, the telephone cord shall be sufficiently long to allow connection of the **TTY** and the telephone receiver.

- 12) **Accessible** telephones shall be identified by the appropriate symbol of accessibility for mobility impaired persons and/or persons who are deaf or hard of hearing.
- 13) When directional signs for telephones are installed, they shall include the appropriate access symbols.

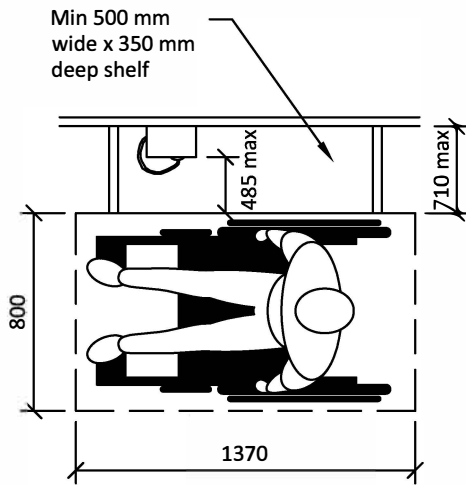

Figure 4.3.2 (a) - Parallel Approach to a Public Telephone

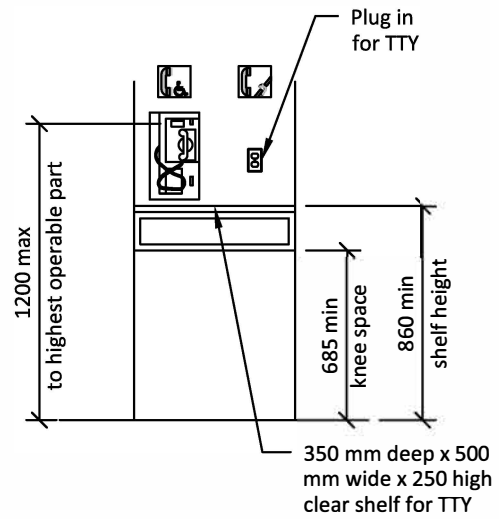

Figure 4.3.2 (c) - Accessible Telephone

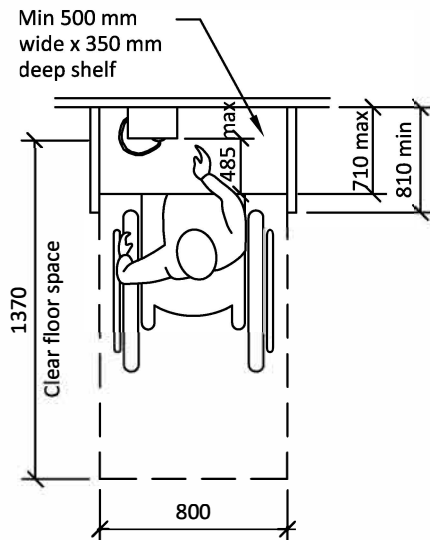

Figure 4.3.2 (b) - Forward Approach to Public Telephone

4.3.3 Information, Reception and Service Counters

- 1) Information, reception and service counters shall be located on an **accessible route** complying with **Section 4.1.3 Accessible Routes, Paths and Corridors**.
- 2) Counters for information or service shall have at least one section usable by persons in wheelchairs. The service provider shall be at the same level as those being served.
- 3) Counters for information or service shall incorporate at least one **accessible** section that – **Figure 4.3.3 (a)**. Where a counter has more than one service area, each service area shall have a barrier-free section.
 - a) Has a counter height located between 730 mm and 860 mm above the finished floor or ground,
 - b) Has a counter surface width of at least 920 mm, and
 - c) Has knee **space** on both sides of the counter, below the counter surface, of at least 685 mm high, 480 mm deep and 800 mm wide.
- 4) Wheelchair seating **spaces** at **accessible** sections of information, reception and service counters shall incorporate a **clear floor space** not less than 800 mm x 1370 mm.
- 5) Where a forward approach is used to access a wheelchair seating **space**, a clear knee **space** of at least 800 mm wide, 480 mm deep and 685 mm high shall be provided. It may overlap the **clear floor space** by a maximum of 480 mm.
- 6) Where speaking ports are provided at information, reception or service counters, at least one such position should have a speaking port no higher than 1060 mm above the finished floor or ground.
- 7) Provide counter installed drop-in deal trays at each speaker port.
- 8) If counter extension is used to accomplish adequate knee clearance, ensure it meets the requirements of **Section 4.1.3 Accessible Routes, Paths and Corridors**.
- 9) Point of sale mechanisms must be **accessible** (portable or reachable) to all users. Point of sale machines to have **braille** and audible features with a headphone jack connection.
- 10) **Signage** locating information or service counters shall comply with **Section 5.6 Signage**.
- 11) Provide **tactile direction indicator surfaces** from the entrance to information, reception or service counters complying with **Section 5.7 Tactile Walking Indicator Surfaces**.

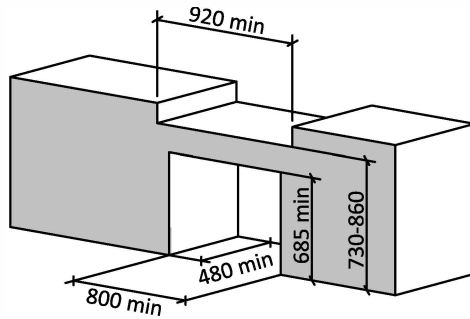

Figure 4.3.3 (a) - Service Counter

4.3.4 Offices, Work Areas and Meeting Rooms

- 1) Where offices, work areas and meeting rooms are provided for use by the general public, employees, clients or customers, they shall:
 - a) Be located on an **accessible route** complying with **Section 4.1.3 Accessible Routes, Paths and Corridors**,
 - b) Where equipped with a door, the door shall comply with **Section 4.1.8 Doors**,
 - c) Have clear **space** throughout the room allowing a person in a wheelchair to make a 180-degree turn,
 - d) Incorporate an **accessible route** through the **space** that does not require the person in a wheelchair to travel backwards to enter/leave the **space**,
 - e) Incorporate an **accessible route** that connects the primary activity **elements** within the office, work area or meeting room,
 - f) Incorporate knee clearances below work surfaces that comply with **Section 4.3.5 Tables, Counters and Work Surfaces**,
 - g) Incorporate access to storage, shelving or display units complying with **Section 4.3.7 Storage, Shelving and Display Units** for storage, shelving or display units for use by the general public, clients or customers,
 - h) Provide a clear **space** in front of the equipment that complies with **Section 4.1.1 Space and Reach Requirements**, where equipment such as photocopiers are provided for use by the general public, clients or customers, and
 - i) Be equipped with an **assistive listening system** that complies with **Section 6.5 Assistive Listening Systems**, where an **assistive listening system** is required.
- 2) Rooms intended for public use should have a sign, complying with **Section 5.6 Signage**, indicating the intended use of the room.

4.3.5 Tables, Counters and Work Surfaces

- 1)
- 2) **Accessible** tables, counters and work surfaces shall be located on an **accessible route** complying with **Section 4.1.3 Accessible Routes, Paths and Corridors**.
- 3) An **accessible route** complying with **Section 4.1.3 Accessible Routes, Paths and Corridors** shall lead to and around such counters and work surfaces.
- 4) Wheelchair seating **spaces** at **accessible** tables, counters and work surfaces shall incorporate a **clear floor space** of not less than 800 mm x 1370 mm – **Figures 4.3.5 (a) and 4.3.5 (b)**.
- 5) Where a forward approach is used to access a wheelchair seating **space**, a clear knee **space** of at least 800 mm wide, 480 mm deep and 685 mm high shall be provided. It may overlap the **clear floor space** by a maximum of 480 mm – **Figure 4.3.5 (c)**.
- 6) The top of **accessible** tables, counters and work surfaces shall be located between 730 mm to 860 mm above the finished floor or ground – **Figure 4.3.5 (c)**.
- 7) Table legs should be spaced far enough apart as to allow a wheelchair or scooter to maneuver and position under the table.
- 8) Any obstruction under the table, counter or work surface, should be clearly visible upon approach.
- 9) Cabinets shall:
 - a) Incorporate doors that are **colour contrasted**; and
 - b) Incorporate hardware that is **colour contrasted** to the doors, and is in compliance with **Section 4.4.1 Controls and Operating Mechanisms**.
- 10) Where speaker podiums are provided they shall:
 - a) Be located on an **accessible route** in compliance with **Section 4.1.3 Accessible Routes, Paths and Corridors**,
 - b) Be height adjustable for use from a seated or standing position,
 - c) Incorporate **clear floor space** of at least 800 mm x 1370 mm, configured for forward approach,
 - d) Incorporate clear knee **space** of at least 800 mm wide, 480 mm deep and 685 mm high, and
 - e) Incorporate controls and operating mechanisms complying with **Section 4.4.1 Controls and Operating Mechanisms**.
 - f) Have angle adjustment.
 - g) Have a lip at the base to hold notes.

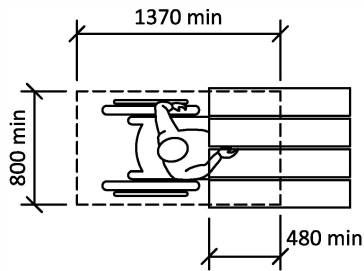

Figure 4.3.5 (a) - Forward Approach

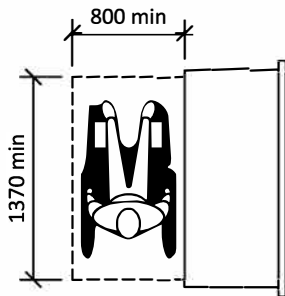

Figure 4.3.5 (b) - Parallel Approach

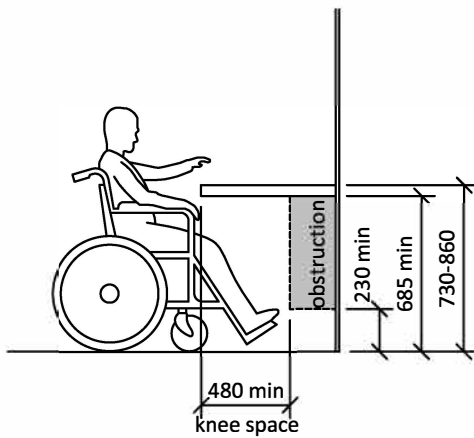

Figure 4.3.5 (c) - Clearances

4.3.6 Lockers and Storage Units

- 1) **Accessible** locker and storage units shall be located on an **accessible route** complying with **Section 4.1.3 Accessible Routes, Paths and Corridors**.
- 2) Locker and storage units shall have their bottom shelf no lower than 400 mm and their top shelf no higher than 1370 mm above the floor or ground.
- 3) Locks for **accessible** locker and storage units shall be mounted no higher than 915 mm from the floor or ground and shall comply with **Section 4.4.1 Control and Operating Mechanisms**.
- 4) Numbers or names on locker and storage units should be in clearly legible lettering, raised and of a highly **contrasting colour** or tone in compliance with the relevant parts of **Section 5.6 Signage**. Numbers and names to also be in Grade 1 **Braille**.
- 5) Aisle **spaces** in front of lockers and storage units shall be a minimum of 1370 mm deep to permit forward and lateral approach by wheelchair users.
- 6) **Accessible** locker and storage units shall be **colour contrasted** to other lockers.
- 7) The number of **accessible** locker and storage units shall be in accordance with **Table 4.3.6**.

| Total number of Lockers | Minimum number of accessible lockers |
|-------------------------|--------------------------------------|
| 1-5 | 1 |
| 6-10 | 2 |
| 11-25 | 4 |
| 36-35 | 6 |
| 36+ | 10 |

Table 4.3.6 Accessible Locker Requirements

4.3.7 Storage, Shelving and Display Units

- 1) If fixed or built-in storage **facilities**, such as cabinets, closets, shelves and drawers, are provided in **accessible spaces**, all types provided shall contain storage **space** complying with this section. This includes media display areas for brochures, drop-boxes and mail slots.
- 2) Shelves or display units allowing self-service by customers shall be located on an **accessible route** complying with **Section 4.1.3 Accessible Routes, Paths and Corridors**.
- 3) A **clear floor space** at least 800 mm x 1370 mm complying with **Section 4.1.1 Space and Reach Requirements**, which allows either forward or parallel approach by a person using a wheelchair, shall be provided at **accessible storage facilities**.
- 4) **Accessible storage spaces** shall be within at least one of the reach ranges specified in **Section 4.1.1 Space and Reach Requirements**. Clothes rods or shelves shall be a maximum of 1370 mm above the finished floor for a side approach. Where the distance from the wheelchair to the clothes rod or shelf is 255 mm – 535 mm (as in closets without accessible doors) the height of the rod or shelf shall be no more than 1200 mm – **Figure 4.3.7 (a)**.
- 5) Hardware for **accessible storage facilities** shall comply with **Section 4.4.1 Controls and Operating Mechanisms**. Touch latches and U-shaped pulls are acceptable.

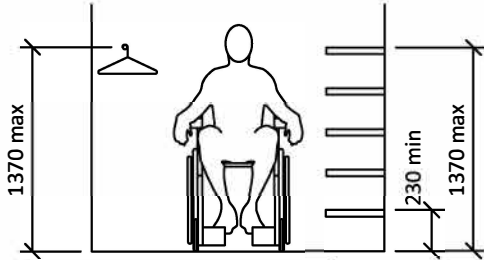

Figure 4.3.7 (a) - Reach Limits for Storage

4.3.8 Elevated Platforms

- 1) Elevated platforms provided for use by the general public, clients, customers or employees shall comply with this section.
- 2) Elevated platforms shall:
 - a) Be located on an **accessible route** that complies with **Section 4.1.3 Accessible Routes, Paths and Corridors**.
 - b) Be capable of being illuminated to at least 100 lux at floor level at the darkest point.
 - c) Be sized to safely accommodate wheelchairs and other mobility equipment in compliance with **Section 4.1.1 Space and Reach Requirements**; and
 - d) Have open platform edges defined by a **tactile walking indicator surfaces**.
- 3) The **tactile walking indicator surfaces** on elevated platforms shall:
 - a) Comply with the requirements of **Section 5.7 Tactile Walking Indicator Surfaces**.
 - b) Be consistent throughout the setting.
 - c) Be positioned parallel to the open platform edge, extending the full length of the platform, and
 - d) Be a minimum depth of 600 mm and a maximum of 650 mm, flush from the open edge of the platform, and one tread depth width from the open edge of stairs. – **Figure 4.3.8 (a)**.

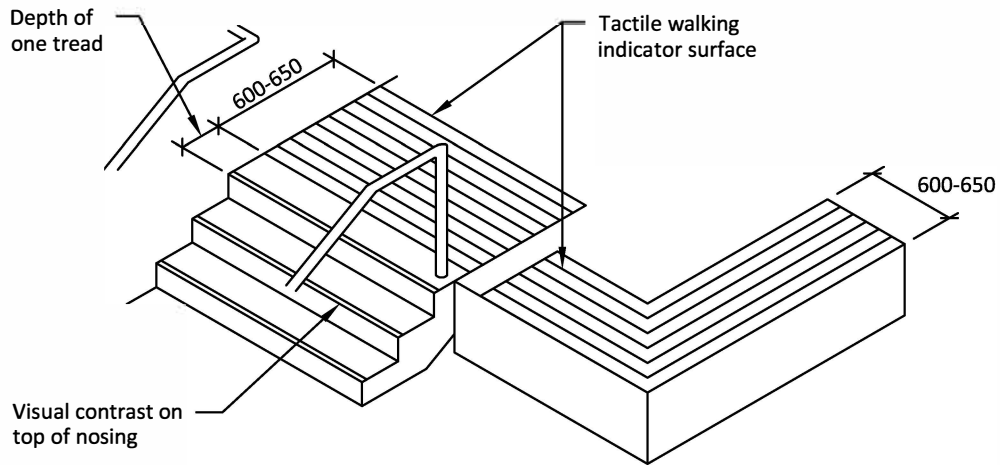

Figure 4.3.8 (a) Tactile Walking Indicator Surfaces at Elevated Platforms

4.3.9 Kitchens and Kitchenettes

- 1) Kitchens and kitchenettes intended for use by staff or the public shall comply with this section. Exception: Commercial kitchens.
- 2) At least 50% of shelf **space** in storage **facilities** shall comply with this section.
- 3) All kitchens, kitchenettes or counter areas for food preparation should be made **accessible** with: – **Figures 4.3.9 (a), 4.3.9 (b) and 4.3.9 (c)**:
 - a) A **space** of no less than 1930 mm between counters, and
 - b) A turning **space** of 1930 mm for wheelchairs and other mobility devices where kitchens have dead ends.
- 4) Storage **elements** shall:
 - a) Be located on an **accessible route** with adjacent **clear floor space** complying with **Section 4.1.1 Space and Reach Requirements**,
 - b) Comply with at least one of the reach ranges specified in **Section 4.1.1 Space and Reach Requirements**, and
 - c) Incorporate operable portions complying with **Section 4.4.1 Control and Operating Mechanisms**.
- 5) Kitchen sinks shall – **Figure 4.3.9 (d)**:
 - a) Be located on an **accessible route** with adjacent clear **space** for a forward approach,

Exceptions: A parallel approach is permitted to a kitchen sink where a cook top or conventional range is not provided and to wet bars.

- b) Where a forward approach is provided, incorporate knee **space** below at least 800 mm wide, 480 mm deep, and 685 mm high,
- c) Have the height of the rim or the counter top (whichever is higher) between 730 mm and 860 mm,
- d) Be double sinks with lower divider to allow for spillage into adjacent sink.
- e) Incorporate faucets and other controls in compliance with **Section 4.4.1 Controls and Operating Mechanisms**,
- f) Have water supply and drain pipes under the sink insulated or otherwise configured to protect against contact, and
- g) Incorporate no sharp or abrasive surfaces under the sink.
- 6) Cabinets and pantries shall have:
 - a) Upper shelves no higher than 1370 mm from the floor,
 - b) If base cabinets, a toe **space** no less than 150 mm x 230 mm, and
 - c) “D” style handles mounted at:
 - i) the bottom of the upper cabinets, and
 - ii) the top of the base cabinets.
- 7) Kitchen appliances shall:
 - a) Be located on an **accessible route** with adjacent **clear floor space** in compliance with **Section 4.1.1 Space and Reach Requirements**, and

- b) Incorporate controls and operable portions in compliance with **Section 4.4.1 Controls and Operating Mechanisms**.

Exceptions: Appliance doors and door latching devices.

- 8) Dishwashers shall incorporate **clear floor space** adjacent to the dish-washer door. The dishwasher door, in the open position, shall not obstruct the **clear floor space** for the dishwasher or sink. Dishwasher controls to incorporate tactile buttons or **braille**.
- 9) Ranges and cooktops shall **Figure 4.3.9 (e)**:
- Incorporate controls that are located to avoid reaching across the burners,
 - Incorporate raised burners. If burners are flattop, include tactile burner identification rings,
 - Incorporate tactile indicators for burner locations and temperature controls,
 - Incorporate knee **space** below at least 800 mm wide, 480 mm deep, and 685 mm high, where a front approach is provided, and
 - Insulate or otherwise configure the appliance to prevent burns, abrasions, or electrical shock.
 - A clear counter **space** of 305 mm wide shall be provided on each side of cooking ranges and cooktops for safe operation.
- 10) Ovens shall – **Figure 4.3.9 (f)**:
- Have controls located on the front panels, mounted no higher than 1200 mm,
 - Where side-hinged doors are used, be located:
 - with an adjacent work surface positioned adjacent to the latch side of the door, and
 - incorporate a pull-out shelf below the oven, and
 - Where bottom-hinged doors are used, be located with an adjacent work surface of 305 mm wide on each side of the door.
- 11) In **facilities** with children's programs, ranges, cooktops and ovens shall be equipped with a safety switch to de-activate appliance control.
- 12) Refrigerators/freezers shall – **Figure 4.3.9 (g)**:
- Be configured with the freezer shelf maximum 1100
 - mm above the floor, and
 - Incorporate **clear floor space** in front, positioned for a parallel approach immediately adjacent to the refrigerator/freezer, with the centre-line of the clear **space** offset 610 mm maximum from the front face of the refrigerator/freezer.
- 13) All kitchen **elements** shall incorporate **colour contrast** to visually differentiate the cabinets and appliances from adjacent wall and floor surfaces, the countertop from the cabinets and adjacent walls, and operable hardware on cabinets – **Figure 4.3.9 (h)**.
- 14) Microwaves shall:
- Be installed at counter height,

- b) Incorporate tactile and audible controls,
 - c) Have a **clear floor space** in front to allow easy transfer of food, and
 - d) Be larger models where possible.
- 15) Duplex receptacles shall be mounted no higher than 1065 mm when located above the counter.
- 16) Additional lighting shall be provided over the sink, cooking range and work surfaces with a minimum illumination level of 300 lux.
- 17) Flooring requirements to comply with **Section 4.1.4 Ground and Flooring Surfaces**.

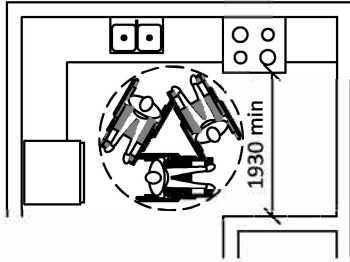

Figure 4.3.9 (a) - "Dead End" Kitchen Layout

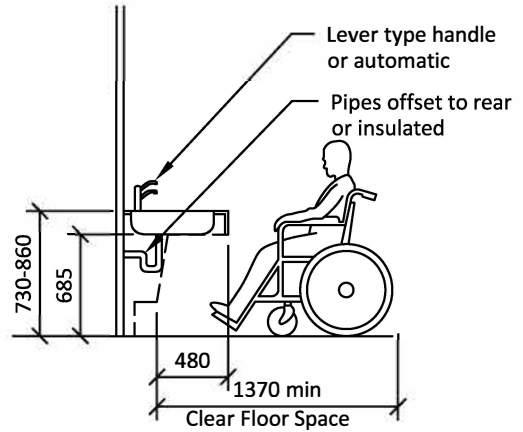

Figure 4.3.9 (d) - Kitchen Sink

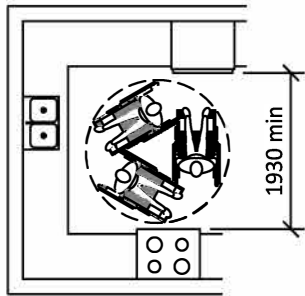

Figure 4.3.9 (b) - "Dead End" Kitchen Layout

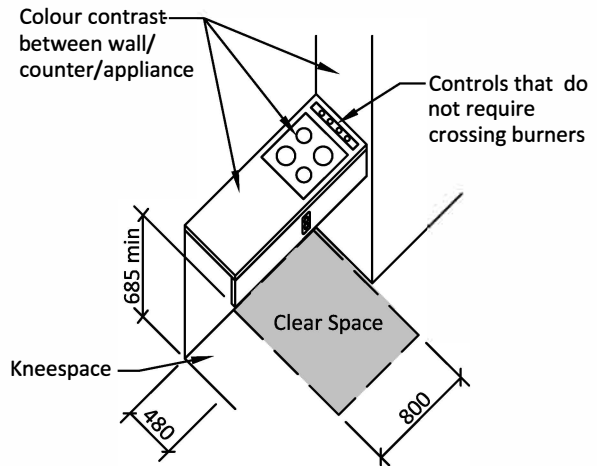

Figure 4.3.9 (e) - Cook Top

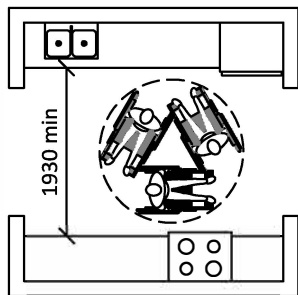

Figure 4.3.9 (c) - "Galley" Forward Reach

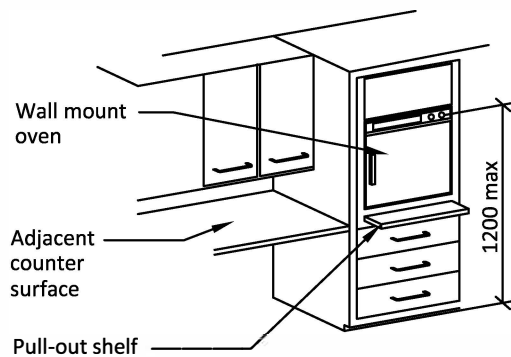

Figure 4.3.9 (f) - Wall-Mounted Oven

4.0 PHYSICAL ACCESSIBILITY

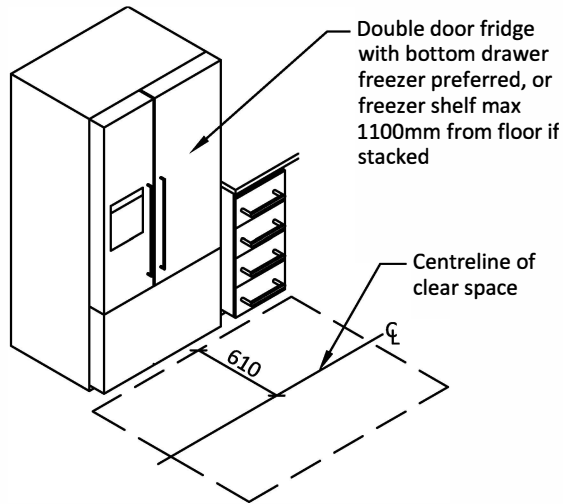

Figure 4.3.9 (g) - Fridge/Freezer

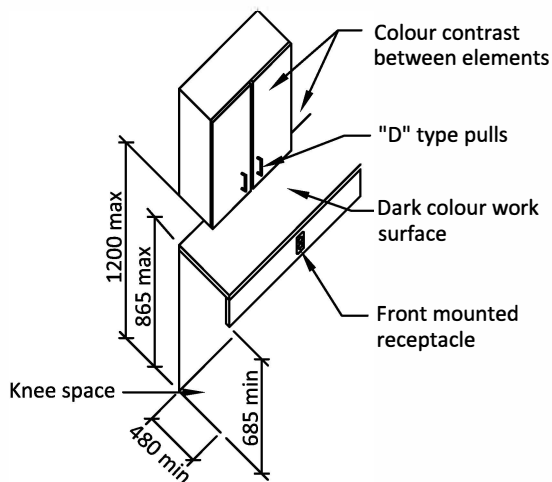

Figure 4.3.9 (h) - Storage Elements

4.3.10 Landscaping Materials and Planting

- 1) **Accessible** plant beds shall be:
 - a) Raised a minimum of 460 mm and a maximum of 865 mm above the adjacent floor or ground surface, and
 - b) Located on a solid surface adjacent to an **accessible route** complying with **Section 4.1.3 Accessible Routes, Paths and Corridors**.
- 2) The edges of planting beds located immediately adjacent to pedestrian **walks** shall incorporate clearly defined, **cane-detectable** curbs at least 100 mm high.
- 3) Where variations in grading immediately adjacent to pedestrian **walks** are potentially hazardous (particularly to persons who are blind or partially sighted), the hazardous edges of the **walk** shall incorporate clearly defined, **cane-detectable** curbs at least 100 mm high.
- 4) Shrubs with thorns and sharp edges shall be planted at least 920 mm away from **accessible** pathways and seating areas.
- 5) Plants that drop large seeds pods shall not overhang or be positioned near **accessible** paths or walkways.
- 6) Permanent guy wires shall not be used in any area which is intended for use by the general public, clients, customers or employees, unless the guy wires are protected by a **cane-detectable** barrier. Temporary guy wires, such as those used when planting new trees, shall be clearly identified using strong **colour contrast**.
- 7) Tree **guards** shall conform to **Sections 4.1.2 Protruding and Overhead Objects** and **4.1.3 Accessible Routes, Paths and Corridors**.
- 8) Overhanging branches of trees or shrubs over walkways or paths shall not reduce the available headroom at any part of the walkway or path to less than 2500 mm.

4.3.11 Benches

- 1) All benches and seating areas shall be **accessible** to all persons.
- 2) Benches shall:
 - a) Be adjacent to an **accessible route** complying with Section 4.1.3 **Accessible Routes, Paths and Corridors**,
 - b) Be stable,
 - c) Have a seat height between 430 mm and 485 mm from the ground – **Figure 4.3.11 (a)**,
 - d) Have a seat depth of at least 444 mm to 610 mm,
 - e) Have arm and back rests. Arm rests to be removable for transfer purposes from either side of the bench,
 - f) Be **colour contrasted** to their background,
 - g) Remain stable when a horizontal or vertical load of 1.112 kN is applied to any point on the seat, fastener, mounting device, or supporting structure.
 - h) Where installed in wet locations, the surface of the seat shall be slip-resistant and shall not accumulate water,
 - i) Have an adjacent level, firm ground surface at least 920 mm x 1370, located at least 300 mm back from the **accessible route**. It is preferred that this adjacent surface be **colour** and texture **contrasted** to the **accessible routes** – **Figure 4.3.11 (b)**.
- 3) Change benches shall:
 - a) Be located on an **accessible route**,
 - b) Have an adjacent clear floor area of at least 900 mm wide by the length of the bench,
 - c) Be at least 760 mm wide x 1830 mm long,
 - d) Have a top surface between 480 mm and 520 mm from the floor,
 - e) Be free of sharp edges or corners, and have no abrasive materials on surfaces,
 - f) Be designed to support a weight of at least 250 kg, and
 - g) Have a horizontal grab bar that
 - i) Complies with **Section 4.2.10 Grab Bars**,
 - ii) Is centered on the long dimension of the bench,
 - iii) Is at least 1200 mm long, and
 - iv) Is mounted between 750 mm and 850 mm from the floor.

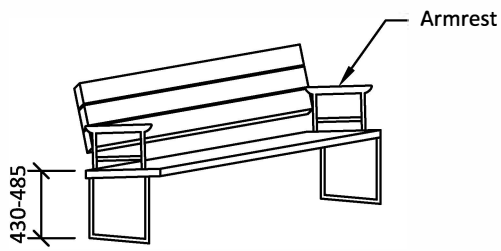

Figure 4.3.11 (a) - Bench Seating

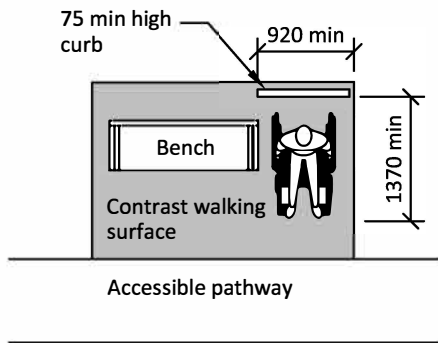

Figure 4.3.11 (b) - Rest Area

4.3.12 Waiting and Queuing Areas

- 1) Waiting and queuing areas, wherever possible, shall:
 - a) Have barriers spaced a minimum of 1060 mm, and
 - b) Be laid out in a logical, parallel, manner.
- 2) Barriers at queuing areas, provided to streamline people movement, shall be firmly mounted to the floor, and should have rigid rails to provide support for waiting persons.
- 3) Where floor slots or pockets are included to receive temporary or occasional supports, such slots or pockets shall be level with the floor finish and have an integral cover, so as not to cause a tripping hazard.
- 4) Permanent queuing areas shall incorporate clearly defined floor patterns, colours and textures complying with **Section 5.3 Texture and Colour**, as an aid to persons who are blind or partially sighted.
- 5) There shall be a pronounced colour and texture contrast between bars or solid barriers used to define queuing areas and the surrounding environment.

4.4 Systems and Controls

4.4.1 Controls and Operating Mechanisms

- 1) Controls and operating mechanisms generally used by staff or public (e.g., light switches and dispenser controls) shall comply with this section.
- 2) A clear, level floor area at least 800 mm x 1370 mm shall be provided at controls and operating mechanisms, such as dispensers and receptacles.
- 3) The **operable portions** of controls and operating mechanisms such as electrical switches, thermostats and intercom switches, shall be located between 900 mm and 1200 mm from the floor – **Figure 4.4.1 (a)**.

Exception: Elevators and power door operator controls. Refer to **Sections 4.1.8 Doors** and **4.1.13 Elevators**.

- 4) Controls or operating mechanisms shall:
 - a) Be located no closer than 700 mm from an inside corner, for side-access,
 - b) Be located no closer than 400 mm from an inside corner, for front-access.
- 5) Electrical outlets and other types of devices shall be located no lower than 400 mm – **Figure 4.4.1 (a)**.

Exception: Where electrical outlets are provided as components of systems furniture, these devices need not comply with this section provided they are installed in addition to electrical outlets required by the Authority having Jurisdiction.

- 6) Faucets and other controls shall be hand-operated or electronically controlled.
- 7) Hand-operated controls and mechanisms shall be operable:
 - a) With one hand, without tight grasping, pinching, or twisting of the wrist, and
 - b) With a force of less than 22kN (5 lbs.).
 - c) Control settings shall provide **tactile** and/or auditory information, indicating function and position of controls.
- 8) Information on visual displays shall:
 - a) Be supplemented by **tactile** and/or auditory information,
 - b) Be **colour contrasted**, and
 - c) Be located on a glare-free surface.
- 9) Operating mechanisms shall be capable of being illuminated to at least a level of 100 lux.
- 10) If an operating control has its own illumination or is backlit, and reading of the surface is not required for operation, an internal or background illumination level of 50 to 100 lux may be used.
- 11) **Colour contrast** shall be incorporated into controls and operating mechanisms to differentiate them from the surrounding environment.

- 12) Dispensers with visual markings shall also incorporate **tactile** lettering and pictograms, as well as Grade 1 **Braille**.

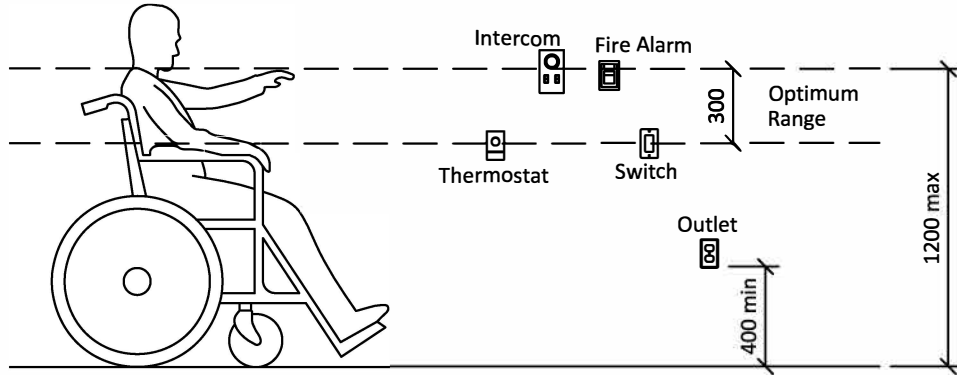

Figure 4.4.1 (a) - Reach Range for Accessible Controls

4.4.2 Emergency Exits, Fire Evacuation and Areas of Rescue Assistance

- 1) In **facilities**, or portions of **facilities**, required to be **accessible**, **accessible means of egress** shall be provided in the same number as required for exits by the National Building Code of Canada.
- 2) Where required exits from a floor level are not **accessible**, areas of rescue assistance shall be provided on the floor level in a number equal to that of the required exits.
- 3) Every occupiable level in non-residential occupancies above or below the first **storey** that is **accessible**, shall:
 - a) Be served by an elevator that has protection features, as specified in the National Building Code of Canada, or
 - b) Be divided into at least two zones by fire separations, as specified in the National Building Code of Canada.
- 4) Where emergency warning systems are provided, they shall include both audible alarms and visual alarms. Visual alarms shall comply with **Section 6.3 Visual Alarms**.
- 5) **Accessible means of egress** shall comply with **Section 4.1.3 Accessible Routes, Paths and Corridors**.
- 6) Signage identifying **accessible means of egress** shall comply with **Section 5.6 Signage**.
- 7) **Areas of rescue assistance** shall:
 - a) Be provided where there is an inaccessible exit,
 - b) Not be required in a facility supplied by a supervised automatic sprinkler system,
 - c) Be located on an **accessible route** complying with **Section 4.1.3 Accessible Routes, Paths and Corridors**,
 - d) Have a door in compliance with **Section 4.1.8 Doors**,
 - e) Incorporate the number of rescue **spaces** in accordance with **Table 4.4.2**.

| Occupant Load of Floor Area Served by the Area of Rescue Assistance | Minimum Number of Rescue Spaces |
|---|--|
| 1 to 400 | 2 |
| Over 400 | 3 plus 1 for each additional increment of 200 persons in excess of 400 persons |

Table 4.4.2 Area of Rescue Assistance

4.0 PHYSICAL ACCESSIBILITY

- f) Be of a size that allows a minimum **clear floor space** of 850 mm x 1370 mm per non-ambulatory occupant – **Figure 4.4.2 (a)**,
- g) Be separated from the floor area by a fire separation having a fire-resistance rating at least equal to that required for an exit,
- h) Be served by an exit or fire fighter elevator,
- i) Be designated as an **area of rescue assistance** for persons with disabilities on the **facility** plans and in the **facility**,
- j) Be smoke protected in **facilities** of more than three **storeys**,
- k) Incorporate a two way voice communication system for use between each **area of rescue assistance** and the central alarm and control **facility**,
- l) Be identified with directional **signage** complying with applicable provisions of **Section 5.6 Signage**, stating “**Area of Rescue Assistance**” and incorporate the international symbol for accessibility for disabled persons,
- m) Be identified on all publicly displayed floor evacuation plans,
- n) Be identified on floor evacuation plans that are available in alternate formats, and
- o) Be designated in evacuation procedure documents.

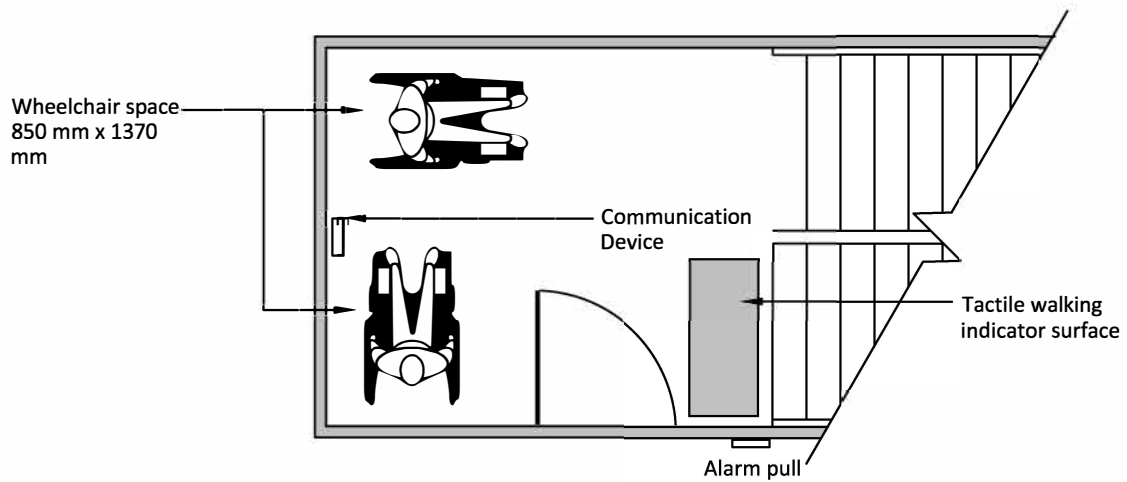

Figure 4.4.2 (a) - Area of Rescue Assistance

4.4.3 Card Access, Safety and Security Systems

- 1) Where signals intended for the public to indicate the operation of a **building** security system are provided, they shall consist of both audible alarms and visual signals.
- 2) Adequate lighting shall be provided continuously along public walkways, steps and **ramps** that are actively used at all times of year and/or where staff and public parking is provided.
- 3) Where public telephones are installed, an **accessible** public telephone complying with **Section 4.3.2 Public Telephones** shall be located at, or close to an **accessible entrance**, for the use of persons requiring assistance.
- 4) Where universal washrooms complying with **Section 4.2.7 Universal Washrooms** are provided in larger public **facilities**, such as recreation **facilities**, the washroom shall incorporate an emergency call system linked to a central location (e.g. office or switchboard).
- 5) Card-entry systems shall:
 - a) Be wall-mounted, no higher than 1060 mm above the floor or ground, adjacent to the door and free of the door swing,
 - b) Be located no closer than 700 mm from an inside corner, for side-access to the card-entry system,
 - c) Be located no closer than 400 mm from an inside corner, for front-access to the card-entry system,
 - d) Be **colour contrasted** from the surface on which they are mounted,
 - e) Provide both audible (beep) and/or verbal prompt (welcome) and visual (light) signals to indicate that access has been granted,
 - f) Where a card entry system is used that incorporates a card-slot, the card-slot shall have bevelled edges,
 - g) Incorporate a card-slot that is illuminated or **colour contrasted** from the mounting plate,
 - h) Include **tactile** graphic symbols on the surrounding surface that represents the card and its orientation for insertion, and
 - i) Use cards that incorporate a distinctive colour, texture or raised graphic/lettering on one side.
- 6) Encoded-entry/exit systems, such as keypads, shall:
 - a) Be wall-mounted, no higher than 1060 mm above the floor or ground, adjacent to the door and free for the door swing, and
 - b) Incorporate buttons that:
 - i) are raised,
 - ii) are mounted on a clearly differentiated coloured background, and
 - iii) include raised numerals or letters in a constant array, including Grade 1 **Braille**.
- 7) Intercom entry systems shall:
 - a) Comply with **Section 4.4.1 Controls and Operating Mechanisms**,
 - b) Provide both visual and verbal features to provide access for persons with vision, hearing or speech disabilities, and

- c) Provide both audible (beep) and visual (light) signals to indicate that access has been granted.

5.0 VISUAL ACCESSIBILITY

5.1 Glare and Light Sources

- 1) Systems used to control glare and excessive reflected light shall comply with this section.
- 2) Extensive high-gloss floor finishes are not acceptable but high-gloss materials may be incorporated into floor finish details, as long as they do not result in large reflective surfaces and/or slip hazards.
- 3) Monolithic floor surfaces, such as stone, granite, marble or terrazzo, shall have a matte or honed finish, to minimize reflected glare.
- 4) Horizontal surfaces shall be of matte or satin finish to reduce glare.
- 5) Finishes such as paint, vinyl wall coverings, stone, marble, wood, metals, plastic laminate, etc., used on vertical surfaces, such as walls and columns, shall have matte or satin finishes.
- 6) Extensive high-gloss wall finishes are not acceptable, but high-gloss materials may be incorporated into wall finish details, as long as they do not result in large reflective surfaces.
- 7) Curtains, blinds or other sun-screening systems shall be provided at windows and other places where direct sunlight can adversely affect the level of lighting and/or reflected glare.
- 8) Light fixtures shall be selected with diffusers, lenses or recessed light sources, so that minimal glare is created.
- 9) Surface mounted LED ceiling fixtures mounted below 2440 mm shall:
 - a) Have darkened sides,
 - b) Be positioned perpendicular to the dominant direction of travel, and
 - c) Create an indirect light (e.g. valance type lighting).
- 10) Supplementary lighting shall be used to enhance special features and key orientation **elements** provided they only have upward or downward components.

5.2 Lighting

- 1) Exterior lighting shall:
 - a) Be in compliance with the “Illuminating Engineering Society of North America Standards” in all public thoroughfares, and at all pedestrian routes, to provide safe access for persons with disabilities from sidewalks, bus stops and parking areas to nearby **facilities** and amenities.
 - b) Have a minimum 100 lux consistently over the **entrance** area, measured at the ground.
 - c) Have a minimum 30 lux consistently over frequently used pedestrian routes, including walkways, paths, stairs and **ramps**, measured at the ground.
 - d) Have a minimum 30 lux consistently over frequently used **accessible** parking **spaces** and limited mobility **space**, measured at the ground.
 - e) Be bright enough to clearly define treads, risers and nosings of frequently used steps and stairs.
 - f) Provide a good colour spectrum.
 - g) Be evenly distributed to minimize cast shadows.
 - h) Be provided to highlight key **signage** and orientation landmarks.
 - i) Be located at a height to allow for normal snow removal.
 - j) Lighting fixtures shall comply with the relevant parts of **Sections 4.1.2 Protruding and Overhead Objects**.
- 2) Interior lighting shall:
 - a) Be selected to minimize direct or indirect glare on nearby reflective surfaces.
 - b) Provide as full a spectrum of light as possible, as an aid to edge and colour definition.
 - c) Be configured to create an even distribution at floor level and to minimize pools of light and areas of shadow.
 - d) Be evenly distributed at the leading edge of stairs, steps, **ramps** or escalators to minimize tripping hazards.
 - e) Be consistent in elevator lobbies and elevator cabs, to minimize tripping hazards, and in no case shall be less than 200 lux.
 - f) Be evenly distributed in washrooms and dressing rooms and no less than 200 lux.
 - g) Be evenly distributed in office areas and no less than 300 lux.
 - h) Be at least 100 lux, generally at the walking surface, and in no place less than 50 lux for emergency lighting over stairs and **ramps**, in an exit or path of travel.
 - i) Be no less than 200 lux at the working surface over directional or informational **signage**, or highlighting other orientation features, at public telephones, information or service counters, and card or keypad security systems.
 - j) Be evenly distributed, and capable of being adjusted (e.g., dimmers) in meeting rooms and **assembly areas**.

- k) Be capable of being enhanced, even when other lighting is dimmed, at lecterns, podiums/platforms or other speaker locations, to permit ease of lip-reading and/or viewing of the hand actions of a nearby signer for persons who are deaf.

5.3 Texture and Colour

- 1) Colour schemes shall incorporate a pronounced **colour contrast**, to differentiate boundaries of objects, distinguish objects from their background, and to generally enhance spatial orientation.
- 2) Signs shall incorporate pronounced glare-free **colour contrast**. A minimum colour/brightness contrast of 70% light reflectance is required. For signs, the most visible colours are white or yellow on a black, charcoal or other dark background, such as brown, dark blue, dark green or purple. Black lettering on white is also acceptable, although less readable than the reverse. Unacceptable background colours are light grey and pastel colours. Red lettering on a black background is also unacceptable.

Note: Research indicates that signs are more legible for persons with low vision when characters contrast with their background by at least 70%. Contrast in percent shall be determined by: $\text{Contrast} = [(B1-B2)/B1] \times 100$, where B1=light reflectance value (LVR) of the lighter area and B2 = light reflectance value (LVR) of the darker area.

Any application both white and black are never absolute; thus, B1 never equals 100 and B2 is always greater than 0.

The greatest readability is usually achieved through the use of light coloured characters or symbols on a dark background.

- 3) **Colour contrast** shall be used as a safety measure to define edges or boundaries of objects (e.g., stair nosings, doors, **handrails**, etc.). Colour or tone shall be used to visually define the boundaries of a room (i.e., where the wall meets the floor). Baseboards in monochromatic environments shall be highly contrasting with the wall and floor colours, to provide boundary definition.
- 4) Colour shall be used consistently to visually identify distinctive objects (e.g., exit doors).
- 5) Either bright colours or a highly contrasting tone shall be used to assist with **wayfinding**. (e.g. If used as part of a **signage** band located on walls at eye level, this band is easier to follow than monolithic wall colouring, and can be the visual cue for other essential signs.)
- 6) End walls or return walls in long corridors shall be visually defined using highly **contrasting colours** or tone to enhance a change of direction or the end of the space.
- 7) **Tactile walking indicator surfaces** shall be used to define potential hazards. Refer to **Section 5.7 Tactile Walking Indicator Surfaces**. Suitable textures include:
 - a) 10 mm deep saw-cut concrete regular grooves, positioned no more than 100 mm apart, commencing no closer than 100 mm from the curb,

- grooves should be at right angles to the path of travel for exterior textures, and
- b) Raised domes, dots or squares, deeply grooved concrete, terrazzo or other stone-like materials, with closely centered grooves at right angles to the path of travel, or applied carborundum or other non-slip strips for interior textures.
- 8) All textured surfaces used as **detectable warning** devices shall be **cane-detectable** and clearly differentiated from the surrounding paving surfaces.
 - 9) Supplementary textural cues shall also be provided (e.g., by using different floor textures or materials, in major and minor routes).
 - 10) Clearly defined boundaries of materials like carpeting or floor tiles shall enhance **wayfinding** by defining such locations as the junction between walls and floors, doorway recesses and corridor intersections.
 - 11) Throughout any one **site**, the same texture shall be used to identify the same type of hazard.

5.4 Materials and Finishes

- 1) Suitable sidewalk paving surfaces include macadam, concrete, compacted gravel screenings, interlocking brick and patio stones.
- 2) Such materials used in walkways shall:
 - a) Have joints that are no greater than 6 mm wide, with variations in level of no more than 3 mm, and
 - b) Be sloped for easy drainage.
- 3) Gratings and grills shall:
 - a) Be located to one side of the pedestrian walkways, or
 - b) Have bars located perpendicular to the dominant path of travel, and
 - c) Have openings no greater than 13 mm.
- 4) Steps shall be finished with a non-slip material and incorporate highly contrasting nosings.
- 5) **Ramps** surfaces shall be firm with a non-slip finish.
- 6) **Handrails** and **guards** shall be:
 - a) Continuous,
 - b) Made of a smooth material, and
 - c) Finished in a contrasting colour to the surrounding environment.
- 7) Carpet shall be of low-level loop construction, non-static fibre, directly glued to the subfloor.
- 8) Where hard, monolithic materials are selected, they shall be non-slip and non-glare, complying with **Section 5.1 Glare and Light Sources**.
- 9) Where floor tiles, bricks or pavers are used, joints should be no wider than 6 mm and should be flush.
- 10) Wall surfaces in corridors shall be non-abrasive from the floor level to a minimum of 2000 mm above the finished floor.

5.5 Information Systems

- 1) Information systems, such as display kiosks, video display terminals and interpretive/informational panels shall comply with this section.
- 2) Where information is provided by video display terminals the same information shall be provided in an alternative format, such as audio, **Braille** and large-text print. The minimum font size for large-text print shall be 16 point.
- 3) Videos provided at video display terminals to include American Sign Language (ASL) in video.
- 4) Information systems designed for direct access by the public, such as a touch-screen video display, shall have keyboard or keypads mounted at a height suitable for use by persons using wheelchairs or scooters as per **Section 4.4.1 Controls and Operating Mechanisms**.
- 5) Essential information shall be displayed in large text on a **colour contrasting** background and should also be available in other formats, such as audiotape or large-text print.
- 6) Push buttons or other controls for accessing public information systems shall:
 - a) Be clearly identifiable by colour and/or tone from the background colour,
 - b) Include raised numbers, numerals or symbols for easy identification by persons who are visually impaired, and
 - c) Have **tactile** identification comply with **Section 5.3 Texture and Colours**.
- 7) Exhibits that include important artefacts, labels and graphics, shall be placed 1000 - 1200 mm from the floor.
- 8) Labels and descriptive **signage** shall be inclined from horizontal for easier reading.
- 9) Inclined informational/interpretive panels that cannot be read from 750 mm away shall allow 660 mm of knee clearance from the ground and at least 480 mm depth. If displays are legible from 750 mm or further, less clearance is permitted to a minimum height of 220 mm for toe kick clearance – **Figure 5.5 (a)**.
- 10) No part of the sign shall encroach on the path of travel. If encroachment is unavoidable, **cane-detection** through colour and texture change shall be provided on the ground.
- 11) A minimum 1500 mm x 1500 mm **clear floor space** directly in front of the sign is required for its approach and use. The **clear floor space** must be of a hard surface material – **Figure 5.5 (b)**.

Note: Ensure Informational/Interpretive Panels do not have sharp edges

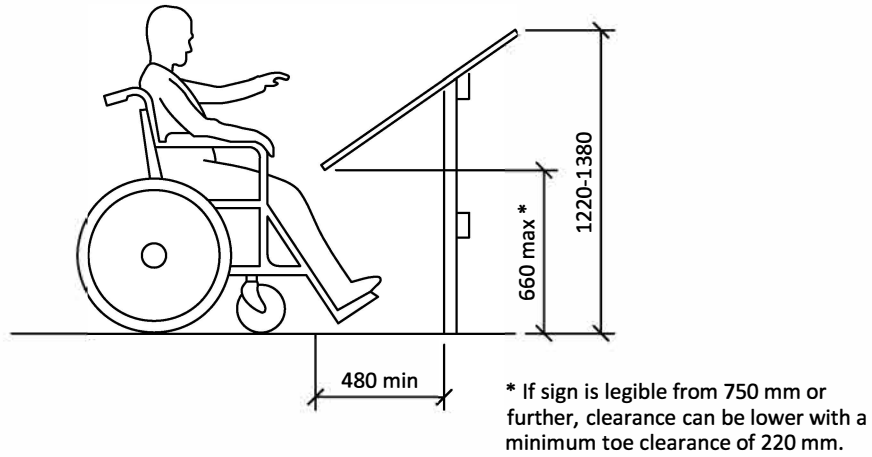

Figure 5.5 (a) - Informational/Interpretive Panel Clearances

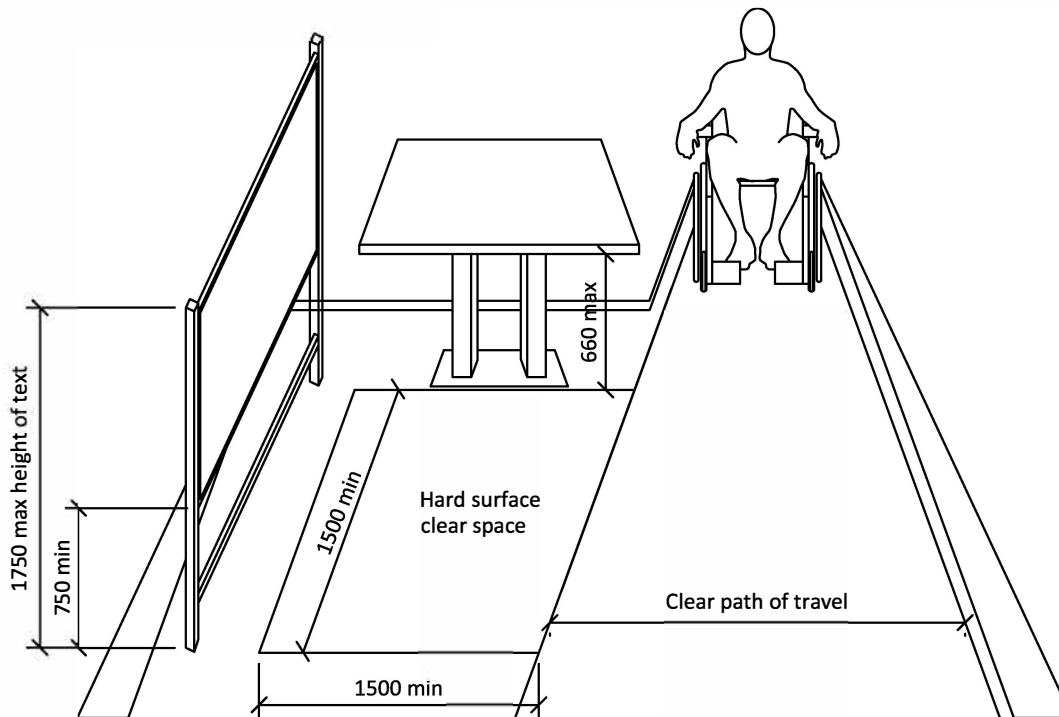

Figure 5.5 (b) - Informational/Interpretive Information Systems

5.6 Signage

- 1) Signs that designate permanent rooms or **spaces** shall be wall-mounted and include **tactile** and Grade 1 **Braille** characters and numbers.
- 2) **Tactile** markings shall also supplement the text of:
 - a) Regulatory signs, such as prohibition and mandatory signs,
 - b) Warning signs, such as caution and danger signs, and
 - c) Identification signs, such as rooms, titles, names and numbers.
- 3) Signs that provide direction to, or information about, functional **spaces**, shall comply with this section.

Exception: **Facility** directories, menus and all other signs that are temporary are not required to comply.

- 4) **Signage** shall:
 - a) Be of consistent shape, colour, position and height when locating a specific **facility** or service,
 - b) Be placed to avoid glare and/or shadows,
 - c) Be placed at direction-making points on a path of travel (e.g. exits, **entrances**, etc.),
 - d) Face the direction of travel,
 - e) Locate appropriate **accessible** parking,
 - f) Be visible from the street or public lane way when making a street address or **facility** name,
 - g) Be at a height which is visible even when snow is piled nearby,
- 5) **Elements** and **spaces** of **accessible facilities** that shall be identified by the International Symbol of Accessibility **Figure 5.6 (a)** are:
 - a) Parking **spaces**, designated as reserved for individuals with disabilities,
 - b) **Accessible** passenger loading zones,
 - c) **Accessible entrances** when included with **entrances** that are not **accessible** (inaccessible entrances shall have directional **signage** to indicate the route to the nearest **accessible entrance**),
 - d) **Accessible** toilet and bathing **facilities**, including single-use portable units, when not all are **accessible**,
 - e) **Accessible** telephones,
 - f) **Accessible** elevators and other elevating devices,
 - g) **Accessible means of egress**, and
 - h) **Areas of rescue assistance**.
- 6) Letters and numbers on signs shall:
 - a) Be sans serif fonts,
 - b) Have Arabic numbers,
 - c) Have a width-to-height ratio between 3:5 and 1:1, and
 - d) Have a stroke-width-to-height ratio between 1:5 and 1:10.

- e) Have a mixture of capital and lower case letters (e.g. St. John's) where applicable.
 - f) Not be mounted in a vertical position.
 - g) Move at a slow speed on scrolling signs.
- 7) Character height dimensions for viewing distance shall comply with **Table 5.6.**

| Minimum Character Height | Maximum Viewing Distance |
|--------------------------|--------------------------|
| 200 mm | 6000 mm |
| 150 mm | 4600 mm |
| 100 mm | 2500 mm |
| 75 mm | 2300 mm |
| 50 mm | 1500 mm |
| 25 mm | 750 mm |
| Less than 25 mm | Under 600 mm |

Table 5.6 Character Height on Interpretive & Wayfinding Signage

- 8) Characters, symbols and back-grounds of signs shall have an eggshell, matte or other glare-free finish.
- 9) Characters and symbols shall **colour contrast** with their background, either light characters on a dark background or dark characters on a light background, to a minimum of 70% with the background colour – **Figure 5.6 (b).**
- 10) Signs must be context sensitive (i.e. navy or dark grey on an exterior non-lit sign will disappear at night).
- 11) Where signs are required to be **tactile**, letters and numerals shall be – **Figure 5.6 (c):**
 - a) Raised at least 0.8 mm, not sharply edged,
 - b) Be between 16 mm and 50 mm high,
 - c) Be a sans serif font,
 - d) Be accompanied by Grade 1 uncontracted **Braille** in signs with limited amounts of text (up to 10 words), and on signs related to safety, and
 - e) Be in a contrasting colour of a minimum 70% with the background colour.
- 12) Pictograms shall be accompanied by an equivalent visual and **tactile** verbal description, placed directly below the pictogram. The border dimension of the pictogram shall be 150 mm minimum in height – **Figure 5.6 (d).**
- 13) Where permanent identification is provided for rooms and **spaces**, signs shall be installed on the wall adjacent to the latch side of the door, located with their centre line at a height between 1475 mm and 1525 mm. Where there is no wall **space** to the latch side of the door, including at double-leaf doors, signs shall be placed on the nearest adjacent wall, in a location that is easy to reach and touch – **Figure 5.6 (d).**

- 14) Signs shall be **colour contrasted** to the surface they are mounted upon. Framing the sign with a border matching the pictogram could enhance the **colour contrast**. The border creates a 3D effect when placed against a **colour contrasted** surface or wall.
- 15) Signs shall be placed minimum 2134 mm above the floor when mounted protruding from the wall.
- 16) The minimum level of illumination on signs shall be 200 lux.

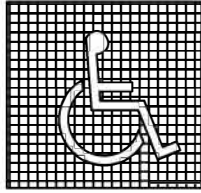

Grid for reference only

Figure 5.6 (a) - International Symbol of Access

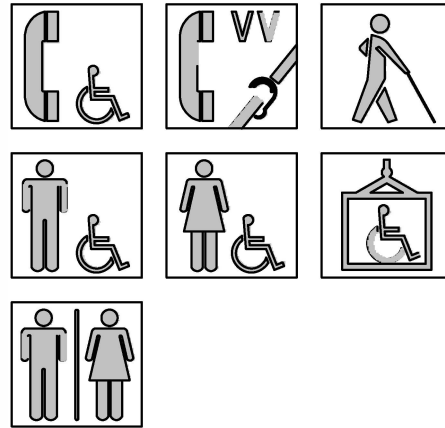

Note: Must incorporate equivalent verbal description

Figure 5.6 (d) - Pictograms

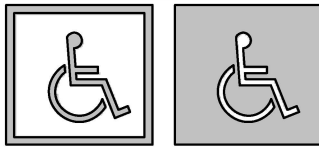

Figure 5.6 (b) - Colour Contrast on Signs

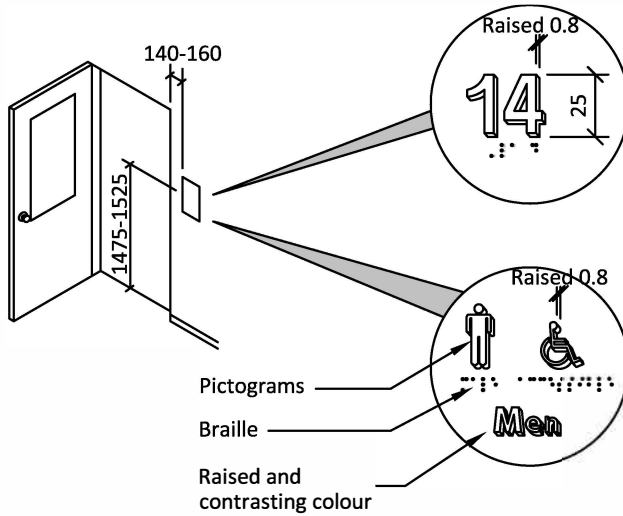

Figure 5.6 (c) - Tactile Lettering

5.7 Tactile Walking Indicator Surfaces

- 1) **Tactile walking indicator surfaces** at walkways, **curb ramps**, stairs and raised platforms shall comply with this section.
- 2) All textured surfaces used as **tactile walking indicator surfaces** shall be **cane-detectable** and clearly detectable by walking upon as being different from the surrounding surface. Refer to **Section 5.3 Texture and Colour**.
- 3) **Tactile walking indicator surfaces** shall contrast visually with adjoining surfaces by a minimum of 70% **colour contrast**, either light on dark or dark on light. Exterior **tactile walking indicator surfaces** installed in asphalt or concrete shall be yellow only.
- 4) **Tactile attention indicator surfaces** shall be composed of **truncated domes – Figure 5.7 (a)**.
 - a) With a height of 4.0 to 5.0 mm,
 - b) With a top diameter between 12 and 25 mm, and a base diameter 10 mm ± 1 greater than the top diameter.
 - c) Be organized in a regular, square grid pattern.
 - d) Have a centre to centre distance of adjacent domes complying with **Table 5.7**,

| Top Surface Diameter (mm) | Base Surface Diameter (mm ± 1 mm) | Centre to Centre Distance Between Domes (mm) |
|---------------------------|---------------------------------------|--|
| 12 | 22 | 42-61 |
| 15 | 25 | 45-63 |
| 18 | 28 | 48-65 |
| 20 | 30 | 50-68 |
| 25 | 35 | 55-70 |

Table 5.7.1 Dome Diameter and Spacing Combinations

- e) Be slip resistant when dry or wet, and
- f) Contrast visually with adjoining surfaces.
- 5) **Tactile attention indicator surfaces** shall – **Figure 5.7 (b)**:
 - a) Be provided at the top and bottom of the stairs and at landings,
 - i) Extend the full width of the stair for a depth between 600 mm and 650 mm commencing one tread depth back from the stair.
 - ii) Not more than 3 mm above or below the surrounding surface.
 - b) Be provided at the top and bottom of each **ramp**.
 - i) Extend the full width of the **ramp** for a depth between 600mm and 650 mm, and
 - ii) Not extend into the door swing area.

- c) Be provided at
 - i) an unprotected drop-off edge,
 - ii) changes in elevation greater than 250 mm,
 - iii) a slope steeper than a ratio of 1:3 (33%),
 - iv) at unprotected edges of a reflecting pool,
 - v) curb ramps and blended transitions, and
 - vi) an entry into a vehicular route or area where no curbs or other elements separate the vehicular route from the pedestrian route.
- 6) **Tactile direction indicator surfaces** shall be comprised of flat-topped, parallel, elongated bars, - **Figure 5.7 (e)**,
 - a) A height of 4.0 to 5.0 mm,
 - b) A top width between 17 and 30 mm, and a base width 10 ± 1 mm greater than the top width,
 - c) A centre-to-centre distance if adjacent bars to comply with **Table 5.7.2**,

| Top Width of Elongated Bars (mm) | Width (mm ± 1 mm) | Centre to Centre Distance Between Bars (mm) |
|----------------------------------|-----------------------|---|
| 17 | 27 | 57-78 |
| 20 | 30 | 60-80 |
| 25 | 35 | 65-83 |
| 30 | 40 | 70-85 |

Table 5.7.1 Dome Diameter and Spacing Combinations

- d) A top length not less than 270 mm and a base length 10 ± 1 mm greater than the top length, and
- e) Not more than a 30 mm space between the ends of in-line bars.
- 7) **Tactile direction indicator surfaces** shall
 - a) Be located in large open floor areas to facilitate **wayfinding** by indicating the primary route of travel.
 - b) Lead from the **entrance** to major destinations, such as an information kiosk, registration desk, stairway, elevator, or to store or service doors.
 - c) Where installed to define a route, - **Figures 5.7 (f)**,
 - i) be between 250 mm and 300 mm wide,
 - ii) have a clear space at least 600 mm on each side,
 - iii) have the elongated bars running in the direction of the route of travel, and
 - iv) have a 600 mm to 650 mm square **tactile attention indicator surface** installed at turns and decision points.
 - d) Where installed across an **accessible** path of travel as an indicator of a **facility** or diverging route,
 - i) be between 600 mm and 650 mm wide, and

- ii) have elongated bars running in the direction toward the **facility** or diverging route.
- e) Where there is a risk of water ponding, have the elongated bars interrupted by a drainage gap between 20 mm and 30 mm wide.
- 8) If a **walk** crosses or joins a **vehicular way** and the walking surfaces are not separated by curbs, railings or other **elements** between the pedestrian areas and vehicular areas, the boundary between the areas shall be defined by a continuous **tactile walking indicator surfaces**, for a depth between 600 mm and 650 mm wide – **Figures 5.7 (c) and 5.7 (d)**.

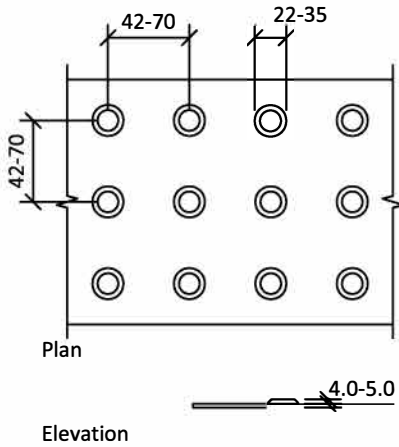

Figure 5.7 (a) - Truncated Dome Tactile Walking Indicator Surface

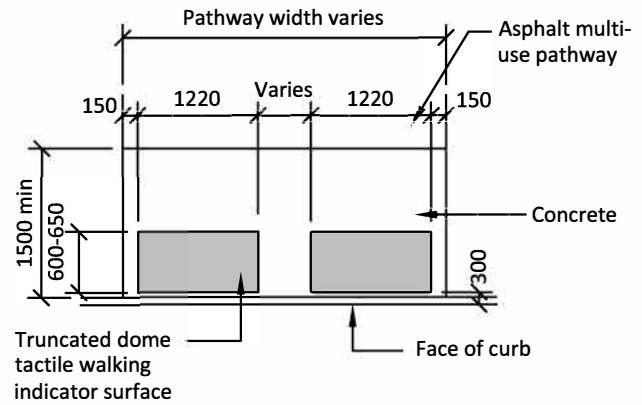

Figure 5.7 (c) - Tactile Walking Indicator Surface at Multi-Use Pathways

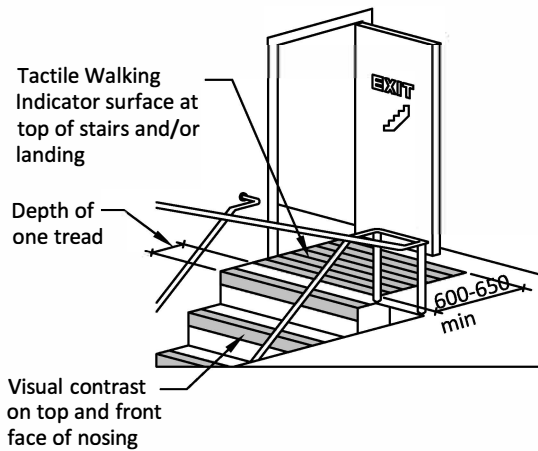

Figure 5.7 (b) - Tactile Walking Indicator Surfaces at Stairs

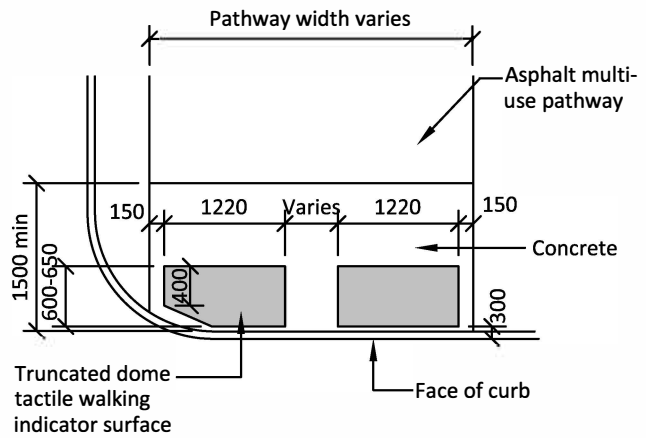

Figure 5.7 (d) - Tactile Walking Indicator Surface at Multi-Use Pathway Curb Junctions

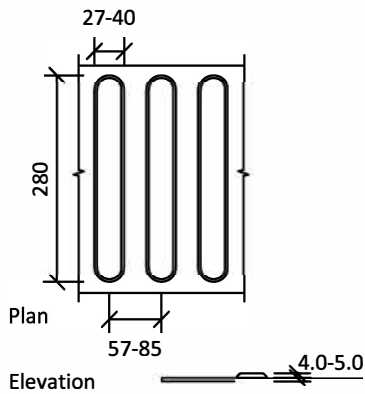

Figure 5.7 (e) - Elongated Bars, Tactile Direction Indicator Surface

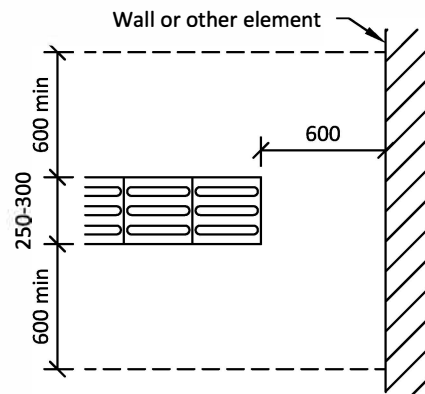

Figure 5.7 (f) - Elongated bars: start and termination

5.8 Windows, Glazed Screens and Sidelights

- 1) Windows, glazed screens, fully-glazed sidelights, fully glazed doors, and glazed panels in doors shall comply with this section.
- 2) Frameless glass doors and/or sidelights shall not be used.
- 3) Fully-glazed doors and sidelights at exterior entrances or vestibules, as well as fully-glazed interior doors, screens and sidelights shall be clearly identified with a horizontal row of decals, or a continuous strip.
 - a) The horizontal strip shall – **Figure 5.8 (a)**:
 - i) be a minimum 50 mm wide,
 - ii) be of highly **contrasting colour** with the surrounding environment,
 - iii) be mounted with its centre line between 1475 mm and 1525 mm from the floor or ground, and
 - iv) have a second horizontal strip or row of decals that has a centre line between 1170 mm and 1220 mm above the floor or ground.
 - b) Decals shall:
 - i) have a maximum distance of 150 mm from centre to centre,
 - ii) be either a 50 mm square, circle or special design, and
 - iii) be of highly **contrasting colour** with the surrounding environment.
 - c) Where etched or patterned glass is used, decals or a strip of highly **contrasting colour** shall still be provided.
- 4) Where frameless glass vision panels are used, exposed edges shall be identified with a vertical safety stripe applied to cap the ends of each exposed glass panel.
- 5) Where viewing windows or vision panels are provided:
 - a) The sill height shall be no more than 760 mm from the floor – **Figure 5.8 (b)**, and
 - b) Where horizontal mullions are incorporated, the mullions shall not be located between 1060 mm and 1220 mm from the floor.
- 6) In **facilities** with operable windows, window opening hardware shall:
 - a) Be mounted between 400 mm and 1200 mm from the floor,
 - b) Be operable using one hand, and
 - c) Not require fine finger control, tight grasping, pinching, or twisting of the wrist to operate.

5.0 VISUAL ACCESSIBILITY

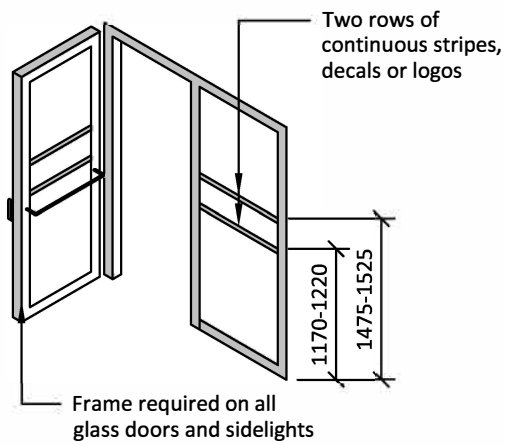

Figure 5.8 (a) - Fully Glazed Doors, Sidelights and Vision Panel Markings

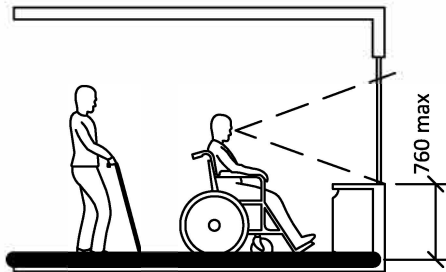

Figure 5.8 (b) - Window Sill Height

6.0 AUDIBLE ACCESSIBILITY**6.1 Acoustics**

- 1) Floor finishes, wall surfaces, ceilings and other large surfaces shall be selected so that noise is not excessively amplified.
- 2) At large **facilities**, the sound transmission and reflection characteristics of finish materials shall aurally differentiate major and secondary paths of travel at **accessible routes**.
- 3) Ceiling shapes shall be designed so that echoes do not occur, unless an alternate acoustical treatment is incorporated. (Note: domed shapes tend to distort sound.)
- 4) Public address and call systems shall be capable of being zoned to key areas, rather than blanketing all areas of a **facility** at all times. Refer to **Section 6.4 Public Address Systems**.
- 5) In meeting rooms and **assembly areas**, all unnecessary background noise (e.g., from fans or other mechanical equipment, air diffusers, etc.) shall be dampened and/or the room shall include adequate sound insulation.

6.2 Audible Signal

- 1) Audible signals, such as fire alarms and elevator arrival signals shall be loud and distinct, as to be heard over normal background noise.
- 2) Audible signals should be accompanied by visual alarms.
- 3) Public **buildings** or institutions providing services to seniors or individuals with disabilities should have a two-stage alarm system. One tone should indicate that there is a problem; a second tone should indicate when to evacuate the **building**.

6.3 Visual Alarms

- 1) Visual alarms shall be visible throughout the floor area or portion of it in which they are installed.
- 2) At a minimum, visual alarm appliances shall be provided in **facilities** in each of the following areas:
 - a) Rest rooms and any other general usage areas (e.g., meeting rooms),
 - b) Hallways,
 - c) Lobbies and any other areas for **common use**.
 - d) Exits and exit stairs on each floor,
 - e) Not less than one bedroom, sleeping area or dwelling unit and in not less than one for each 40 bedrooms, sleeping area or dwelling unit,
 - f) Each **accessible** room, where provided,
 - g) All public washrooms.
- 3) Visual alarm signal appliances shall be integrated into the **facility** alarm system. If single-station audible alarms are provided, then single-station visual alarms shall be provided.
- 4) A signal intended for the public to indicate the operation of a **building** security system that controls access to a **building** shall consist of an audible and visual signal.
- 5) In a retrofit situation where an alarm system is being upgraded, the alarm system shall include visual alarm signals.
- 6) Visual alarm signals shall have the following minimum photometric and location features:
 - a) The lamp shall be a Xenon strobe type or equivalent,
 - b) The colour shall be clear or nominal white (i.e. unfiltered or clear filtered white light),
 - c) The maximum pulse duration shall be two-tenths of one second (0.2 sec) with a maximum duty cycle of 40 percent. The pulse duration is defined as the time interval between initial and final points of 10% of maximum signal,
 - d) The intensity shall be a minimum of 75 candela,
 - e) The flash rate shall be a rate of 1 Hz,
 - f) The appliance shall be placed 2100 mm above the highest floor level within the space or 150 mm below the ceiling, whichever is lower,
 - g) In general, no place in any room or **space** required to have a visual signal appliance, shall be more than 15 meters from the signal (in the horizontal plane). In large rooms and **spaces** exceeding 30 meters across, without obstructions 2000 mm above the finished floor, such as auditoriums, devices may be placed around the perimeter, spaced a maximum of 30 meters apart, in lieu of suspending appliances from the ceiling,
 - h) No place in common corridors or hallways in which visual alarm signaling appliances are required shall be more than 15 meters from the signal, and
 - i) The alarms shall be synchronized to flash in unison.

6.4 Public Address Systems

- 1) To aid individuals with hearing or visual limitations, public address systems shall be easily heard above background noise without distortion or feedback.
- 2) Public address speakers shall:
 - a) Be mounted minimum 2134 mm above the floor,
 - b) Provide effective sound cover-age in required areas, such as corridors, assembly and meeting room areas, recreational and entertainment **facilities**, educational **facilities**, and
 - c) Be used in **common use** areas in institutional settings (i.e. washrooms).
- 3) Public address systems shall:
 - a) Be zoned so that information can be directed to key locations only, minimizing background noise in other areas,
 - b) Allow for background music in certain areas. The music shall not:
 - i) broadcast continuously, or
 - ii) broadcast throughout the entire **facility**.
 - c) Have the ability to shut off certain zones.
- 4) All-point call systems shall only be utilized for fire and emergency information.
- 5) Paging systems for staff and other key persons shall be discreet and low volume, and sound only at those devices or locations where such persons might expect to be located.
- 6) Other call systems, such as personal alarm or paging systems, shall be used with care according to the requirements of the user.

6.5 Assistive Listening Systems

- 1) **Assistive listening systems** should be permanently installed in **assembly areas** where:
 - a) Audible communication is integral to the use of the **space** (e.g. concrete theatres, meeting rooms, classrooms, auditoria, etc.),
 - b) They accommodate at least 50 persons,
 - c) The floor area of the **space** is greater than 100 sq. m.,
 - d) They have audio amplification systems, and
 - e) They have fixed seating.
- 2) For other **assembly areas**, a permanently installed listening system shall be provided. In smaller meeting **spaces**, supplementary wiring and electrical outlets necessary to support a portable listening system shall be provided. A portable listening device must be made available upon request.
- 3) The minimum number of receivers to be provided shall be equal to 4% of the total number of seats, but no less than two.
- 4) **Signage** complying with applicable provisions of **Section 5.6 Signage** and shall be installed to notify patrons of the availability of a listening system.
- 5) Acceptable types of **assistive listening systems** include:
 - a) Induction loops,
 - b) Infrared systems, and
 - c) FM radio frequency systems.
- 6) Where an induction loop system is provided:
 - a) Dimmer switches and other controls that incorporate transformer coils shall be located so as not to interfere with the audio induction loop, and
 - b) At least half the seating area shall be encompassed by the system.
- 7) Where infrared **assistive listening devices** are used, overhead lights shall be located so as not to cancel out the infrared signal at the receiver.
- 8) Where an FM loop system or other **assistive listening devices** are available in public **facilities** or meeting areas, portable headsets that are compatible with personal hearing aids shall be made available.
- 9) Where the listening system provided serves individual fixed seats:
 - a) Such seats shall be located within a 15 meter viewing distance of the stage or playing area, and
 - b) The seats shall have a complete view of the stage or playing area.
- 10) Background noise from mechanical systems shall be minimized.
- 11) Areas used for presentations and other public events, where listening to verbal communication is integral to the function of the **space**, shall incorporate one well-illuminated area for sign-language interpreting. Lighting control systems must allow the area to be independently controlled.

7.0 FACILITY SPECIFIC REQUIREMENTS

7.1 Meeting Rooms, Assembly Areas and Theatres

- 1) All meeting rooms, **assembly areas** and theatres should be **accessible**, regardless of varying disabilities, if intended to be used by the general public, tenants or visitors to a specific **building**.
- 2) A minimum of 1% of fixed seating but not less than one seat in **assembly areas**, meeting rooms and theatres shall:
 - a) Be an aisle seat with no arm rest, or with removable arm rests, and
 - b) Have a sign or marker which identifies the seat as **accessible**.
- 3) **Accessible** wheelchair or mobility aid seating locations shall be – **Figure 7.1 (a)**:
 - a) Distributed throughout the meeting room, **assembly area** or theatre to allow for various admission prices as well as various vantage points,
 - b) Located in a clear and level **space**. A removable seat may be provided for when the **accessible space** is not required.
 - c) A minimum of 915 mm x 1525 mm long where the wheelchair or scooter is required to enter the **space** from the side,
 - d) A minimum of 915 mm wide x 1370 mm long where the wheelchair or scooter is required to enter the **space** from the front or rear,
 - e) Arranged so a minimum of two designated wheelchair locations are positioned side by side,
 - f) Arranged so at least one fixed seat is located adjacent to each designated **accessible** location,
 - g) In conformance with **Table 7.1** when the seating capacity of the meeting room, **assembly area** or theatre exceeds 100, and

| Number of Fixed Seats in Seating Area | Minimum Number of Spaces required for Wheelchairs |
|---------------------------------------|---|
| Up to 50 | 2 |
| 51 to 150 | 4 |
| 151 to 300 | 5 |
| 301 to 500 | 6 |
| 501 to 5000 | 6 + 1 for each 150 |
| Over 5000 | 36 + 1 for each 200 |

Table 7.1 Wheelchair Viewing Locations

- h) Protected with guard rails which should not interfere with viewing.
- 4) **Handrails** complying with **Section 4.1.12 Handrails** shall be provided on the outer walls of auditorium seating areas.

7.0 FACILITY SPECIFIC REQUIREMENTS

- 5) All meeting rooms, **assembly areas** and theatres shall be accommodating to individuals with varying visual and hearing disabilities.
 - a) Major signs (e.g. room names) should be provide in both large print and **Braille** complying to **Section 5.6 Signage**.
 - b) Areas, where possible, shall be lit with indirect lighting, complying with **Section 5.2 Lighting**.
 - c) Display screens and other audio-visual equipment shall be positioned so as to allow for optimum visibility.
 - d) Where required, **assistive listening systems** shall be provided in all meeting rooms, **assembly areas** and theatres complying with **Section 6.5 Assistive Listening Systems**.
- 6) Meeting rooms, **assembly areas** and theatres shall have acoustics complying with **Section 6.1 Acoustics**.
- 7) All meeting rooms, **assembly areas** and theatres shall have **signage** complying with **Section 5.6 Signage**, indicating the intended use of the room.
- 8) Fixed seats designated for adaptable seating shall be:
 - a) Located adjoining a barrier-free path of travel without infringing on **egress** from any row of seating or any aisle requirements,
 - b) Equipped with a movable or removable armrest on the side of the seat adjoining the barrier-free path of travel, and
 - c) Situated, as part of the designated seating plan, to provide a choice of viewing location and a clear view of the event taking place.
 - d) Be high enough to facilitate transfer from a wheeled mobility device, while remaining high enough to afford good sight lines.

7.0 FACILITY SPECIFIC REQUIREMENTS

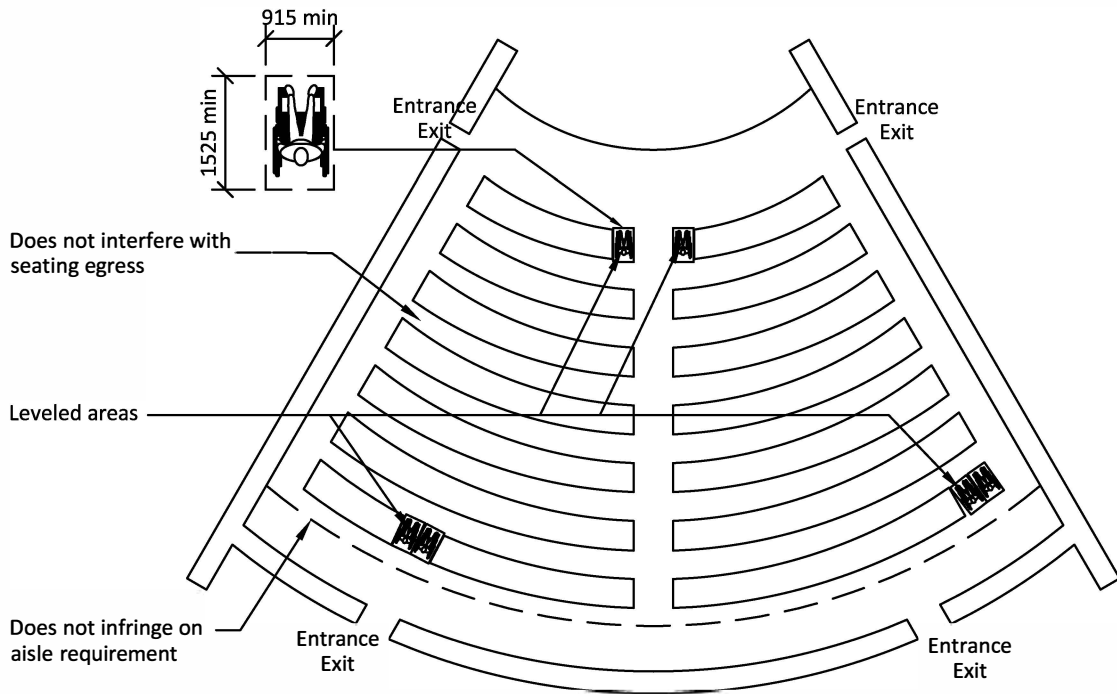

Figure 7.1 (a) - Theatre Viewing Locations

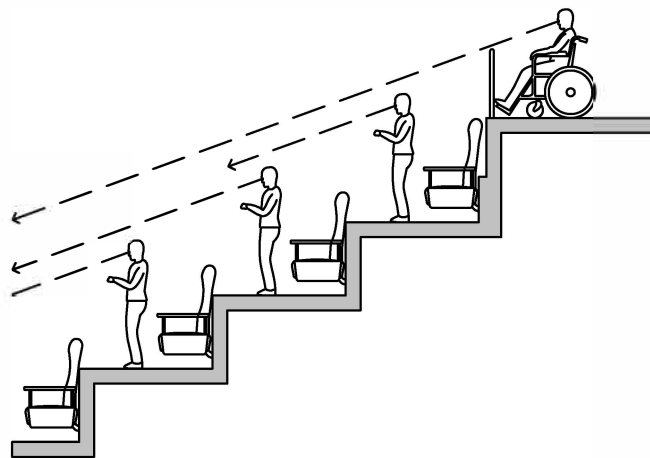

Figure 7.1 (b) - Sight Lines at Wheelchair Locations

7.2 Displays, Exhibition Areas, Galleries and Museums

- 1) All exhibits or displays should be displayed so individuals with various disabilities may access, enjoy and understand them.
- 2) All exhibits should be provided with audio including descriptive video for individuals who are blind or partially sighted.
- 3) Displays, exhibition areas, galleries and museums should be **accessible** to individuals who use mobility aids.
 - a) Aisles between exhibits shall be no less than 1065 mm wide,
 - b) Horizontal or inclined cases shall be no taller than 915 mm, and
 - c) Include a knee **space** of at least 700 mm.
- 4) **Tactile** exhibits should have information nearby which is printed in large text, **Braille**, or available in audiotape.
- 5) Audio exhibits should consider compatibility with hearing aids. Audio exhibits should have written information available nearby.
- 6) Lighting in displays, exhibition areas, galleries and museums shall comply with **Section 5.2 Lighting**. Consideration should also be given to:
 - a) Minimizing glare on display cases, and
 - b) Enhancing key locations for exhibit enjoyment.

7.3 Cafeterias

- 1) Where tables or counters are provided, at least 10%, but not less than one, shall be **accessible** and shall comply with **Section 4.3.5 Tables, Counters and Work Surfaces**. It is preferable to have all tables **accessible**.
- 2) At least one lane at each cashier area shall be **accessible** and comply with this section. It is preferable to have all lanes at all cashier areas **accessible**.
- 3) Where food or drink is served at counters exceeding 865 mm in height for use by customers seated on stools or standing at the counter, a portion of the main counter which is 1525 mm in length (minimum) shall be provided in compliance with **Section 4.3.3 Information, Reception and Service Counters**, or service shall be available at accessible tables within the same area.
- 4) All **accessible** tables shall be **accessible** by means of an **access aisle** at least 1100 mm clear between parallel edges of tables or between a wall and the table edges.
- 5) Food service lines shall have a minimum clear width of 1100 mm – **Figure 7.3 (a)**.
- 6) Tray slides shall be mounted no higher than 865 mm – **Figure 7.3 (b)**.
- 7) If self-service shelves are provided, at least 50% must be within the reach ranges specified in **Section 4.1.1 Space and Reach Requirements**. It is preferable to have all self-service shelves **accessible** – **Figure 7.3 (b)**.
- 8) Self-service shelves and dispensing devices for tableware, dishware, condiments, food and beverages shall be installed to comply with **Section 4.1.1 Space and Reach Requirements**.
- 9) Food behind glass doors shall have large print and **Braille** labels on the door.
- 10) Where menus are posted on a wall near the **entrance**, they shall be centred 1500 mm from the floor.
- 11) Cashier locations should feature at least one **access aisle**, which is a minimum of 1100 mm wide. It is preferable to have all aisles **accessible**.
- 12) **Spaces** for vending machines, beverage dispensers and other equipment shall comply with **Section 4.1.1 Space and Reach Requirements** and shall be located on an **accessible route** complying with **Section 4.1.3 Accessible Routes, Paths and Corridors**.
- 13) Barriers and/or turnstiles, where provided to control access, shall comply with **Section 4.1.9 Gates, Turnstiles and Openings**.
- 14) Queuing areas shall comply with **Section 4.3.12 Waiting and Queuing Areas**.

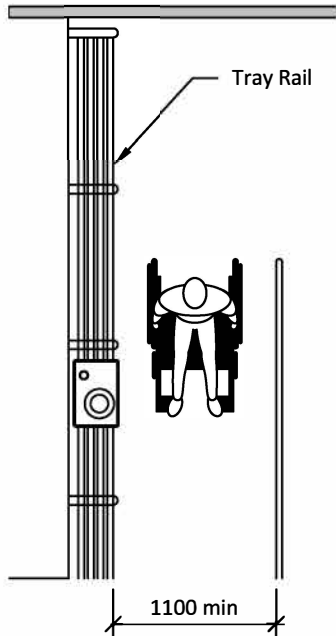

Figure 7.3 (a) - Cafeteria Aisle Width

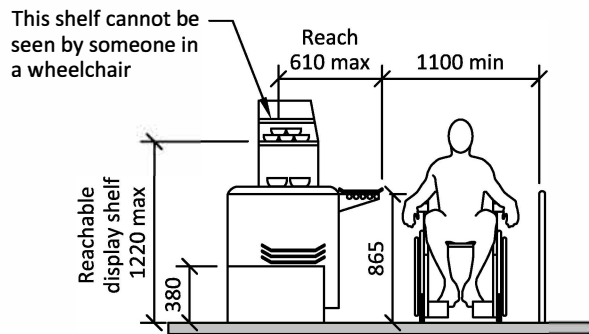

Figure 7.3 (b) - Cafeteria Counters

7.4 Libraries

- 1) Where seating, tables or study carrels are provided, at least 10% but no less than one shall be **accessible** and in compliance with this section. It is preferable to have all fixed seating, tables and study carrels **accessible**.
- 2) At least one location at each checkout area shall be **accessible** and comply with this section. It is preferable to have all locations at checkout areas **accessible**.
- 3) Where computer catalogues or workstations are provided, at least 50% but no less than one shall be **accessible** and shall comply with this section. It is preferable to have all computer catalogues and workstations **accessible**.
- 4) **Accessible** seating, tables and study carrels shall be located on an **accessible route** complying with **Section 4.1.3 Accessible Routes, Paths and Corridors**.
- 5) Clearances between seating, tables and study carrels shall comply with **Section 4.1.3 Accessible Routes, Paths and Corridors**.
- 6) Shelving in stacks areas shall be no higher than 1350 mm from the floor to the bottom of the highest shelf, with a minimum low reach of 400 mm to the lowest shelf – **Figure 7.4 (a)**.
- 7) **Accessible** study carrels shall incorporate:
 - a) Work surfaces and knee/toe clearance complying with **Section 4.1.1 Space and Reach Requirements**,
 - b) An electrical outlet, and
 - c) Lighting levels of at least 200 lux at the work surface.
- 8) Where provided, traffic control or book security gates shall comply with **Section 4.1.9 Gates, Turn-stiles and Openings**.
- 9) Minimum clear aisle **space** at stacks shall comply with **Section 4.1.1 Space and Reach Requirements**.
- 10) Aisle configurations shall incorporate a **clear floor space** allowing a person in a wheelchair to make a 180-degree turn – **Figure 7.4 (b)**.
- 11) Maximum reach heights at card catalogues shall comply with **Section 4.1.1 Space and Reach Requirements**.
- 12) Circulation service counters and information service counters shall comply with **Section 4.3.3 Information, Reception and Service Counters**.
- 13) Where provided, computer catalogue or computer workstation shall incorporate:
 - a) Knee and toe **space** below complying with **Sections 4.1.1 Space and Reach Requirements** and **4.3.5 Tables, Counters and Work Areas**.
 - b) A maximum work surface height of 865 mm, and
 - c) A maximum table depth of 915 mm.
- 14) A minimum of one movable chair shall be provided at every information service counter, computer catalogue or computer workstation.
- 15) Book drop slots shall:
 - a) Be located on an **accessible route** complying with **Section 4.1.3 Accessible Routes, Paths and Corridors**,

7.0 FACILITY SPECIFIC REQUIREMENTS

- b) Be located adjacent to a 2440 mm x 2440 mm level **clear floor space**.,
and
 - c) Have a slot that is operable using one hand, located between 860 mm and 900 mm above the floor.
- 16) Lighting at book stacks should preferably be mounted directly over the aisle **space** and provide a minimum of 200 lux at a nominal working height of 920 mm.
- 17) The acoustic quality shall be free of unnecessary background noise and should permit comprehension by persons with limited hearing.
- 18) Where CDs tapes, talking books, etc. are available as part of the library resource materials, or for loan purposes, a separate **space** shall be provided for auditing this material without disturbing other library users. An acceptable alternative would be to provide headphones for use.

7.0 FACILITY SPECIFIC REQUIREMENTS

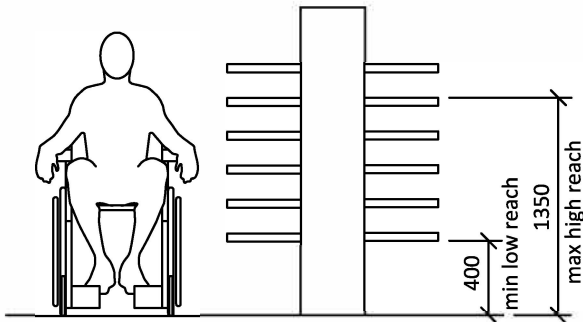

Figure 7.4 (a) - Reach Heights

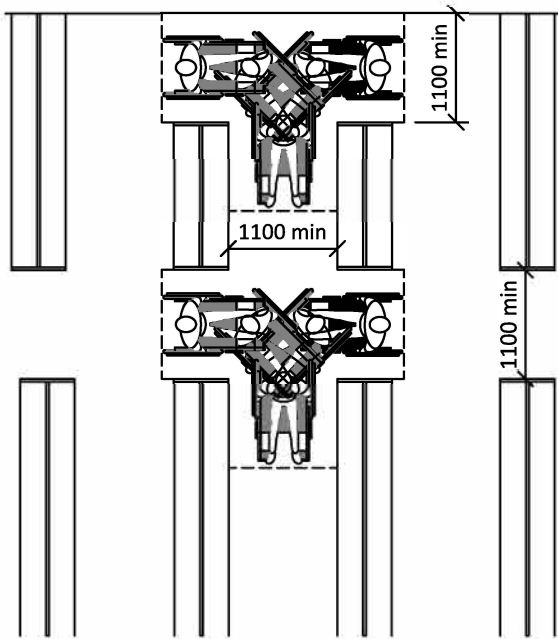

Figure 7.4 (b) - Aisle Width

7.5 Courts

- 1) In providing **entrances** complying to **Section 4.1.5 Entrances**, at least one restricted and secured **entrance** shall be **accessible**.
 - a) Secured **entrances** operated by security personnel need not be **accessible**.
- 2) Where security barriers restrict access, such as metal detectors, an **accessible route** shall be provided adjacent to barriers.
- 3) Where two-way communication devices are provided to gain access to a **facility**, the device shall provide both audible and visual signals.
- 4) Where provided, the following **elements** and **spaces** shall be on an **accessible route** complying with **Section 4.1.3 Accessible Route, Paths and Corridors**:
 - a) Spectator, press and other areas with a seating capacity of 25 or less shall have within its defined area a **clear floor space** complying with **Section 4.1.1 Space and Reach Requirements**.
 - b) Spectator, press and other areas with a seating capacity of greater than 25 seating provision shall be provided complying with **Section 7.1 Meeting Rooms, Assembly Areas and Theatres**.
 - c) Jury boxes and witness stands shall have within its defined area a **clear floor space** complying with **Section 4.1.1 Space and Reach Requirements**.
 - d) Judges' benches, clerk's stations, bailiffs' stations, court reporters' stations and litigants' and counsel stations shall comply with **Section 4.3.5 Tables, Counters and Work Surfaces**.

Exception:

In **alterations**, **accessible clear floor spaces** are not required to be located within the defined area of jury boxes or witness stands and may be located outside these spaces where a **ramp** or lift access poses a hazard by restricting or projecting into a required **means of egress**.

- 5) **Assistive listening systems** complying to **Section 6.5 Assistive Listening Systems** shall be permanently installed in each courtroom:
 - a) A minimum number of receivers shall be 4% of the room occupant load, but not less than two.
 - b) **Signage** indicating the availability of **assistive listening systems** shall be posted in a highly visible place.
- 6) Where provided in areas for jury assembly or deliberation, the following **elements** or **spaces** shall be on an **accessible route** complying with **Section 4.1.3 Accessible Routes, Paths and Corridors** and shall comply with the following provisions:
 - a) Refreshment areas, kitchenettes and fixed or built-in refreshment dispensers shall be **accessible** to persons with disabilities.

- b) Where provided, drinking fountains shall comply with **Section 4.3.1 Drinking Fountains.**

7.6 Gymnasiums

- 1) Gymnasiums, whether for educational or recreational purposes, shall be **accessible** to individuals with various disabilities.
- 2) The main floor, and/or exercise areas shall be fully **accessible**, including related:
 - a) Change areas,
 - b) Showers,
 - c) Washrooms, and
 - d) Locker areas.
- 3) **Accessible** dressing rooms, fittings, and locker rooms shall include:
 - a) A change bench that complies with **Section 4.3.11 Benches**,
 - b) An emergency call system with appropriate **signage**, which will activate an indicator light and an audible signal both inside and outside the room, to summon non-emergency customer service assistance, if needed,
 - c) An **accessible** clothing hook
 - i) at a height not more than 1200 mm from the floor, and
 - ii) protruding not more than 400 mm from the wall.
 - d) A full length mirror, and
 - e) Grab bars.
 - f) Detectable warning strips at the doors of change areas.
- 4) For an individual dressing room, fitting room or locker room, the door shall either swing out, or if it swings in, there shall be a **clear floor space** of at least 800 mm x 1370 mm beyond the door swing room inside the room. The **clear floor space** shall be positioned for parallel approach to the long side of the bench and have room for a 1930 mm diameter turning circle.
- 5) If the change bench is not affixed to a wall, back support shall be provided. Back support shall be at least 1100 mm in length and extend from a point 50 mm maximum above the seat to a point 450 mm minimum above the seat.
- 6) Bleachers or seating areas, whether temporary or permanent, shall:
 - a) Be on **accessible route**, complying with **Section 4.1.3 Accessible Routes, Paths and Corridors**,
 - b) Make provisions for wheelchairs, offering a variety of locations and views, and
 - c) Provide stairs conforming to all applicable codes:
 - i) with a 25 mm vertical and horizontal **colour contrasting** strip at the nosing,
 - ii) with **colour contrasting** and **tactile** clues to define the width of the stairs, and with sufficient illumination.
 - d) Wherever possible, provide additional **handrails** at centre aisles to assist persons using canes:
 - i) mounted in the middle of the aisle, and
 - ii) mounted so as to not obstruct sight lines.

7.0 FACILITY SPECIFIC REQUIREMENTS

- 7) Gymnasiums, in both the gymnasium area and the viewing area, shall have no obstacles which would hinder individuals with visual disabilities such as, but not limited to:
 - a) Unprotected floor slots,
 - b) Underside of bleacher areas,
 - c) Signs,
 - d) Brackets, and
 - e) Equipment protruding from wall as per **Section 4.1.2 Protruding Objects**.

8.0 ACKNOWLEDGEMENTS

The following documents were referenced while developing this universal design standard.

CSA B651-18
Accessible Design for the Built Environment

National Building Code of Canada, 2015

Government of Newfoundland and Labrador
Buildings Accessibility Act and Regulations

2010 Accessibility Design Standard
City of Winnipeg

2007 Facility Accessibility Design Standards
City of London

City of Toronto
Accessibility Design Guidelines

2006 Barrier-Free Design Guidelines
City of Hamilton